

# PDS-8x1 Series

## User Manual

Ver. 1.1.2

*Programmable Device Server with I/O Expansion Slot(s)*



### **WARRANTY**

All products manufactured by ICP DAS are warranted against defective materials for a period of one year from the date of delivery to the original purchaser.

### **WARNING**

ICP DAS assumes no liability for damages consequent to the use of this product. ICP DAS reserves the right to change this manual at any time without notice. The information furnished by ICP DAS is believed to be accurate and reliable. However, no responsibility is assumed by ICP DAS for its use, nor for any infringements of patents or other rights of third parties resulting from its use.

### **COPYRIGHT**

Copyright © 2014 by ICP DAS. All rights are reserved.

### **TRADEMARKS**

Names are used for identification purposes only and may be registered trademarks of their respective companies.

### **CONTACT US**

If you have any questions, please feel free to contact us via email at:

[service@icpdas.com](mailto:service@icpdas.com), [service.icpdas@gmail.com](mailto:service.icpdas@gmail.com)



### **SUPPORT**

This manual relates to the following modules:  
PDS-811 and PDS-821

# TABLE OF CONTENTS

**PACKING LIST..... 5**

**MORE INFORMATION ..... 5**

**1. INTRODUCTION ..... 6**

1.1 SELECTION GUIDE ..... 7

1.2 ETHERNET SOLUTIONS ..... 8

1.3 VxCOMM TECHNOLOGY ..... 9

1.4 WEB SERVER TECHNOLOGY ..... 11

**2. HARDWARE INFORMATION..... 12**

2.1 SPECIFICATIONS..... 12

2.2 FEATURES ..... 13

2.3 APPLICATIONS..... 13

2.4 APPEARANCE ..... 14

2.5 DIMENSIONS..... 16

2.6 PIN ASSIGNMENTS ..... 18

2.6.1 PDS-811 and PDS-821 ..... 18

2.6.2 I-8112iW..... 19

2.6.3 I-8114W..... 20

2.6.4 I-8114iW..... 21

2.6.5 I-8142iW..... 22

2.6.6 I-8144iW..... 23

2.7 WIRING NOTES FOR RS-232/485/422 INTERFACES ..... 24

2.7.1 RS-232 Wiring ..... 24

2.7.2 RS-422 Wiring..... 25

2.7.3 RS-485 Wiring..... 25

**3. SETTING UP THE PDS-8X1 CONTROLLER..... 27**

**4. WEB CONFIGURATION..... 36**

4.1 LOGGING IN TO THE PDS-8X1 WEB SERVER ..... 36

4.2 NETWORK SETTING ..... 38

4.2.1 IP Filter Setting..... 42

4.3 COM PORT SETTINGS ..... 45

4.3.1 Operation Mode: M0, M1 and M2..... 49

- 4.3.2 *Set Remote VCOM3 Connection* ..... 51
- 4.4 MISC. SETTINGS ..... 53
  - 4.4.1 *Disable the “Web Read Only” Function* ..... 54
  - 4.4.2 *Change Password* ..... 56
  - 4.4.3 *Restore to Factory Default Settings* ..... 57
- 5. TYPICAL APPLICATIONS ..... 59**
  - 5.1 VIRTUAL COM APPLICATION ..... 59
  - 5.2 ETHERNET I/O APPLICATIONS ..... 60
  - 5.3 PAIR-CONNECTION APPLICATIONS ..... 62
- 6. CONSOLE/TELNET COMMANDS LIST ..... 71**
  - 6.1 OPERATION FLOWCHART ..... 71
  - 6.2 COMPARISON SHEET (INIT, RUN AND CONSOLE MODES) ..... 72
  - 6.3 COMMAND LIST ..... 73
    - 6.3.1 *IPFILTER* ..... 74
    - 6.3.2 *IPCONF* ..... 76
    - 6.3.3 *SOCKET* ..... 77
    - 6.3.4 *COM* ..... 78
    - 6.3.5 *Broadcast* ..... 79
    - 6.3.6 *SystemTimeout* ..... 80
    - 6.3.7 *SocketTimeout* ..... 81
    - 6.3.8 *M* ..... 82
    - 6.3.9 *EchoCmdNo* ..... 83
    - 6.3.10 *EndChar* ..... 84
    - 6.3.11 *IP* ..... 85
    - 6.3.12 *MASK* ..... 85
    - 6.3.13 *GATEWAY* ..... 86
    - 6.3.14 *MAC* ..... 86
    - 6.3.15 *NAME* ..... 87
    - 6.3.16 *ALIAS* ..... 87
    - 6.3.17 *DHCP* ..... 88
    - 6.3.18 *UDP* ..... 89
    - 6.3.19 *VER* ..... 90
    - 6.3.20 *SAVE* ..... 90
    - 6.3.21 *LOAD* ..... 91
    - 6.3.22 *CONFIG* ..... 93
    - 6.3.23 *RESET* ..... 94
    - 6.3.24 *QUIT* ..... 94

<b>APPENDIX A: LINKING TO A DEVELOPMENT PC .....</b>	<b>95</b>
<b>APPENDIX B: GLOSSARY .....</b>	<b>100</b>
1. <b>ARP (ADDRESS RESOLUTION PROTOCOL) .....</b>	<b>100</b>
2. <b>CLIENTS AND SERVERS .....</b>	<b>100</b>
3. <b>ETHERNET .....</b>	<b>101</b>
4. <b>FIRMWARE .....</b>	<b>101</b>
5. <b>GATEWAY .....</b>	<b>101</b>
6. <b>ICMP (INTERNET CONTROL MESSAGE PROTOCOL) .....</b>	<b>101</b>
7. <b>INTERNET .....</b>	<b>101</b>
8. <b>IP (INTERNET PROTOCOL) ADDRESS .....</b>	<b>102</b>
9. <b>MAC (MEDIA ACCESS CONTROL) ADDRESS .....</b>	<b>102</b>
10. <b>PACKET .....</b>	<b>102</b>
11. <b>PING .....</b>	<b>102</b>
12. <b>RARP (REVERSE ADDRESS RESOLUTION PROTOCOL) .....</b>	<b>103</b>
13. <b>SOCKET .....</b>	<b>103</b>
14. <b>SUBNET MASK .....</b>	<b>103</b>
15. <b>TCP (TRANSMISSION CONTROL PROTOCOL) .....</b>	<b>103</b>
16. <b>TCP/IP .....</b>	<b>104</b>
17. <b>UDP (USER DATAGRAM PROTOCOL) .....</b>	<b>104</b>

# Packing List

The shipping package includes the following items:

- ☑ One PDS-811 or PDS-821 series hardware controller
- ☑ One software utility CD
- ☑ One download cable (CA-0910)
- ☑ One printed Quick Start Guide



PDS-811



PDS-821



Software CD



CA-0910

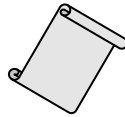

QuickStart



## Note:

If any of these items are missing or damaged, please contact the local distributor for more information. Save the shipping materials and cartons in case you need to ship the module in the future.

## More Information

### Documentation

CD:\NAPDOS\PDS\PDS-8x1\Document

<http://ftp.icpdas.com/pub/cd/8000cd/napdos/pds/pds-8x1/document/>

### Firmware

CD:\NAPDOS\PDS\PDS-8x1\VxComm\Server(PDS)

[http://ftp.icpdas.com/pub/cd/8000cd/napdos/pds/pds-8x1/vxcomm/server\(pds\)/](http://ftp.icpdas.com/pub/cd/8000cd/napdos/pds/pds-8x1/vxcomm/server(pds)/)

### Software

CD:\NAPDOS\PDS\PDS-8x1

<http://ftp.icpdas.com/pub/cd/8000cd/napdos/pds/pds-8x1/>

# 1. Introduction

The PDS-811 and PDS-821 programmable device servers (PDS) are compact, modular, intelligent, rugged, and are designed for networking RS-232 and RS-422/485 serial devices to an Ethernet network. The PDS-811 has one I/O expansion slot, while PDS-821 has two I/O expansion slots that can be used to attach various 2- or 4-port serial communication modules. Therefore, a maximum of 4 serial ports can be installed on the PDS-811 or a maximum of 8 serial ports can be installed on the PDS-821.

Note: There is no serial module built-in to the PDS-811 or PDS-821 by default.

The PDS-811 and PDS-821 controllers are equipped with a 2-port 10/100 Base-TX Ethernet Switch that can be used to connect two network segments. The Ethernet Switch processes and routes data on the data-link layer (layer 2) of the OSI model to create a different collision domain per switch port. Using a switch allows you to attain dedicated bandwidth on point-to-point connections with every computer, and therefore run in full duplex mode with no collisions. Furthermore, the built-in 2-port Ethernet Switch on the PDS-811/821 enables network wiring to be simplified by cascading your Ethernet devices.

The PDS-8x1 series contains a built-in operating system, the MiniOS7, which offers a stable and high performance environment that is similar to DOS. The MiniOS7 can boot up the PDS-8x1 series within just one second, with the added benefit of no virus problems and a small footprint. Furthermore, the PDS-8x1 series is designed for low power consumption, maintenance elimination (no hard disk and no fan), and is constructed from fire retardant materials (UL94-V0 level) with a robust case.

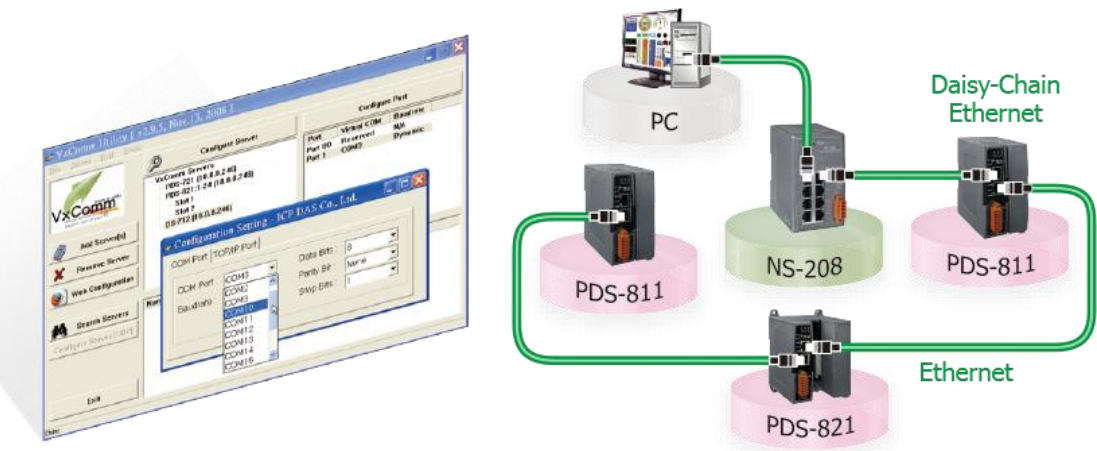

# 1.1 Selection Guide

➤ PDS-8x1 Series controllers Selection Guide

Model	PDS-811	PDS-821
Slots	1	2
CPU	80186 (80 MHz)	80186 (80 MHz)
RAM/Flash Disk	512 KB/512 KB	512 KB/512 KB
Ethernet	2-Port Ethernet Switch	2-Port Ethernet Switch
Operating System	MiniOS7	MiniOS7
Console Port	3-wire RS-232	3-wire RS-232
Serial Ports (Optional) Max.	4	8

➤ Optional Serial Modules Selection Guide

Model	I-8112iW	I-8114W	I-8114iW	I-8142iW	I-8144iW
Interface	9-wire RS-232	9-wire RS-232	5-wire RS-232	4-wire RS-422 2-wire RS-485	4-wire RS-422 2-wire RS-485
Ports	2	4	4	2	4
FIFO	128 Bytes	128 Bytes	128 Bytes	128 Bytes	128 Bytes
Isolation	3000 V	-	3000 V	3000 V	3000 V
Self-tuner	-	-	-	Yes	Yes
Connector	DB-9	DB-37	DB-37	Terminal Block	Terminal Block

Note:

2-wire RS-485: Data+, Data- with Self-Tuner inside

4-wire RS-422: TxD+, TxD-, RxD+, RxD-

3-wire RS-232: RxD, TxD, GND

5-wire RS-232: RxD, TxD, CTS, RTS, GND

9-wire RS-232: RxD, TxD, CTS, RTS, DSR, DTR, DCD, RI, GND

## 1.2 Ethernet Solutions

Nowadays, the Ethernet protocol has become the foremost standard for local area networks. Connectivity via the Internet is now common in many of the latest applications from home appliances, to vending machines, to testing equipment, to UPS, etc. An Ethernet network can link office automation and industrial control networks, access remote systems and share data and information between machines from multiple vendors, and also provides a cost-effective solution for industrial control networks.





### 1.3 VxComm Technology

In general, writing a TCP/IP program is more difficult than writing a COM Port program. Another issue is that perhaps the existing the COM Port communication system was built many years ago and is now outdated.

As a result, a new technology, VxComm was developed to virtualize the COM Ports of the PDS-8x1 controller to allow up to 256 COM Ports to be used on a central computer. The VxComm driver saves time when accessing serial devices through the Ethernet without the need for reprogramming the COM Port software on the PC.

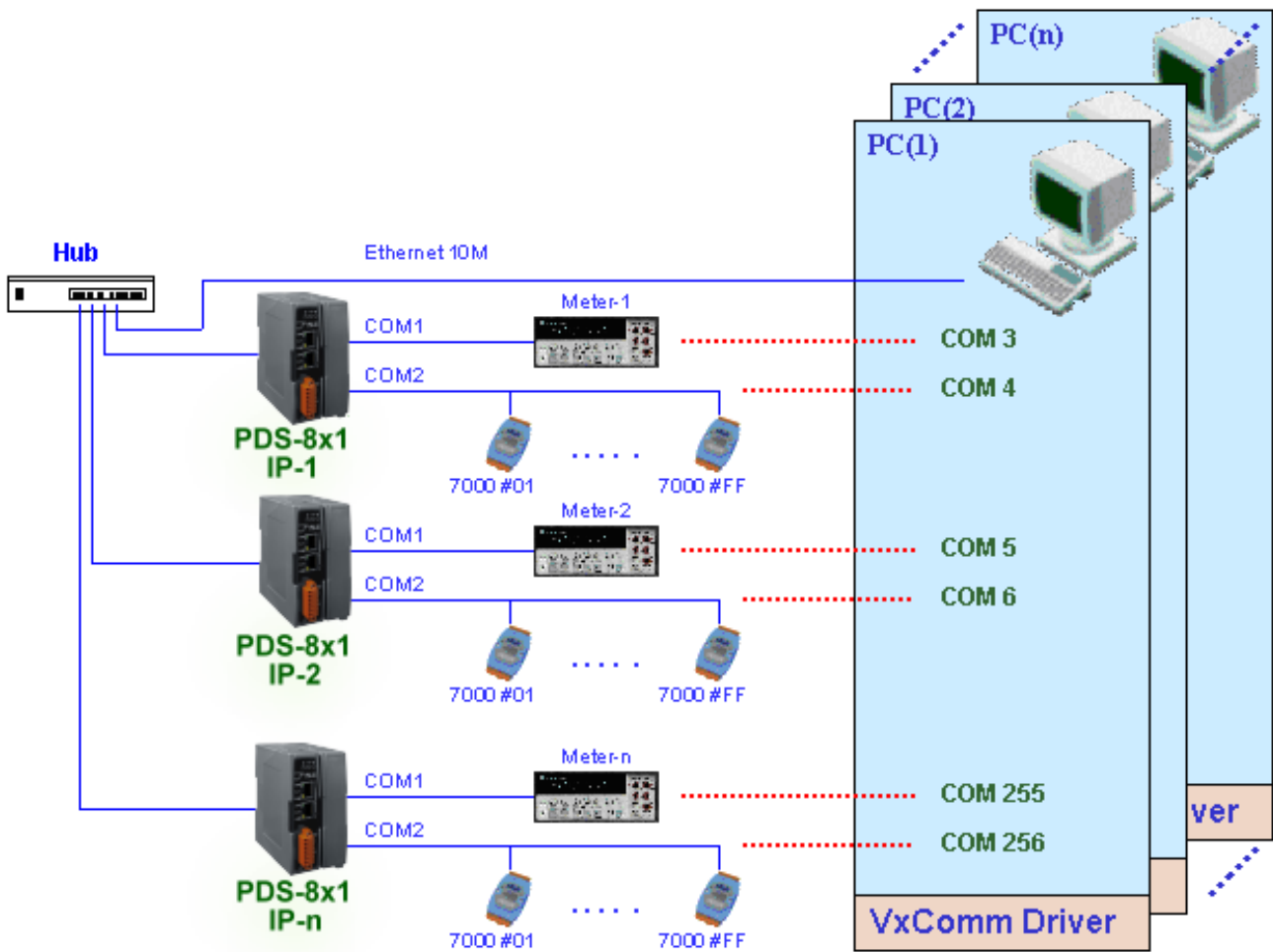

The VxComm driver controls all the details of the Ethernet TCP/IP programming technique, meaning that, with the assistance of PDS-8x1 controller and VxComm technology, your COM Port program will be able to access your serial devices through the Ethernet in the same way as through a COM Port.

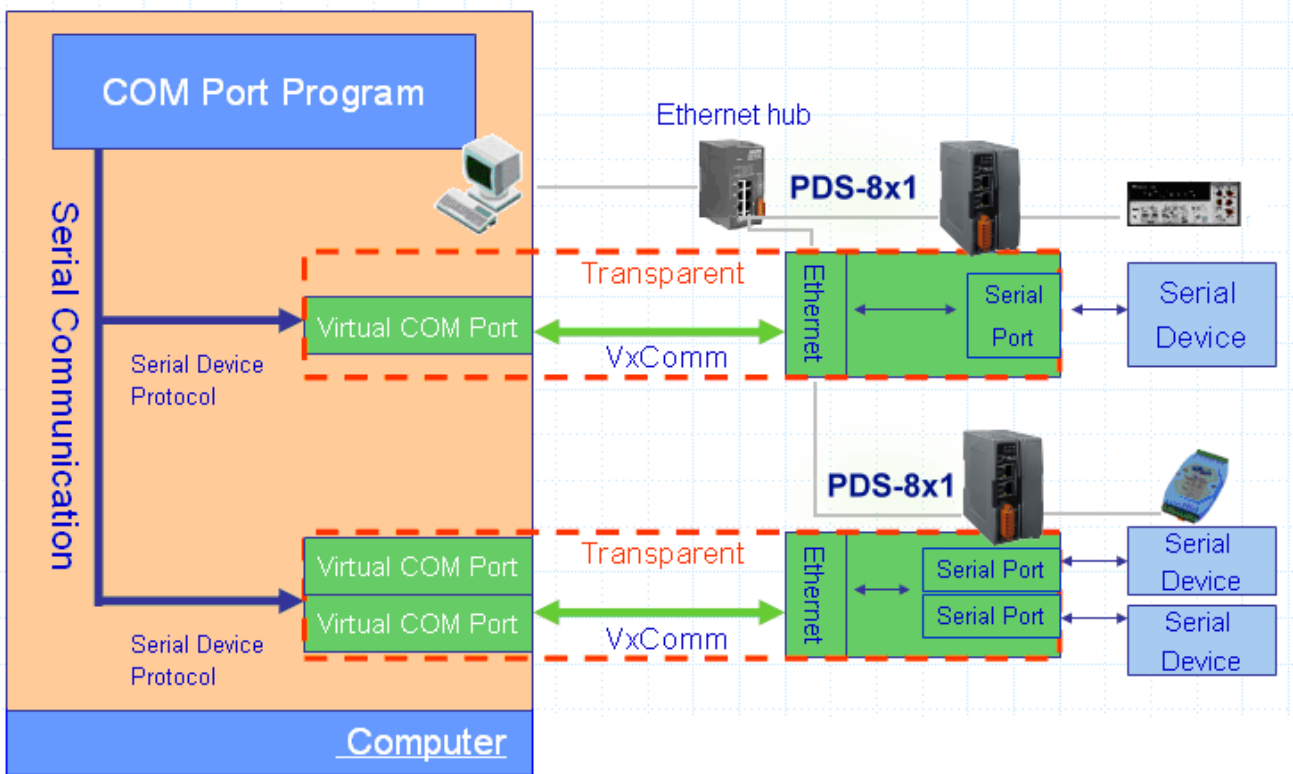

## 1.4 Web Server Technology

Web server technology enables the PDS-8x1 controller to be configured via a standard web browser interface, e.g. Google Chrome, Internet Explorer, or Firefox, etc. This means that it is easy to check the configuration of the PDS-8x1 controller via an Ethernet network without needing to install any other software tools, thereby reducing the learning curve required for maintaining the device.

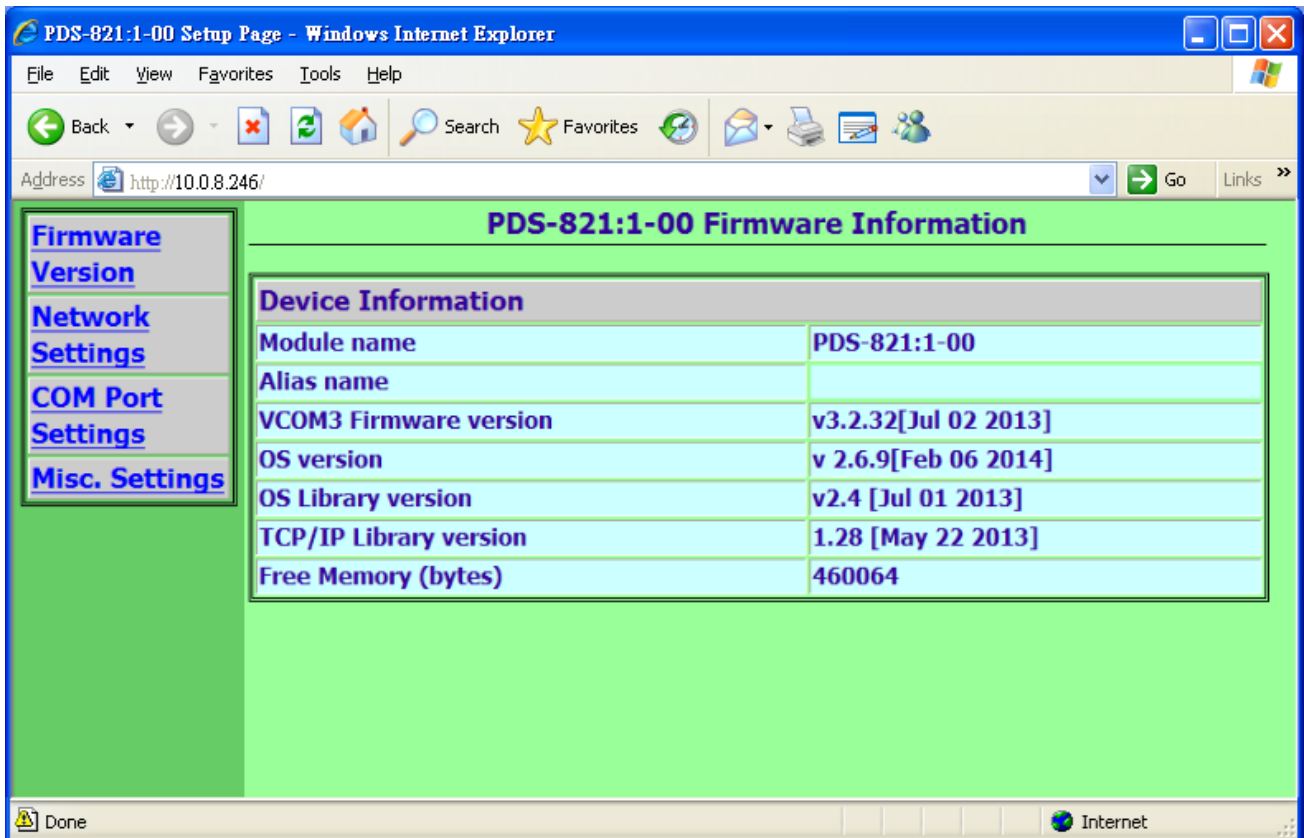

## 2. Hardware Information

This chapter provides a detailed description of the front panel, the hardware specifications, the pin assignments, the wiring notes and the dimensions for the PDS-8x1 controller.

### 2.1 Specifications

Models	PDS-811	PDS-821
<b>CPU</b>		
CPU	80186-80 MHz or compatible	
SRAM	512 KB	
Flash Memory	512 KB	
EEPROM	16 KB	
Built-in Watchdog Timer	Yes	
I/O Expansion Slots	1 Slot	2 Slots
<b>Communication Interface</b>		
COM1 (Console)	RS-232 (TxD, RxD, GND)	
Ethernet	2-port 10/100 Base-TX Ethernet Switch (Auto-negotiating, auto MDI/MDI-X, LED indicator)	
<b>COM Port Formats</b>		
Speed	115200 bps Max.	
Data Bit	7, 8	
Parity	None, Even, Odd	
Stop Bit	1	
<b>LED Indicators</b>		
TxD/RxD	Yes (for COM1 console port)	
System	Yes	
<b>Power</b>		
ESD Protection	Yes (with Frame Ground)	
Protection	Power Reverse Polarity Protection	
Required Supply Voltage	+10 V <sub>DC</sub> ~ +30 V <sub>DC</sub> (non-regulated)	
Power Consumption	0.6 A @ 5 V for CPU and Backplane, 1.0 A @ 5 V for Plug-in Modules, Total: 8 W	
<b>Mechanism</b>		
Flammability	Fire Retardant Materials (UL94-V0 Level)	
Dimension (W x H x D)	64 mm x 110 mm x 120 mm	95 mm x 110 mm x 132 mm
Installation	DIN-Rail	DIN-Rail or Wall mounting
<b>Environment</b>		
Operating Temperature	-25 ~ +75 °C	
Storage Temperature	-40 ~ +80 °C	
Humidity	5 ~ 95% RH, non-condensing	

## 2.2 Features

- Incorporate Serial Devices in an Ethernet network
- Virtual COM for 32-bit and 64-bit Windows XP/2003/Vista/7/8
- Watchdog Timer suitable for use in harsh environments
- 2-port 10/100 Base-TX Ethernet Switch (Auto-negotiating, auto MDI/MDI-X, LED indicator)
- ESD Protection and Frame Ground Design
- Built-in High Performance MiniOS7 from ICP DAS
- "Virtual COM" extends PC COM ports
- Programmable Internet/Ethernet Controller
- Power Reverse Polarity Protection
- 3-wire RS-232 Console Port
- RS-232 TxD/RxD LED Indicators
- System Status LED Indicator
- RoHS Compliant & no Halogen
- Low power consumption

## 2.3 Applications

- Factory Automation
- Building Automation
- Home Automation

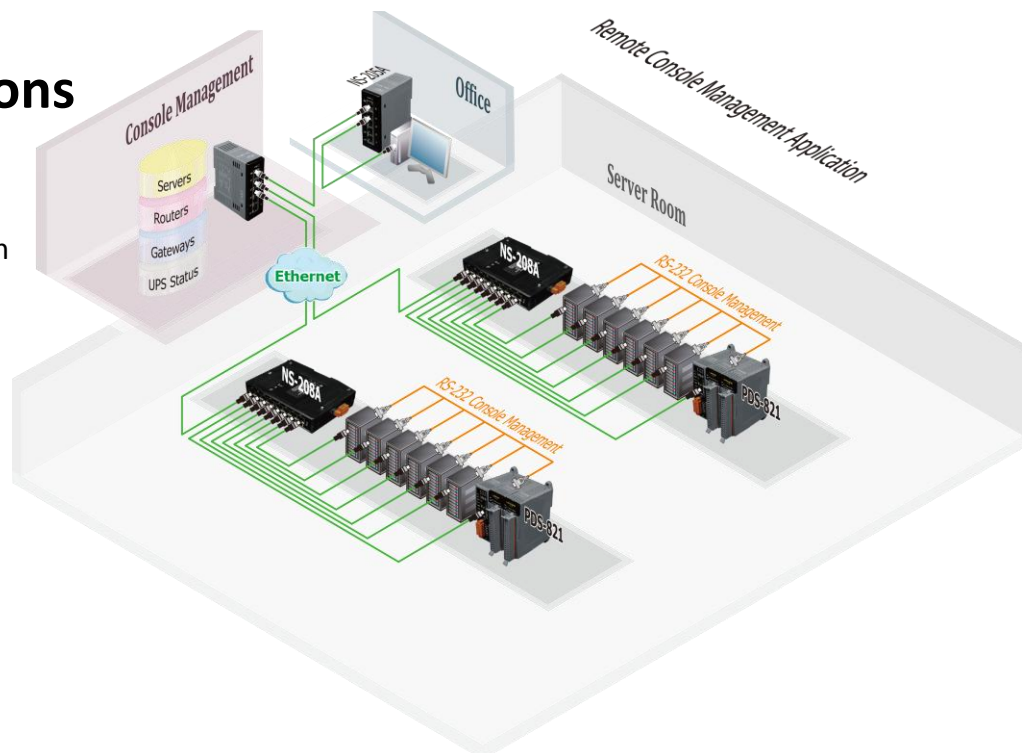

## 2.4 Appearance

### Front View

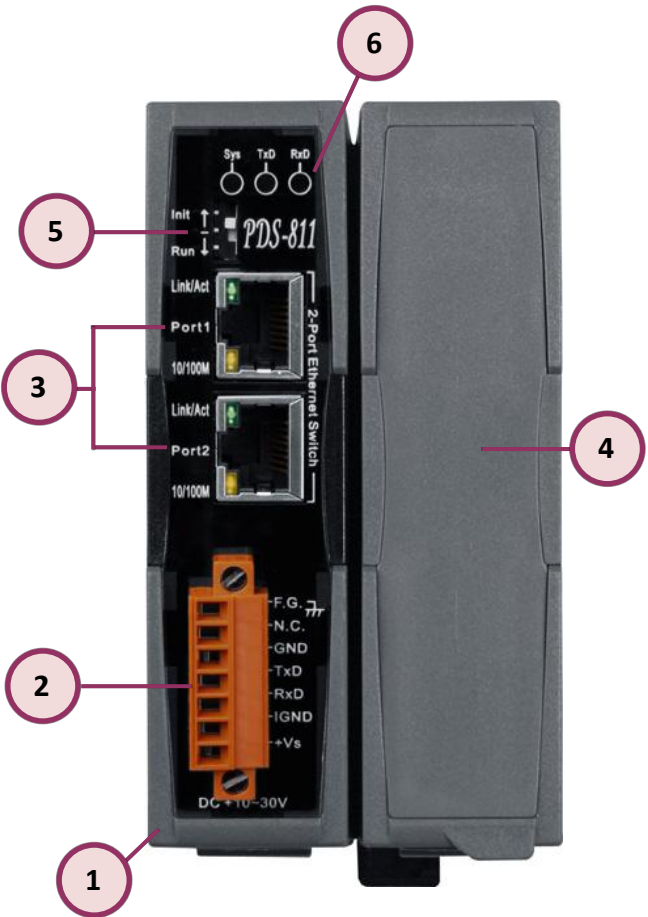

### 1. Robust Insulated and Fire-retardant Case

### 2. COM1: RS-232

For more detailed information regarding the pin assignments for the COM1 ports, refer to Section 2.6.1.

### 3. 2-Port 10/100 Base-TX Ethernet Switch

The PDS-8x1 controller are equipped with two RJ-45 jack that is used as the 10/100 Base-TX Ethernet port and features networking capability. When an Ethernet link is detected and an Ethernet packet is received, the **Link/Act LED (Green)** indicator and the **10/100 M LED (Yellow)** indicator will be illuminated.

### 4. I/O Expansion Slots

The PDS-811 has one I/O expansion slot, while PDS-821 has two I/O expansion slots that can be used to attach various 2- or 4-port serial communication modules. Therefore, a maximum of 4 serial ports can be installed on the PDS-811 or a maximum of 8 serial ports can be installed on the PDS-821.

### 5. LED indicator

Once power is supplied to the PDS-8x1 controller, the system LED indicator will illuminate. An overview of the LED functions is given below:

Name	Function	LED Behavior
Sys	Running Firmware	ON (Red)
TxD	Serial Port Busy	Flashing (Yellow)
RxD		Flashing (Green)

## 6. Operating Mode Switch

**Init Mode:** Uses factory settings and allows the firmware to be updated

**Run Mode:** Firmware operation mode

For PDS-8x1 controller, the operating mode switch is set to the **Run** position by default. In order to update the firmware for the PDS-8x1 controller, the switch must be moved from the **Run** position to the **Init** position. The switch must be returned to the Run position after the update is complete.



## 2.5 Dimensions

### ■ PDS-811 :

Units: mm

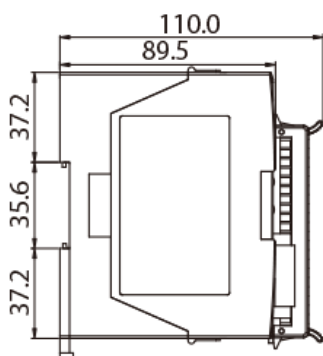

Left Side View

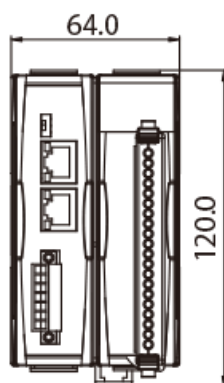

Front View

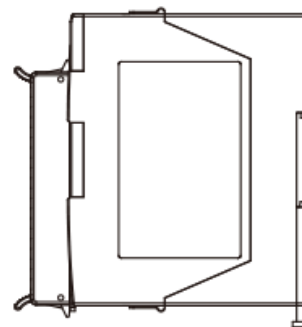

Right Side View

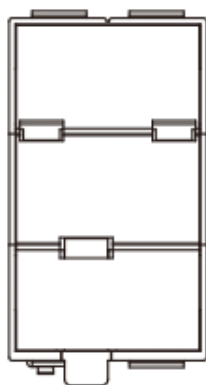

Rear View

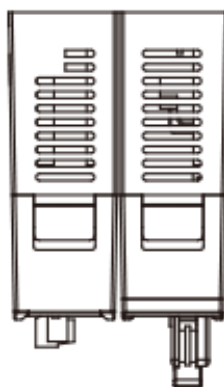

Top View

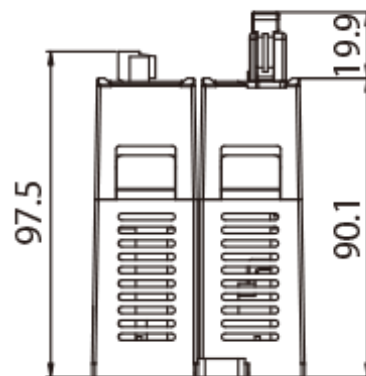

Bottom View



■ PDS-821 :

Units: mm

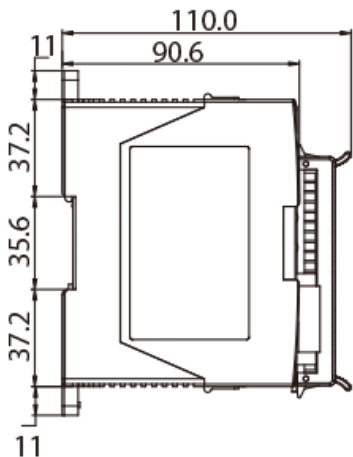

Left Side View

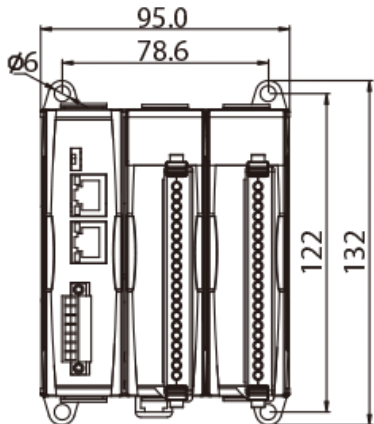

Front View

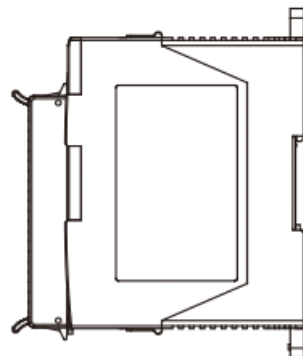

Right Side View

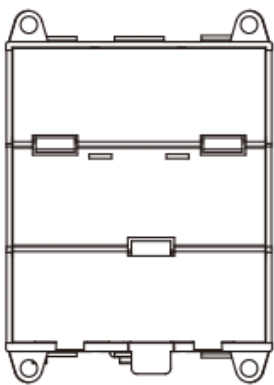

Rear View

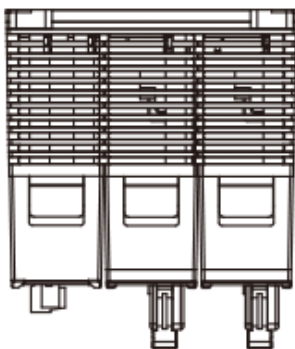

Top View

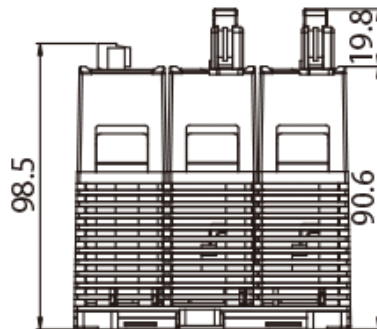

Bottom View

## 2.6 Pin Assignments

### 2.6.1 PDS-811 and PDS-821

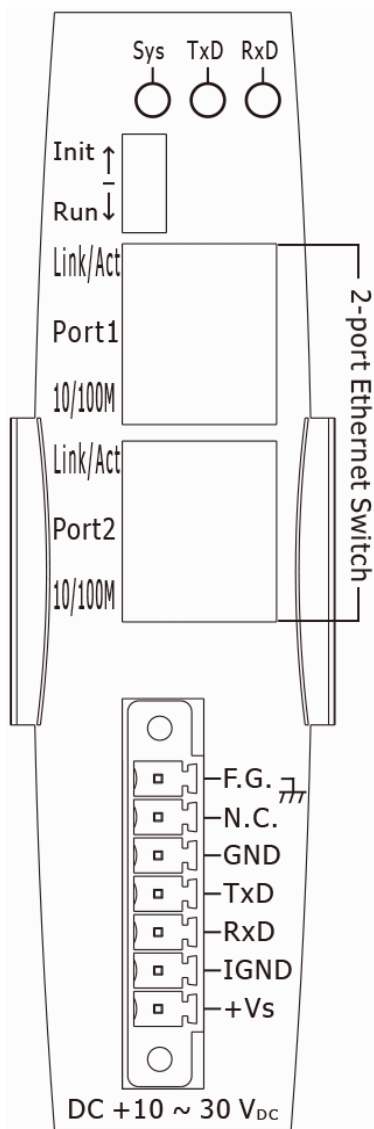

## 2.6.2 I-8112iW

The I-8112iW is an optional serial module that provides 2 isolated RS-232 serial ports.

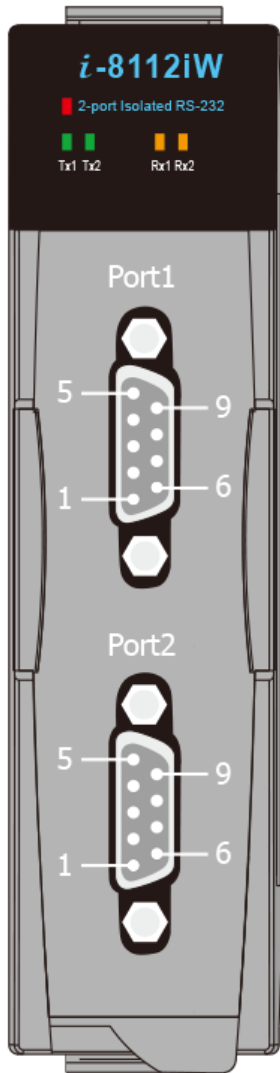

Pin Assignment	Terminal No.	Terminal No.	Pin Assignment
GND1	05	09	RI1
DTR1	04	08	CTS1
TxD1	03	07	RTS1
RxD1	02	06	DSR1
DCD1	01		

Port1 9-Pin Male D-Sub Connector

Pin Assignment	Terminal No.	Terminal No.	Pin Assignment
GND2	05	09	RI1
DTR2	04	08	CTS2
TxD2	03	07	RTS2
RxD2	02	06	DSR2
DCD2	01		

Port2 9-Pin Male D-Sub Connector

### 2.6.3 I-8114W

The I-8114W is an optional serial module that provides 4 non-isolated RS-232 serial ports.

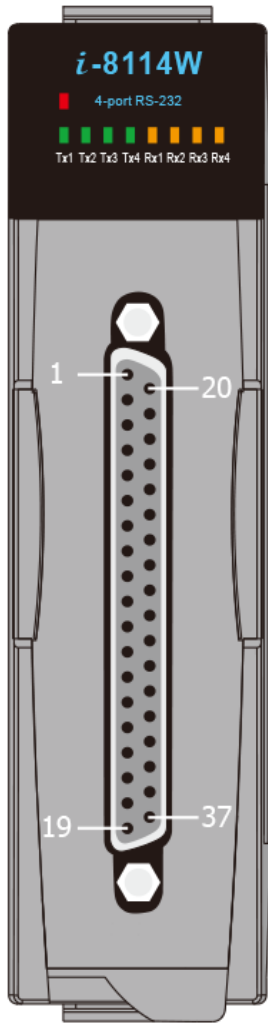

Pin Assignment	Terminal No.	Pin Assignment
N.C.	01	
DCD3	02	20 RI3
GND	03	21 DTR3
CTS3	04	22 DSR3
RxD3	05	23 RTS3
RI4	06	24 TxD3
DTR4	07	25 DCD4
DSR4	08	26 GND
RTS4	09	27 CTS4
TxD4	10	28 RxD4
DCD2	11	29 RI2
GND	12	30 DTR2
CTS2	13	31 DSR2
RxD2	14	32 RTS2
RI1	15	33 TxD2
DTR1	16	34 DCD1
DSR1	17	35 GND
RTS1	18	36 CTS1
TxD1	19	37 RxD1

37-Pin Female D-Sub Connector

## 2.6.4 I-8114iW

The I-8114iW is an optional serial module that provides 4 isolated RS-232 serial ports.

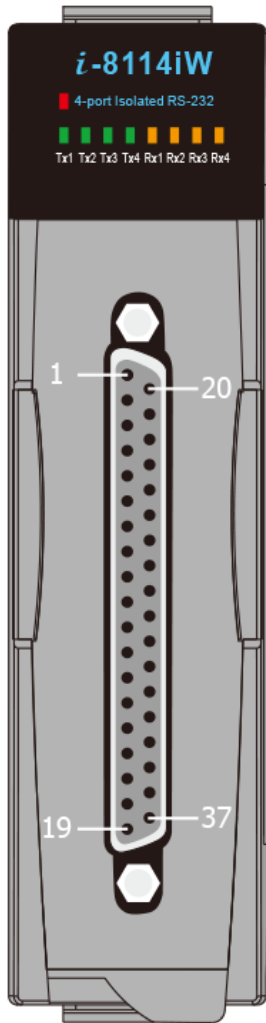

Pin Assignment	Terminal No.	Pin Assignment
N.C.	01	N.C.
N.C.	02	N.C.
GND3	03	N.C.
CTS3	04	N.C.
RxD3	05	RTS3
N.C.	06	TxD3
N.C.	07	N.C.
N.C.	08	N.C.
RTS4	09	GND4
TxD4	10	CTS4
N.C.	11	RxD4
GND2	12	N.C.
CTS2	13	N.C.
RxD2	14	RTS2
N.C.	15	TxD2
N.C.	16	N.C.
N.C.	17	GND1
RTS1	18	CTS1
TxD1	19	RxD1

37-Pin Female D-Sub Connector

## 2.6.5 I-8142iW

The I-8142iW is an optional serial module that provides 2 isolated RS-422/485 serial ports.

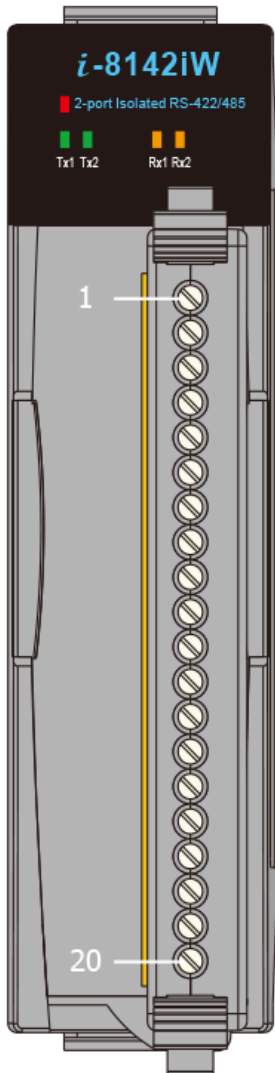

Terminal No.	Pin Assignment
01	D1+/TxD1+
02	D1-/TxD1-
03	RxD1+
04	RxD1-
05	GND1
06	D2+/TxD2+
07	D2-/TxD2-
08	RxD2+
09	RxD2-
10	GND2
11	N.C.
12	N.C.
13	N.C.
14	N.C.
15	N.C.
16	N.C.
17	N.C.
18	N.C.
19	N.C.
20	N.C.

## 2.6.6 I-8144iW

The I-8144iW is an optional serial module that provides 4 isolated RS-422/485 serial ports.

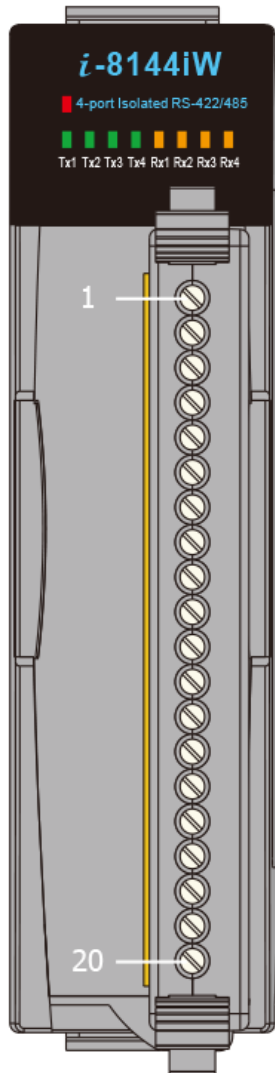

Terminal No.	Pin Assignment
01	D1+/TxD1+
02	D1-/TxD1-
03	RxD1+
04	RxD1-
05	GND1
06	D2+/TxD2+
07	D2-/TxD2-
08	RxD2+
09	RxD2-
10	GND2
11	D3+/TxD3+
12	D3-/TxD3-
13	RxD3+
14	RxD3-
15	GND3
16	D4+/TxD4+
17	D4-/TxD4-
18	RxD4+
19	RxD4-
20	GND4

## 2.7 Wiring Notes for RS-232/485/422 Interfaces

### 2.7.1 RS-232 Wiring

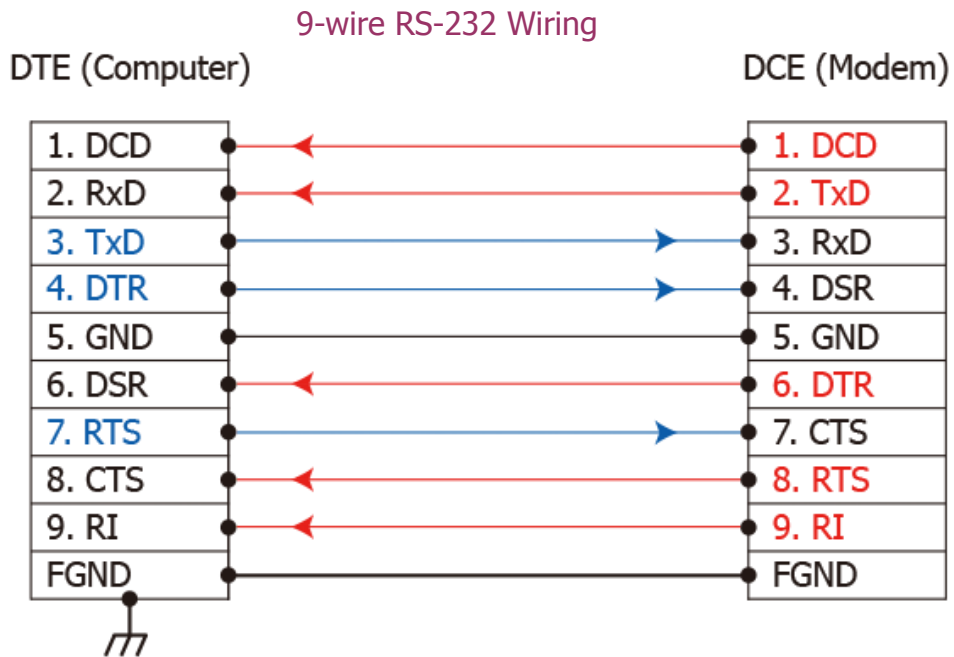
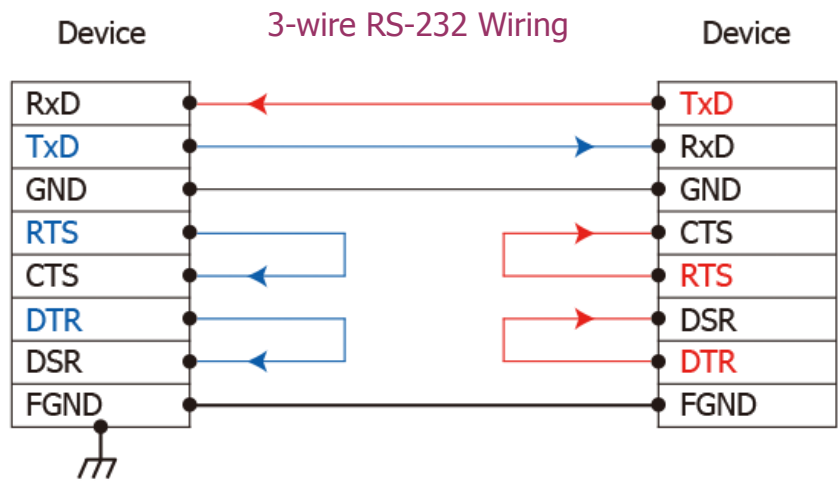

**Note:**

1. For 3-Wire RS-232 connections, it is recommended to short unused signals such as RTS/CTS and DTR/DSR, since some system may still check the CTS and DSR status.
2. FGND is the frame ground that soldered to DB9 metal-shield.



## 2.7.2 RS-422 Wiring

4-wire RS-422 Wiring

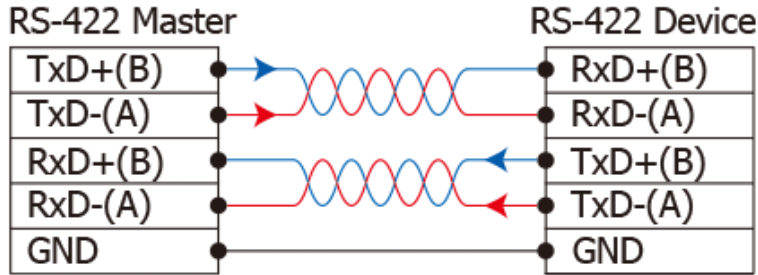

4-wire RS-422 Isolated Wiring

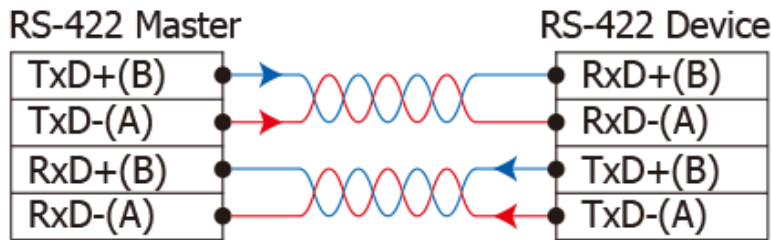

## 2.7.3 RS-485 Wiring

2-wire RS-485 Wiring

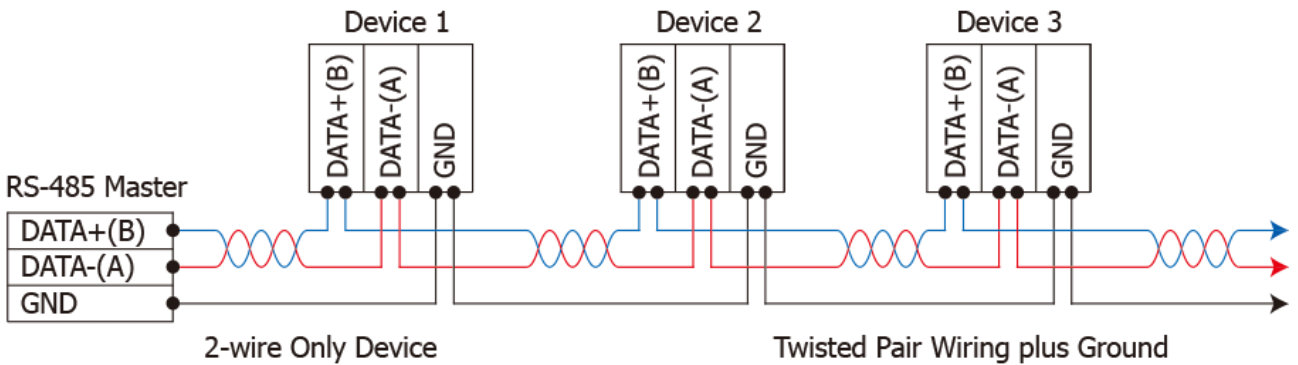

### 2-wire RS-485 Isolated Wiring

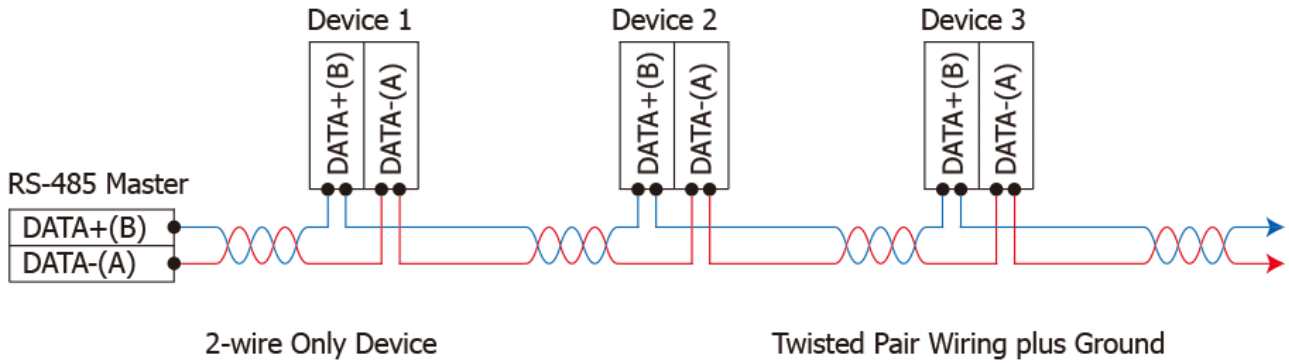

#### Note:

1. Usually, you have to connect all signal grounds of RS-422/485 devices together to reduce common-mode voltage between devices.
2. Twisted-pair cable must be used for the DATA+/- wires.
3. Both two ends of the cable may require a termination resistor connected across the two wires (DATA+ and DATA-). Typically 120  $\Omega$  resistors are used.
4. The Data+ and B pins are positive-voltage pins, and Data- and A pins are negative-voltage pins in the above figure. The B/A pins may be defined in another way depending on devices, please check it first.

### 3. Setting up the PDS-8x1 Controller

This chapter provides detailed information about the “Self-Test” process, which is used to confirm that the PDS-8x1 controller is operating correctly. Before beginning the “Self-Test” process, the wiring test, Ethernet configuration and VxComm utility driver installation procedures must first be fully completed. Follow the procedure described below:

**Step 1: Connect the Power Supply and the Host PC**

1. Ensure that the network settings on your PC are configured correctly.
2. Ensure that the Windows firewall or any Anti-Virus firewall software is correctly configured or temporarily disable these functions; otherwise the “**Search Servers**” function in the VxComm Utility may not work as required. You may need to contact your System Administrator for more details of how to do this.
3. Check that the Init/Run switch is in the “**Run**” position.



4. Remove the I/O expansion slot cover from the PDS-8x1 controller, and then inserts a serial module (optional) in the I/O expansion slot. (For example: I-8114iW)

5. Connect both the PDS-8x1 and the Host computer to the same sub-network or the same Ethernet Switch.
6. **Short the RxD and TxD pins** of the PDS-8x1 controller for self-test.
7. **Short the TxD1 (Pin 19) and RxD1 (Pin 37) pins** of the 4-Port I-8114iW module (RS-232 bus) for example of self-test.
8. **Supply +24 V<sub>DC</sub> (+10 ~ +30 V<sub>DC</sub>) power** to the PDS-8x1 controller.

The wiring diagram is as follows:

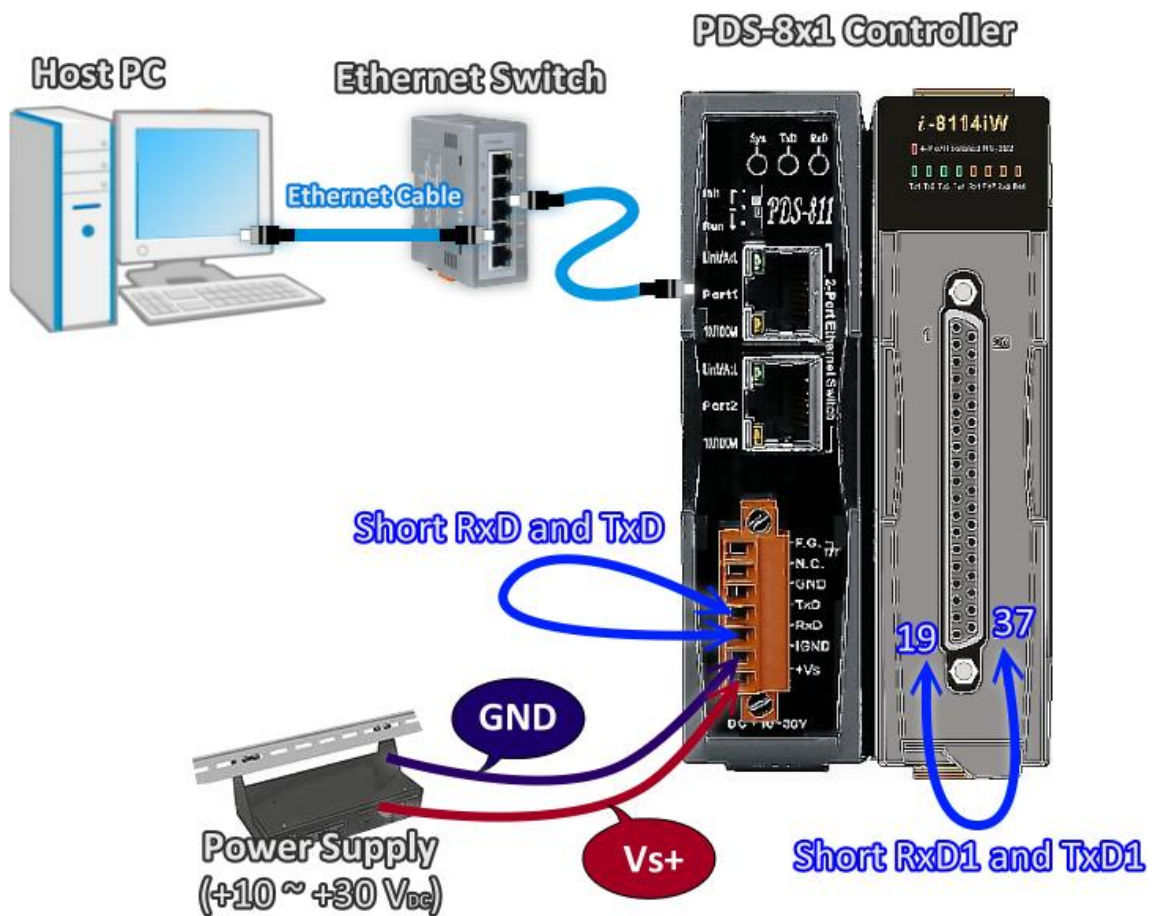

9. Verify that the System LED indicator is flashing on the PDS-8x1 controller.



### Step 2: Install the VxComm Utility

The VxComm Utility can be obtained from either the companion CD-ROM, the ICP DAS FTP site, or the ICP DAS web site. The location of the install files on the CD and the download addresses are shown below:



CD:\\ NAPDOS\\DRiver\\VxComm\_Driver\\2k\\



[http://ftp.icpdas.com/pub/cd/8000cd/napdos/driver/vxcomm\\_driver/2k/](http://ftp.icpdas.com/pub/cd/8000cd/napdos/driver/vxcomm_driver/2k/)

### Step 3: Search for the PDS-8x1 controller on the Ethernet network

1. Open the VxComm Utility and then click the **“Search Servers”** button to search for the PDS-8x1 controller.
2. Once the search process is complete, double-click the name of the PDS-8x1 controller to open the **“Configure Server”** dialog box.

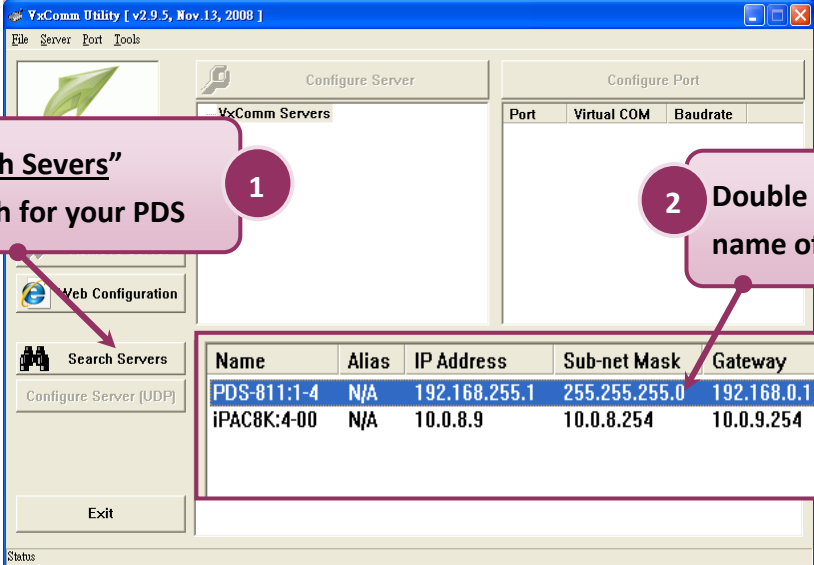

Click the **“Search Servers”** button to search for your PDS

1

2 Double click the name of your PDS

Name	Alias	IP Address	Sub-net Mask	Gateway	MAC Address
PDS-811:1-4	N/A	192.168.255.1	255.255.255.0	192.168.0.1	00:0d:e0:e0:37:2b
iPAC8K:4-00	N/A	10.0.8.9	10.0.8.254	10.0.9.254	00:0d:e0:e0:eb:17

- Enter the network settings information, including the **IP, Mask and Gateway addresses**, and then click **“OK”** button. The new settings for the PDS-8x1 controller will take effect within 2 seconds. If you don't know the correct network configuration information, contact your Network Administrator to obtain the details.

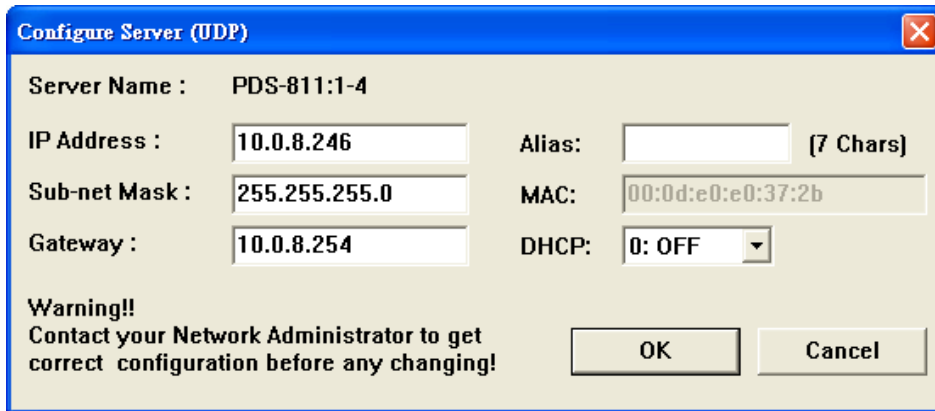

**Step 4: Configuring the Virtual COM Ports**

- Wait 2 seconds and then click the **“Search Servers”** button again to ensure that the PDS-8x1 controller is working correctly with the new configuration.

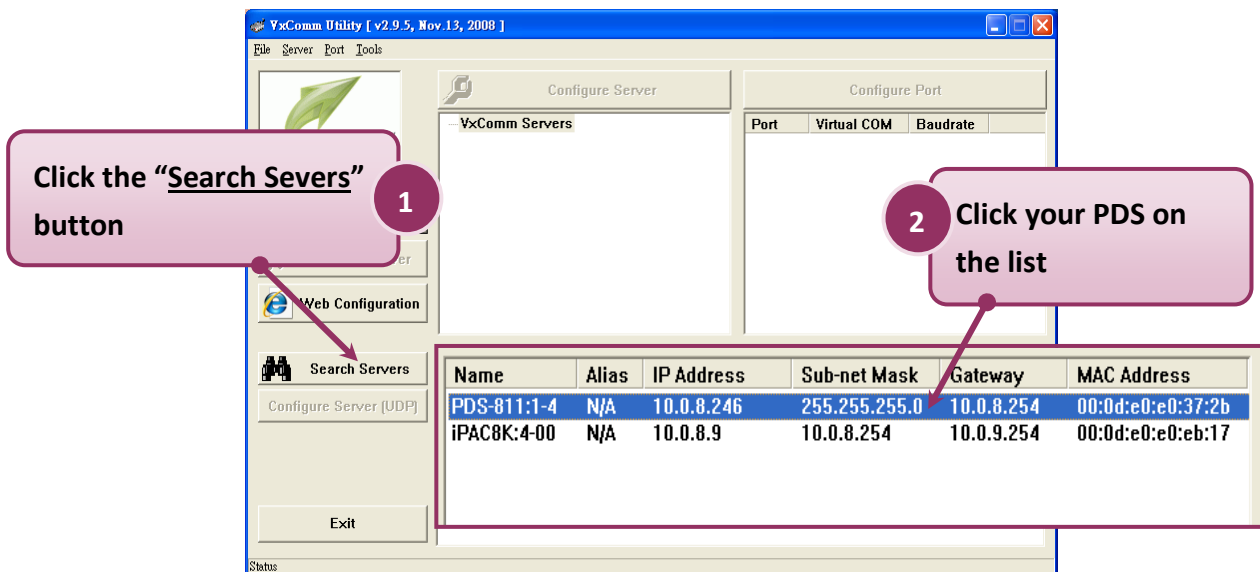

- Click the **"Add Server[s]"** button. Assign a COM Port number and click **"OK"** to save your settings.

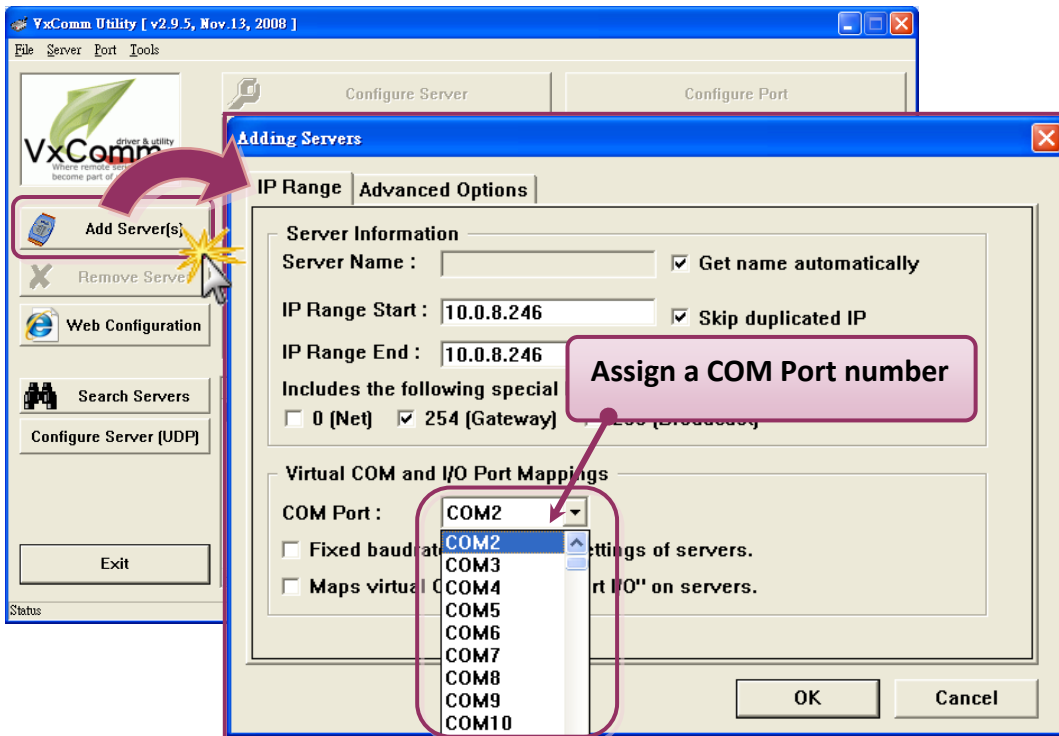

- Click on PDS-8x1 controller name or slot that your module plugged in, and then check the virtual COM port mappings on the PC.

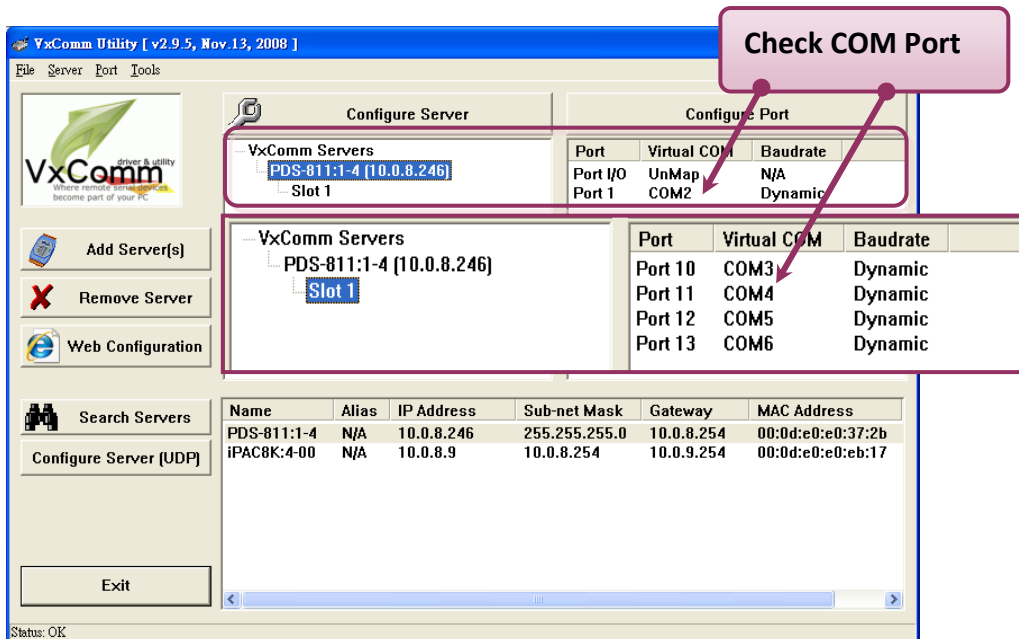

- Click **“Tools”** → **“Restart Driver”**, and then click the **“Restart Driver”** button.

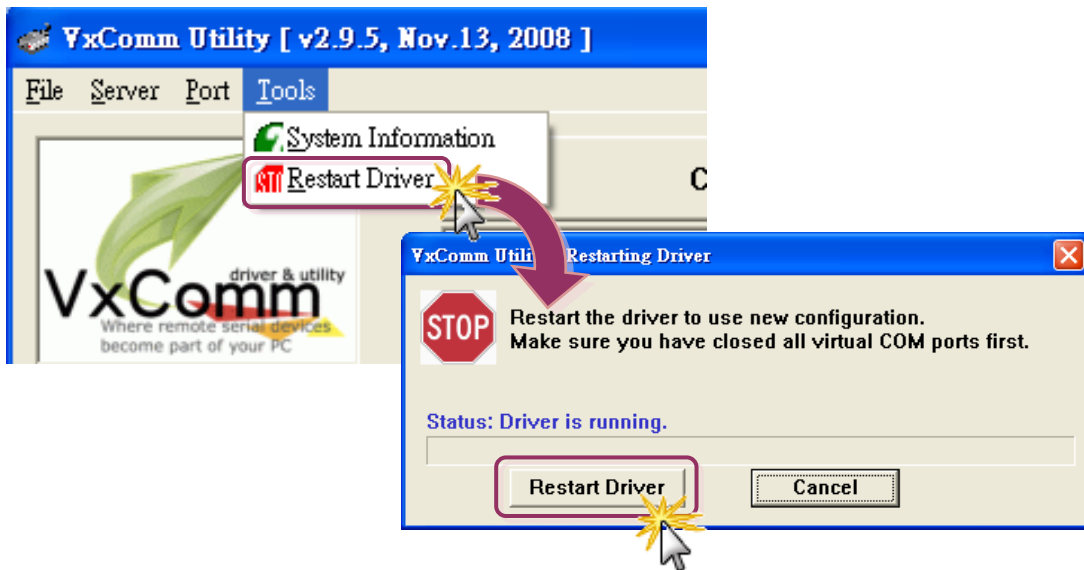

**Step 5: Testing your PDS-8x1 controller**

- Click on PDS-8x1 controller name and right click Port 1 then choose the **“Open COM Port”** item.

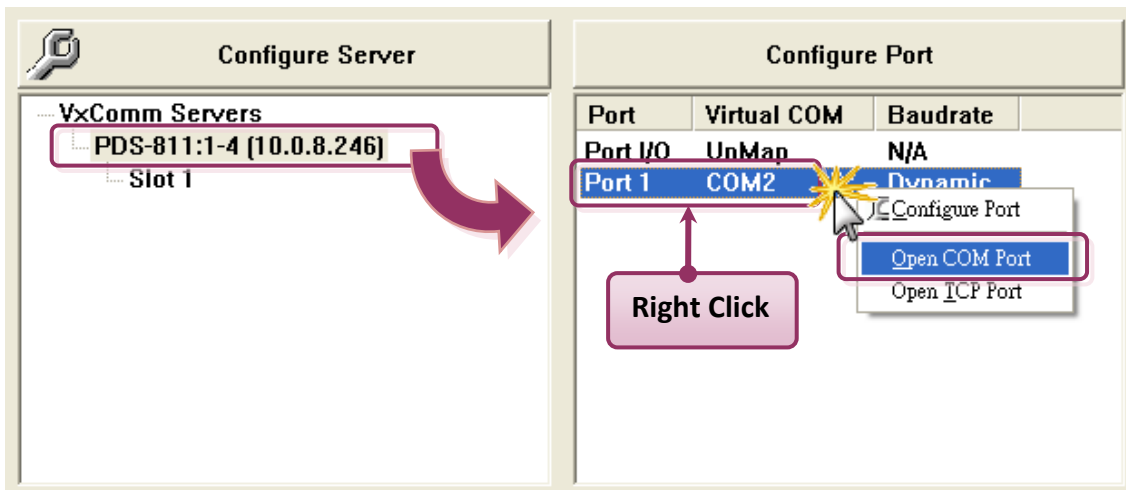



2. Check that the configuration of the COM Port is correct and then click the **“Open COM”** button.

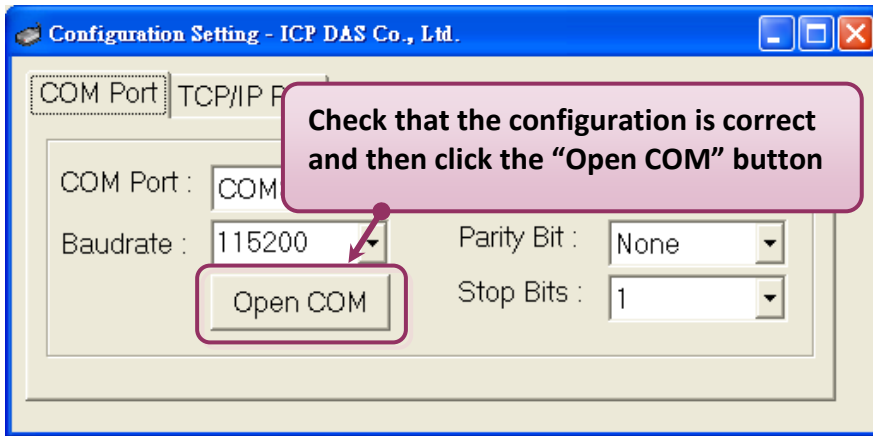

3. Type a string in the send field then click the **“Send”** button. If a response is received, it will be displayed in the received field.

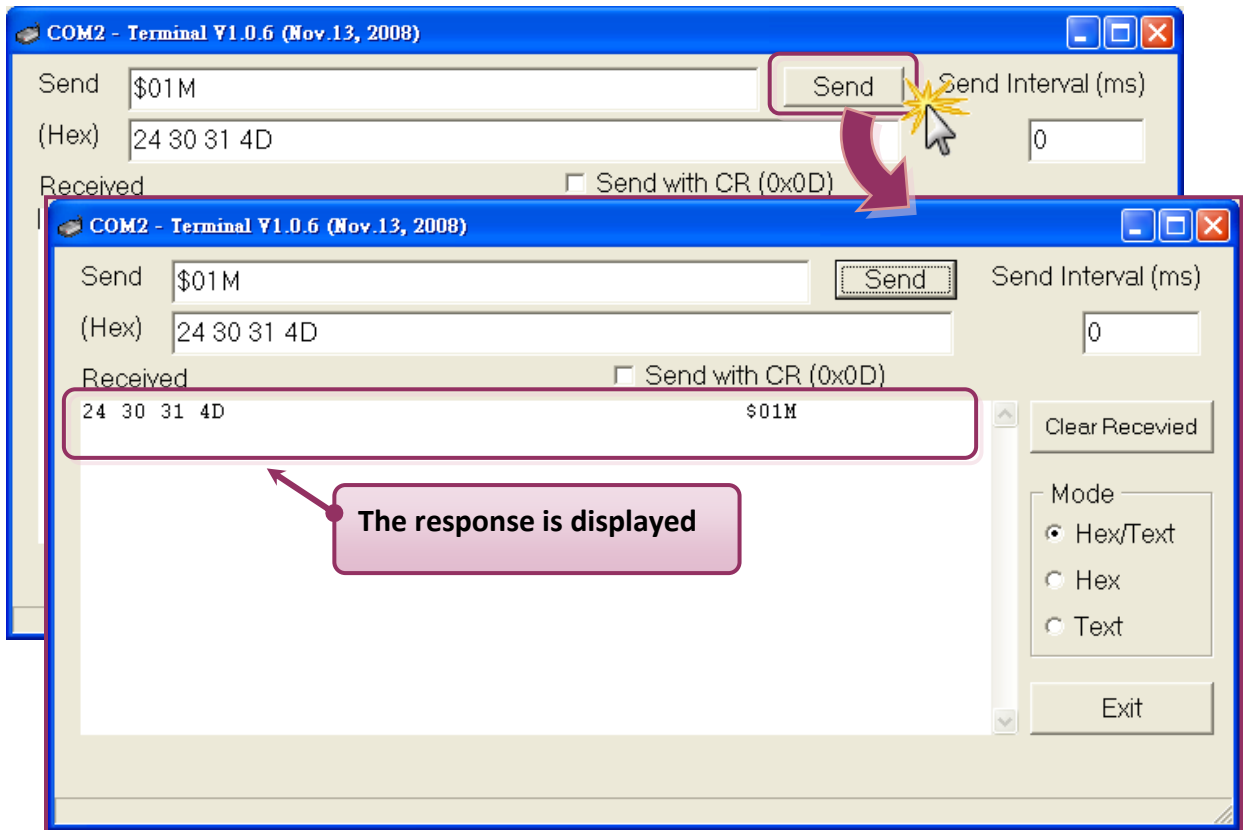

**Step 5: Testing your Serial Modules (Optional)**

1. Click on serial modules (Slot) and right click Port 10 then choose the **“Open COM Port”** item.

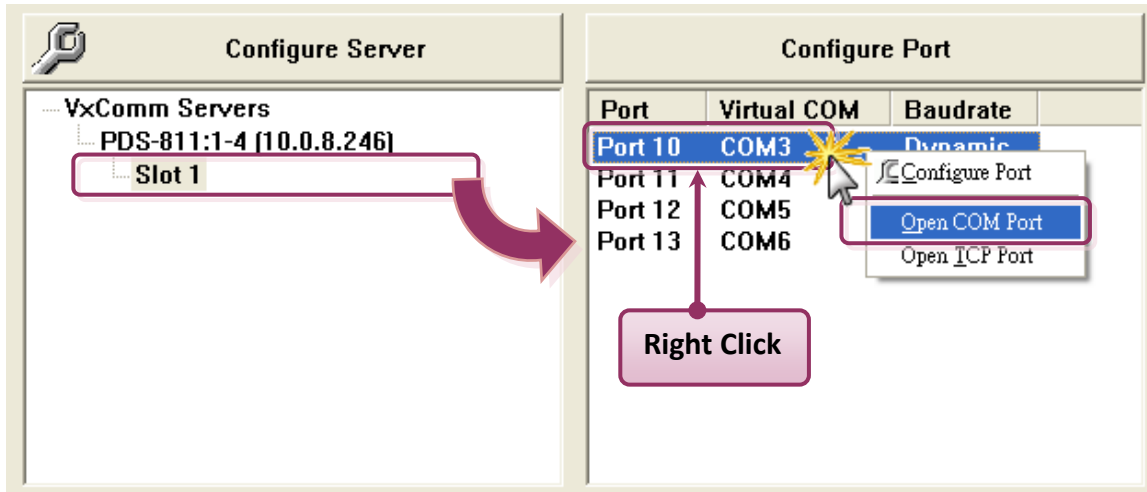

2. Check that the configuration of the COM Port is correct and then click the **“Open COM”** button.

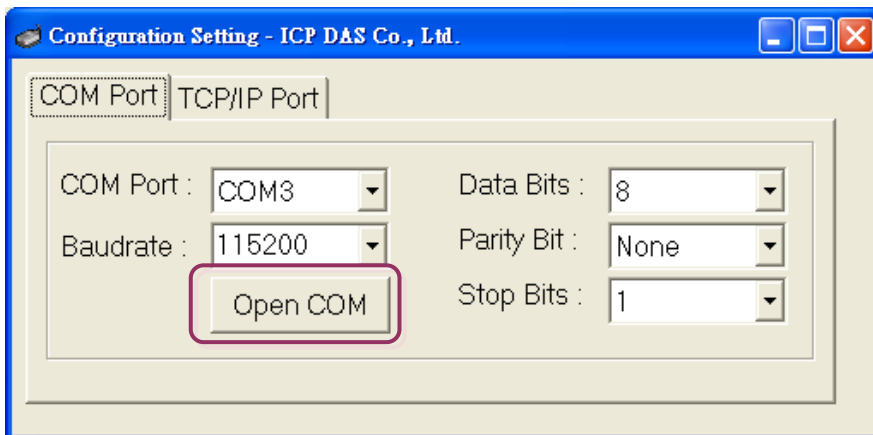

3. Type a string in the send field then click the **“Send”** button. If a response is received, it will be displayed in the received field.

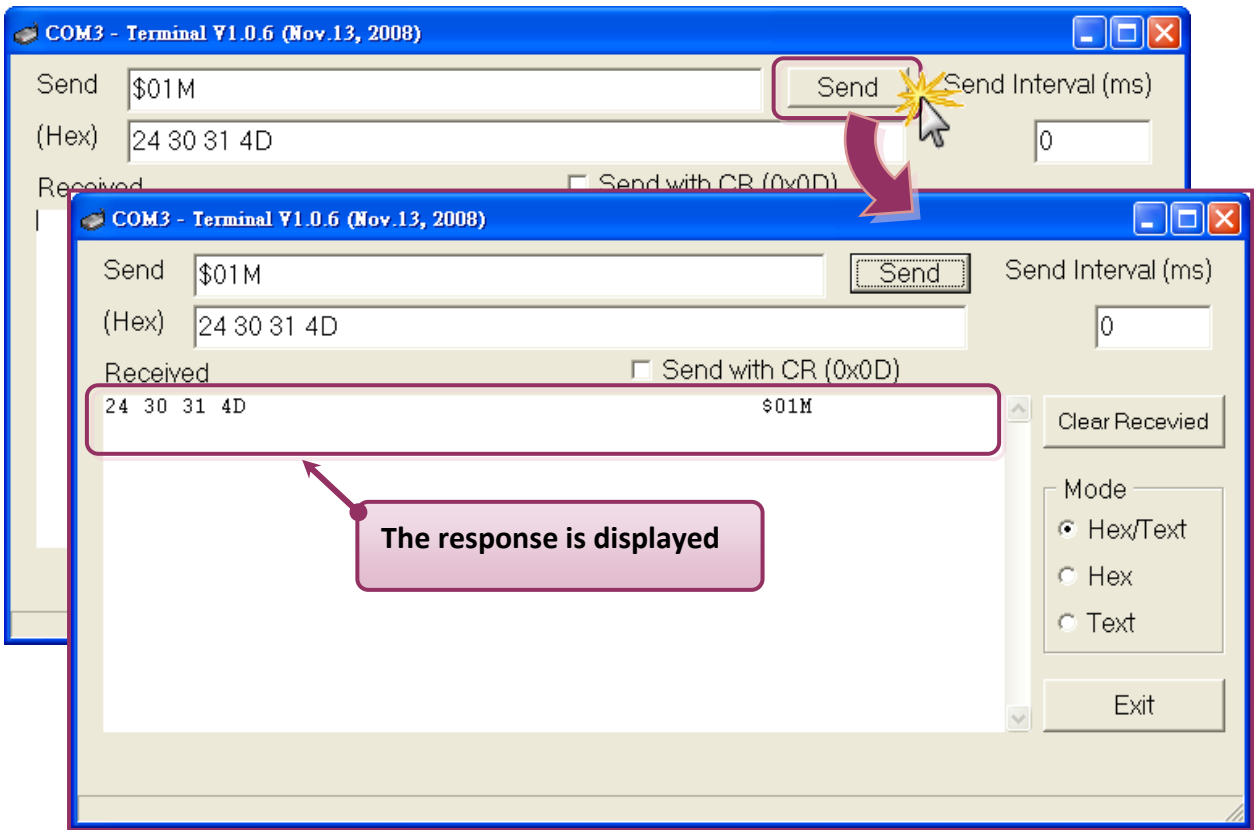

**Note:**

While using RS-485 modules (e.g. I-8144iW), you should wire the Data1+ with Data2+ signals, and wire the Data1- with Data2- signals for self-test. Then open the first two COM ports, send data to one and receive data from the other.

4. If the test is successful, then your COM port program should now be able to work with this Virtual COM Port.

## 4. Web Configuration

Once the PDS-8x1 controller has been correctly configured and is functioning on the network normally, the configuration details can be retrieved or modified using either the VxComm Utility or a standard web browser.

### 4.1 Logging in to the PDS-8x1 Web Server

The embedded PDS-8x1 controller web server can be accessed from any computer that has an Internet connection.

**Step 1: Open a new browser window.**

Open a web browser, for example, Google Chrome, Firefox or Internet Explorer, which are reliable and popular Internet browsers that can be used to configure PDS-8x1 controller.



**Step 2: Enter the URL for the PDS-8x1 web server**

Ensure that you have correctly configured the network settings for the PDS-8x1 controller (refer to [Chapter 3 Setting up the PDS-8x1 Controller](#) for detailed instructions), and then enter the URL address of the PDS-8x1 in the address bar of the browser or click the “Web” button in the VxComm Utility to log in to the web configuration pages.

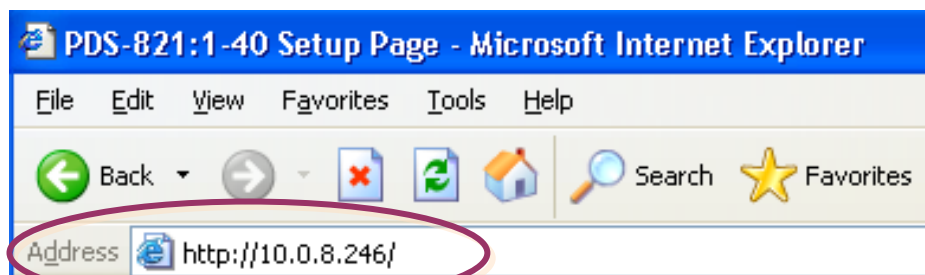

**Step 3: Log in to the PDS-8x1 Web Server**

After logging into the PDS-8x1 web server, the main page will be shows firmware information of the PDS-8x1 controller.

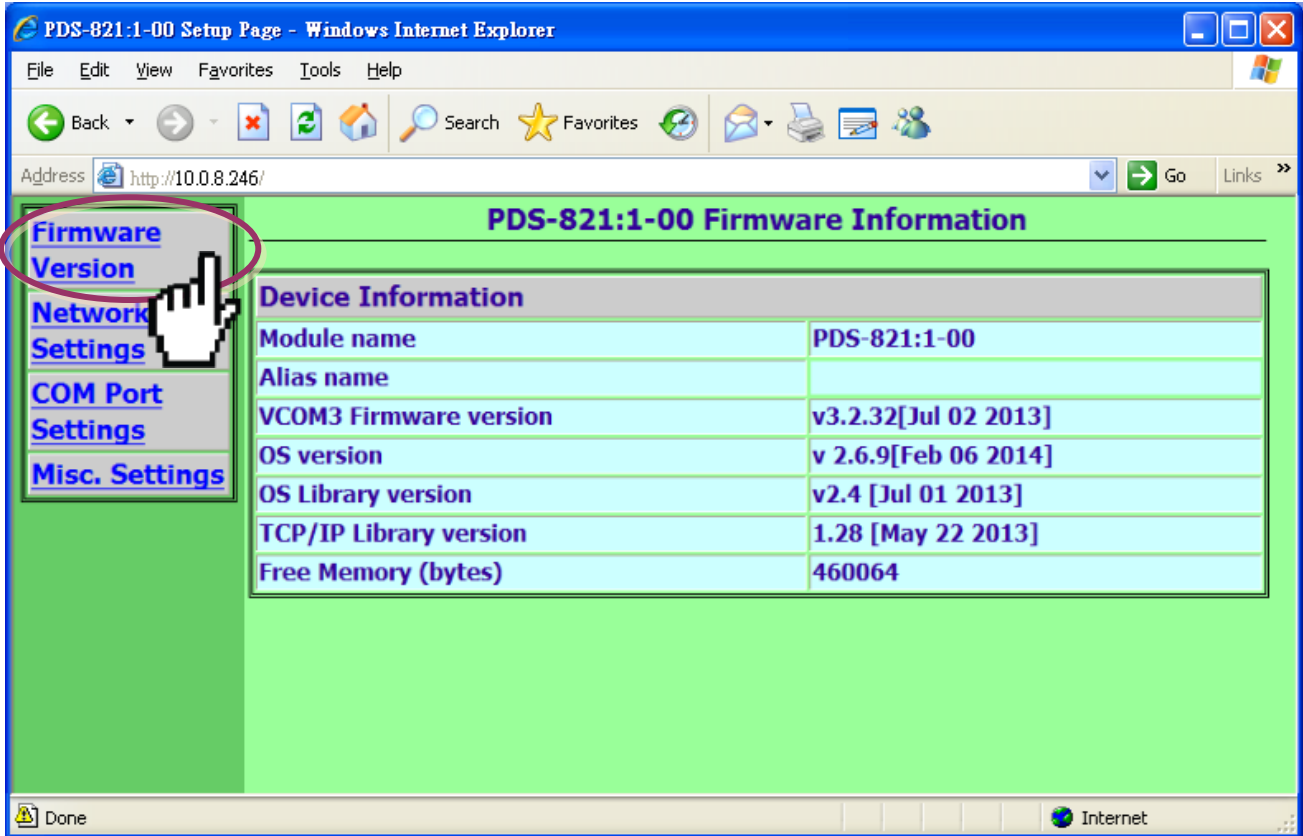

## 4.2 Network Setting

The Network Settings section provides information related to most important network settings for the PDS-8x1 controller, including the **IP Address**, **Subnet Mask** and **Default Gateway** values, etc. If they do not match, the PDS-8x1 controller will not operate correctly. If the settings are changed while the module is operating, any connection currently in use will be lost and an error will occur.

**PDS-821:1-00 Network(TCP/IP) Setup Page**

Network Settings	Current	New
IP Address	10.0.8.246	<input type="text"/>
Subnet Mask	255.255.255.0	<input type="text"/>
Gateway	10.0.8.254	<input type="text"/>
DHCP Client	0	<input type="checkbox"/>
UDP Search	2	<input type="checkbox"/>
Command Port	10000	<input type="text"/>
Web Server	1	<input type="checkbox"/>
Telnet Server	1	<input type="checkbox"/>
Ping Gateway at start	0	<input type="checkbox"/>
TCP ACK Delay (ms)	50	<input type="text"/>
Broadcast	1	<input type="checkbox"/>
Connection WDT timeout (ms)	0	<input type="text"/>
Network WDT timeout(System Timeout) (ms)	0	<input type="text"/>
Master IP	----	<input type="text"/>

Reset System  
 IP/MASK/GATEWAY changes only take effect after the system is rebooted

[Set IP Filter](#)

The following is an overview of the parameters contained in the Network Settings section:

Item	Description	Default
<b>IP Address</b>	If no DHCP server is installed on the network, the network settings can be configured manually.	
<b>Subnet Mask</b>	This parameter is used to assign the subnet mask for the PDS-8x1 controller. The subnet mask indicates which portion of the IP address is used to identify the local network or subnet.	
<b>Gateway</b>	This parameter is used to assign the IP Address of the Gateway to be used by the PDS-8x1 controller. A Gateway (or router) is a device that is used to connect an individual network to one or more additional networks.	
<b>DHCP Client</b>	<p>This parameter is used to enable or disable DHCP Client configuration function. It is recommended that the DHCP Client setting is kept as disabled, and using static network settings. This ensures your PDS-8x1 controller always using a fixed IP address, and you don't need to configure the virtual COM mappings again and again.</p> <p>0 = Disabled, 1 = Enabled</p>	
<b>UDP Search</b>	<p>This parameter is used to enable or disable UDP Search function.</p> <p>0 = Disabled 1 = Enabled 2 = Enable the UDP Search function until another client is connected.</p> <p>By keeping the UDP search setting as 2, the PDS-8x1 controller loading will be reduced. The VxComm Utility will not be able to search for this module until this module's clients are all disconnected.</p>	2
<b>Command Port</b>	<p>This parameter is used to configure the TCP Command Port to a custom value depending on your requirement. Note that if the TCP Command Port configuration setting is completed, the TCP port of serial port will be change, as follows: COM1= TCP Command Port + 1 COM2= TCP Command Port + 2 ...., and so on.</p> <p>The default TCP Command Port is 10000. Thus, the serial COM port1/port2 is 10001/10002, and so on.</p>	10000

<b>Web Server</b>	This parameter is used to enable or disable Web Server function. 0 = Disabled, 1 = Enabled	1
<b>Telnet Server</b>	This parameter is used to enable or disable Telnet Server function. 0 = Disabled, 1 = Enabled	1
<b>Ping Gateway at start</b>	If the setting is 1 (enabled), the PDS-8x1 controller will send a ping packet to the gateway during the power-on stage. It is used to inform the gateway that a PDS-8x1 controller (itself) has joined the network. 0 = Disabled, 1 = Enabled	0 (Disabled)
<b>TCP ACK Delay (ms)</b>	PDS-8x1 controller does not want to send an empty ACK followed by a TCP data packet 1ms later, every time. So it delays a little (TCP ACK Delay), and then can combine the ACK and data packet into one. This efficiency reduces the number of packets and reduces network loadings.	50 ms
<b>Broadcast</b>	This parameter is used to receive or reject UDP broadcast packets. 1 = receive UDP broadcast packets 0 = reject UDP broadcast packets	1
<b>Connection WDT timeout (ms)</b>	If the PDS-8x1 controller does not receive any data from a client PC within the period of the "Connection WDT timeout", the module will close the connection to the client. 0 = Disabled, Min. setting value = 10000	0 (Disabled)
<b>Network WDT timeout (System Timeout) (ms)</b>	If the PDS-8x1 controller does not receive any data from any of the clients within the period of the "Network WDT timeout", the module will reboot itself.  This setting is the same as "SystemTimeout" setting (unit: ms) on Console/Telnet command, and is the same as "/STxxx" in command line parameter (unit: seconds).	0 (Disabled)

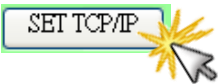

	<p>When user uses “config=RESET” Console/Telnet command to clear the EEPROM, the “Network WDT timeout” (SystemTimeout, /ST) setting will also be cleared to 0.</p> <p>Users have to configure this setting again by “SystemTimeout” Console/Telnet command.</p> <p>0 = Disabled, Min. setting value = 30000</p>	
<p><b>Master IP</b></p>	<p>If the Master IP is set, only the client using Master IP can change the COM Port configuration. It is to prevent the COM Port configuration changed by other clients.</p>	<p>empty</p>
<p><b>Reset System</b></p>	<p>If the “<b>Reset System</b>” option is checked, the PDS-8x1 controller will reboot itself after the saving operation is complete, otherwise the original settings will still be valid until the next power-on.</p> <div style="background-color: #e0ffe0; padding: 5px; border: 1px solid #000;"> <p><input checked="" type="checkbox"/> <b>Reset System</b>  <b>IP/MASK/GATEWAY changes only take effect after the system is rebooted</b></p> </div>	
<p><b>SET TCP/IP</b></p>	<p>Click this button to save the revised settings to the PDS-8x1 controller.</p> <div style="text-align: center;">  </div>	

## 4.2.1 IP Filter Setting

The IP filter setting limits which client PCs are able to link to the PDS-8x1 controller via specific IP addresses. When one or more IP addresses are set in the filter table, only client PCs where the IP address is included in the range listed of the filter table will be able to connect to the PDS-8x1 controller. Any requests from other PCs will be rejected.

**Reset System**  
 IP/MASK/GATEWAY changes only take effect after the system is rebooted

**Set IP Filter** **PDS-821:1-00 Ip Filter Setup Page**

IP1 + IP2 or IP1 + MASK	Current	New
IP1 IP2/MASK	..... .....	<input type="text"/> <input type="text"/>
IP1 IP2/MASK	..... .....	<input type="text"/> <input type="text"/>
IP1 IP2/MASK	..... .....	<input type="text"/> <input type="text"/>
IP1 IP2/MASK	..... .....	<input type="text"/> <input type="text"/>
IP1 IP2/MASK	..... .....	<input type="text"/> <input type="text"/>
IP1 IP2/MASK	..... .....	<input type="text"/> <input type="text"/>
IP1 IP2/MASK	..... .....	<input type="text"/> <input type="text"/>
IP1 IP2/MASK	..... .....	<input type="text"/> <input type="text"/>
IP1 IP2/MASK	..... .....	<input type="text"/> <input type="text"/>
IP1 IP2/MASK	..... .....	<input type="text"/> <input type="text"/>
IP1 IP2/MASK	..... .....	<input type="text"/> <input type="text"/>

Save to EEPROM  
 Reload from EEPROM  
 Apply the current settings

The following is an overview of the parameters contained in the IP Filter Setup Page section:

Item	Description																
<p><b>Set IP1 only</b></p>	<p>Set a single IP address, the IP address entered in the “<b>IP1</b>” and “<b>IP2/MASK</b>” text fields will be the same, as the image below shows. Only clients who’s IP address is included in the filter table are able to connect to the PDS-8x1 controller.</p> <table border="1" data-bbox="502 526 1404 660"> <thead> <tr> <th>IP1 + IP2 or IP1 + MASK</th> <th>Current</th> <th>New</th> </tr> </thead> <tbody> <tr> <td>IP1</td> <td>----</td> <td>10.0.9.5</td> </tr> <tr> <td>IP2/MASK</td> <td>----</td> <td>10.0.9.5</td> </tr> <tr> <td>IP1</td> <td>----</td> <td></td> </tr> </tbody> </table>	IP1 + IP2 or IP1 + MASK	Current	New	IP1	----	10.0.9.5	IP2/MASK	----	10.0.9.5	IP1	----					
IP1 + IP2 or IP1 + MASK	Current	New															
IP1	----	10.0.9.5															
IP2/MASK	----	10.0.9.5															
IP1	----																
<p><b>Set IP1 + IP2</b></p>	<p>Set a range of IP address as a starting and ending point. The initial IP address must be entered in the “<b>IP1</b>” text field and final IP address must be entered in the “<b>IP2/MASK</b>” text field, as the image below shows.</p> <table border="1" data-bbox="502 862 1404 996"> <thead> <tr> <th>IP1 + IP2 or IP1 + MASK</th> <th>Current</th> <th>New</th> </tr> </thead> <tbody> <tr> <td>IP1</td> <td>----</td> <td>10.0.9.5</td> </tr> <tr> <td>IP2/MASK</td> <td>----</td> <td>10.0.9.55</td> </tr> <tr> <td>IP1</td> <td>----</td> <td></td> </tr> </tbody> </table> <p>This allows clients who’s IP address is included in the range of <b>10.0.9.5 to 10.0.9.55</b> are able to connect to the PDS-8x1 controller.</p>	IP1 + IP2 or IP1 + MASK	Current	New	IP1	----	10.0.9.5	IP2/MASK	----	10.0.9.55	IP1	----					
IP1 + IP2 or IP1 + MASK	Current	New															
IP1	----	10.0.9.5															
IP2/MASK	----	10.0.9.55															
IP1	----																
<p><b>Set IP1 + Mask</b></p>	<p>Set the IP Filter (Available IP) range, the IP address must be entered in the “<b>IP1</b>” text field and Mask address must be entered in the “<b>IP2/MASK</b>” text field, as the image below shows.</p> <table border="1" data-bbox="502 1265 1404 1422"> <thead> <tr> <th>IP1 + IP2 or IP1 + MASK</th> <th>Current</th> <th>New</th> </tr> </thead> <tbody> <tr> <td>IP1</td> <td>----</td> <td>10.0.9.5</td> </tr> <tr> <td>IP2/MASK</td> <td>----</td> <td>255.255.255.0</td> </tr> <tr> <td>IP1</td> <td>----</td> <td></td> </tr> </tbody> </table> <p>This allows clients who’s IP address is included in the range of <b>10.0.9.0 to 10.0.9.255</b> are able to connect to the PDS-8x1 controller.</p> <p><b>Note that how to get the IP address range 10.0.9.0 to 10.0.9.255? It’s calculated as follows:</b></p> <table border="1" data-bbox="502 1668 1404 1713"> <tr> <td><b>Formula: (IP1 &amp; MASK) to (IP1 &amp; Mask) + (~MASK)</b></td> </tr> </table> <p style="text-align: center;">↓</p> <table border="1" data-bbox="502 1758 1404 1803"> <tr> <td><b>(10.0.9.5 &amp; 255.255.255.0) to (10.0.9.5 &amp; 255.255.255.0) + (0.0.0.255)</b></td> </tr> </table> <p style="text-align: center;">↓</p> <table border="1" data-bbox="502 1848 1404 1892"> <tr> <td><b>(10.0.9.0) to (10.0.9.0) + (0.0.0.255)</b></td> </tr> </table> <p style="text-align: center;">↓</p> <table border="1" data-bbox="502 1937 1404 1982"> <tr> <td><b>10.0.9.0 to 10.0.9.255</b></td> </tr> </table>	IP1 + IP2 or IP1 + MASK	Current	New	IP1	----	10.0.9.5	IP2/MASK	----	255.255.255.0	IP1	----		<b>Formula: (IP1 &amp; MASK) to (IP1 &amp; Mask) + (~MASK)</b>	<b>(10.0.9.5 &amp; 255.255.255.0) to (10.0.9.5 &amp; 255.255.255.0) + (0.0.0.255)</b>	<b>(10.0.9.0) to (10.0.9.0) + (0.0.0.255)</b>	<b>10.0.9.0 to 10.0.9.255</b>
IP1 + IP2 or IP1 + MASK	Current	New															
IP1	----	10.0.9.5															
IP2/MASK	----	255.255.255.0															
IP1	----																
<b>Formula: (IP1 &amp; MASK) to (IP1 &amp; Mask) + (~MASK)</b>																	
<b>(10.0.9.5 &amp; 255.255.255.0) to (10.0.9.5 &amp; 255.255.255.0) + (0.0.0.255)</b>																	
<b>(10.0.9.0) to (10.0.9.0) + (0.0.0.255)</b>																	
<b>10.0.9.0 to 10.0.9.255</b>																	

<b>Save to EEPROM</b>	If the <b>“UPDATE”</b> button is clicked with checking <b>“Save to EEPROM”</b> option, the new settings will be saved to the PDS-8x1 controller only and the new settings will be valid after the next power-on.
<b>Reload from EEPROM</b>	If the <b>“UPDATE”</b> button is clicked with checking <b>“Reload from EEPROM”</b> option, PDS-8x1 controller can apply the settings from EEPROM immediately.
<b>Apply the current settings</b>	If the <b>“Apply the current settings”</b> checked when the <b>“UPDATE”</b> button is clicked, the new settings will be valid immediately.
<b>UPDATE</b>	Click this button to save the revised settings to the PDS-8x1 controller.



Note: After configuring IP filter settings, please confirm that the “Save to EEPROM” and “Apply the current settings” option are checked, and then click the “UPDATE” button.

Save to EEPROM  
 Reload from EEPROM  
 Apply the current settings

## 4.3 COM Port Settings

The COM Port Settings section provides functions allowing items such as baud rate, data format, data transmission mode and pair-connection settings, etc. to be configured.

**PDS-821:1-00 COM PORT Setup Page**

**COM Port Settings [saved in EEPROM]**  
COM 1: 9600, 8, N, 1, FTL=0, DBDT=0:0, EndChar=00, M0, ST=100, MAT=0

**Currently Used COM Port Settings**  
COM 1: 9600, 8, N, 1, FTL=1, DBDT=0:3, EndChar=00, M0, ST=200, MAT=0

**Configure COM PORT**

Port (COM0 for ALL PORTS)	COM 1 ▼
Baud Rate	9600 ▼
Data Bits	8 ▼
Parity	None ▼
Stop Bits	1 ▼
Rx FIFO Trigger Level	1 ▼
Data Buffered Delay Time(DBDT)	<input type="text"/> ms
End Char	<input type="text"/> (hex)
Operation Mode	<input type="radio"/> M0 (Transparent Mode) <input type="radio"/> M1 (Slave Mode) <input type="radio"/> M2 (Half-Slave Mode)
Slave Timeout	<input type="text"/> ms
Master Ack Timeout(MAT)	<input type="text"/> ms, 0:DISABLE
<input checked="" type="checkbox"/> Save current settings to EEPROM	
<input checked="" type="checkbox"/> Apply current settings	

SET COM PORT

[Set Remote VCOM3 connection](#)

- The COM Port Settings list is saved in the EEPROM on the PDS-8x1 controller.

<b>COM Port Settings [saved in EEPROM]</b>
COM 1: 9600, 8, N, 1. FTL=0, DBDT=0:0, EndChar=00, M0, ST=100, MAT=0

- The Currently Used COM Port Settings list.

<b>Currently Used COM Port Settings</b>
COM 1: 9600, 8, N, 1. FTL=1, DBDT=0:3, EndChar=00, M0, ST=200, MAT=0

- The COM Port Settings area.

<b>Configure COM PORT</b>	
Port (COM0 for ALL PORTS)	COM 1 ▼
Baud Rate	9600 ▼
Data Bits	8 ▼
Parity	None ▼
Stop Bits	1 ▼
Rx FIFO Trigger Level	1 ▼
Data Buffered Delay Time(DBDT)	<input type="text"/> ms
End Char	<input type="text"/> (hex)
Operation Mode	<input type="radio"/> M0 (Transparent Mode) <input type="radio"/> M1 (Slave Mode) <input type="radio"/> M2 (Half-Slave Mode)
Slave Timeout	<input type="text"/> ms
Master Ack Timeout(MAT)	<input type="text"/> ms, 0:DISABLE
<input checked="" type="checkbox"/> Save current settings to EEPROM <input checked="" type="checkbox"/> Apply current settings	
<input type="button" value="SET COM PORT"/>	

The following is an overview of the parameters contained in the COM Port Settings section:

Item	Description	Default
<b>Port (COM0 for ALL PORTS)</b>	The COM Port number on the PDS-8x1 controller.	COM1
<b>Baud Rate</b>	This parameter is used to set the Baud Rate for the COM ports.	9600
<b>Data Bits</b>	This parameter is used to set the Data Size for the COM ports.	8
<b>Parity</b>	This parameter is used to set the Parity for the COM ports.	None
<b>Stop Bits</b>	This parameter is used to set the Stop Bits for the COM ports.	1
<b>Rx FIFO Trigger Level</b>	This option is used to set the number of characters that the COM Port can receive at once time, the PDS-8x1 controller will move the data from the COM Port FIFO to the PDS-8x1 controller. If the amount of data transferred is large and uses a transfer speed (115200 bps), setting a smaller value is helpful in preventing data loss.	1
<b>Data Buffered Delay Time (DBDT)</b>	When the COM port does not receive data from devices connected over the period of DBDT setting, the PDS-8x1 controller will determine that the data transfer is over and return to process next tasks.	0
<b>End Char</b>	The PDS-8x1 controller outputs an Ethernet packet immediately after the ending-chars pattern is identified from the incoming serial data.	0 (Disabled)
<b>Operation Mode</b>	<p>M0: Transparent Mode (Multi-echo mode)                      M1: Slave Mode (Single-echo mode)                      M2: Half-Slave Mode (Is situated between M0 and the M1 mode)</p> <p>The more detailed information regarding M0, M1 and M2 modes, please refer to the <a href="#">Section 4.3.1 "Operation Mode"</a>.</p>	M0

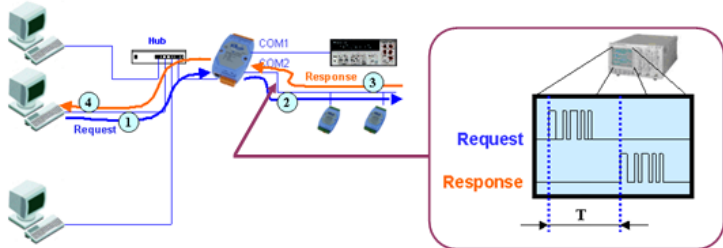
<p><b>Slave Timeout</b></p>	<p>In M1 (Slave Mode), the slave mode timeout setting is use to set the waiting time after last character of the request sent to the device. If the device does not respond within the timeout value, the PDS-8x1 controller will return a timeout error and process next request.</p> 	<p>200 ms</p>
<p><b>Master ACK timeout (MAT)</b></p>	<p>If the PDS-8x1 controller does not receive any data from Slave for a certain period, the PDS-8x1 controller will return an ACK character to Master and process next request based on the configured timeout value.</p>	<p>0 (Disabled)</p>
<p><b>Save current settings to EEPROM</b></p>	<p>If the <b>“SET COM PORT”</b> button is clicked with checking <b>“Save current settings to EEPROM”</b> option, the new settings will be saved to the PDS-8x1 controller only and the new settings will be valid after the next power-on.</p>	
<p><b>Apply current settings</b></p>	<p>If the <b>“Apply current settings”</b> checked when the <b>“SET COM PORT”</b> button is clicked, the new settings will be valid immediately.</p>	
<p><b>SET COM PORT</b></p>	<p>Click this button to save the revised settings to the PDS-8x1 controller.</p>	



Note: After configuring IP filter settings, please confirm that the “Save current settings to EEPROM” and “Apply current settings” option are checked, and then click the “SET COM PORT” button.

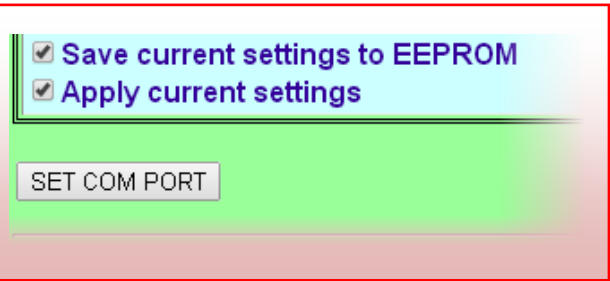



### 4.3.1 Operation Mode: M0, M1 and M2

➤ **M0: Transparent Mode (Multi-echo mode)**

**Condition 1:** One client sends a request to the PDS-8x1 controller to access each device. The PDS-8x1 controller echoes the data from each device to each connected client.

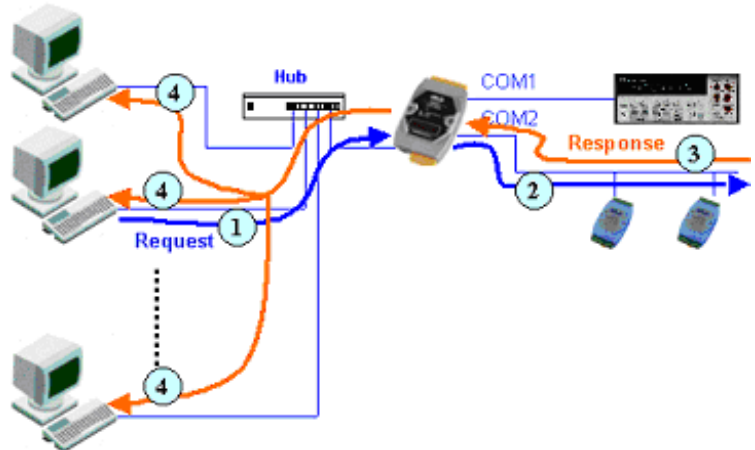

**Condition 2:** No clients send any requests to the PDS-8x1 controller. The PDS-8x1 controller echoes data from the devices to each connected client.

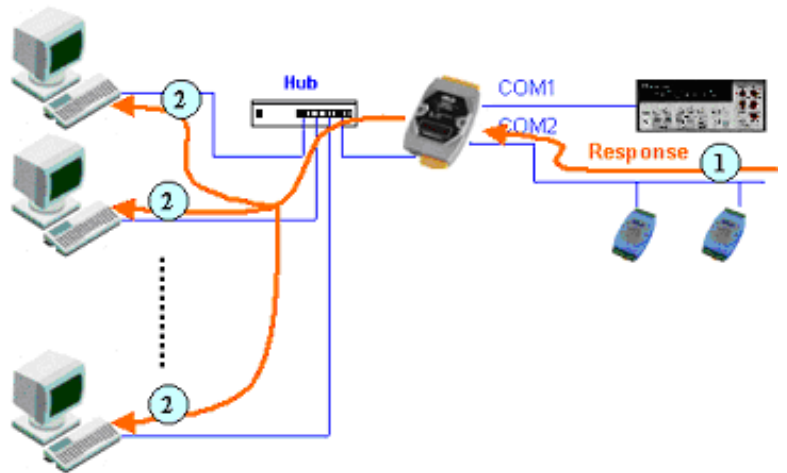

➤ **M1: Slave Mode (Single-echo mode)**

**Condition 1:** One client sends a request to the PDS-8x1 controller to access the other devices. The PDS-8x1 controller echoes data from the devices to the client that requested the service.

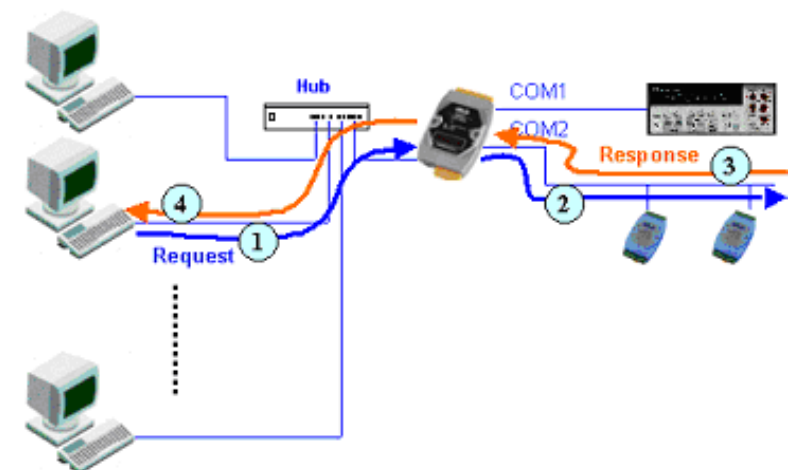

**Condition 2:** No clients send any requests to the PDS-8x1 controller. The PDS-8x1 controller doesn't echo any data from the devices to any client.

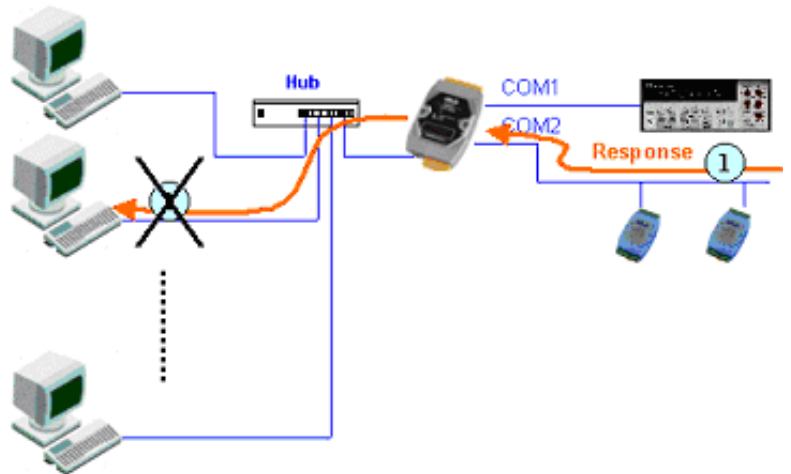

➤ **M2: Half-Slave Mode (Is situated between M0 and the M1 mode)**

If only one client connects to the PDS-8x1 controller, the operation mode same as M0 mode, please refer to page 48 (**M0: Transparent Mode**); and if there are two or more clients connecting to the PDS-8x1 controller, the operation mode same as M1 mode please refer to page 49 (**M1: Slave Mode**).

### 4.3.2 Set Remote VCOM3 Connection

The “Set Remote VCOM3 Connection” section provides sets the pair-connection functions, the more detailed information regarding pair-connection applications settings, please refer to the [Section 5.3 Pair-connection Applications](#).

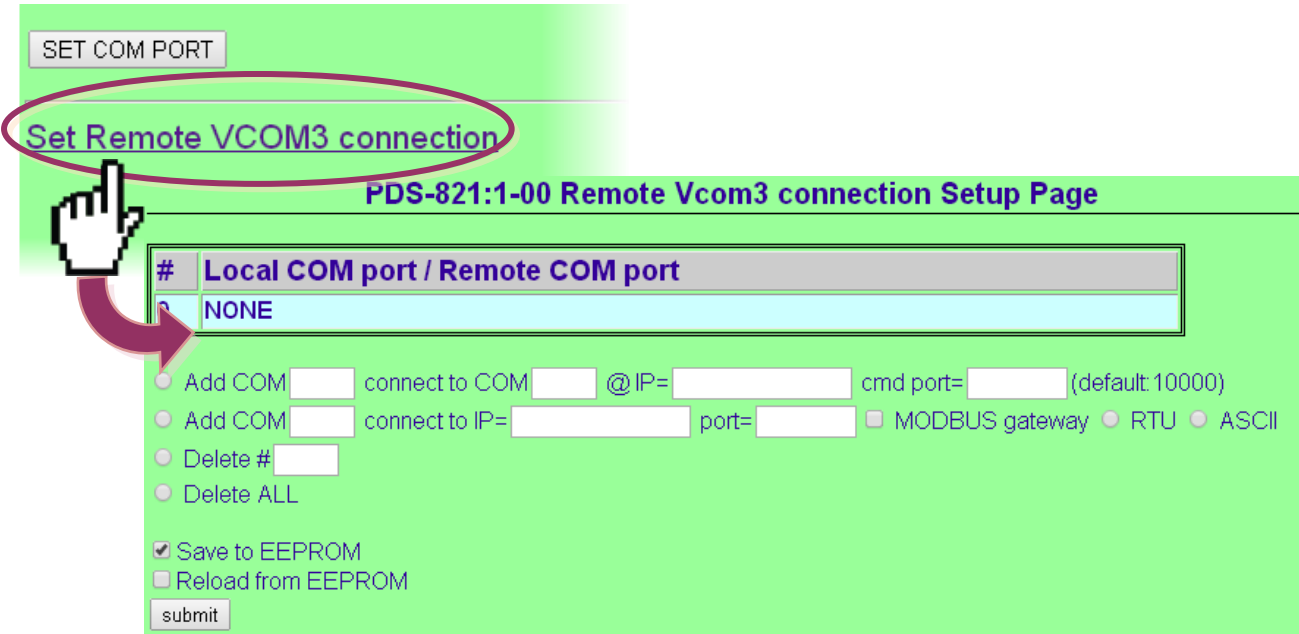

The following is an overview of the parameters contained in the Remote Vcom3 connection Setup Page section:

Item	Description
<b>Add COM “Number”</b>	Serial COM port number of the local device (Master)
<b>connect to COM “Number”</b>	Serial COM port number of the remote device (Slave)
<b>@ IP= “IP Address”</b>	IP address of the remote device (Slave)
<b>cmd port= “command port” (default: 10000)</b>	Command Port number of the remote device (Slave)
<b>Add COM “Number”</b>	Serial COM port number of the local device (Master)
<b>connect to IP= “IP Address”</b>	IP address of the remote device (Slave)
<b>Port= “TCP port”</b>	TCP Port number of the remote device (Slave)
<b>MODBUS gateway</b>	If the “MODBUS gateway” checked, the serial port is specified as gateway from the Modbus RTU or Modbus ASCII (Master) to Modbus TCP for the remote device (Slave)

Item	Description
<b>Delete # "Number"</b>	Delete a specific # "Number" from the Pair-connection List.
<b>Delete All</b>	Delete all items from the pair-connection List.
<b>Save to EEPROM</b>	If the <b>"submit"</b> button is clicked with checking <b>"Save to EEPROM"</b> option, the new settings will be saved to the PDS-8x1 controller only and the new settings will be valid after the next power-on.
<b>Reload from EEPROM</b>	If the <b>"submit"</b> button is clicked with checking <b>"Reload from EEPROM"</b> option, PDS-8x1 controller can apply the settings from EEPROM immediately.
<b>Submit</b>	Click this button to save the revised settings to the PDS-8x1 controller.



Note: After setting the pair-connection functions, please power-on reboot the PDS-8x1 controller, and then setting is complete.

## 4.4 Misc. Settings

The Miscellaneous Settings provides functions allowing items such as the alias name, Web read only, restore factory default and change password to be configured.

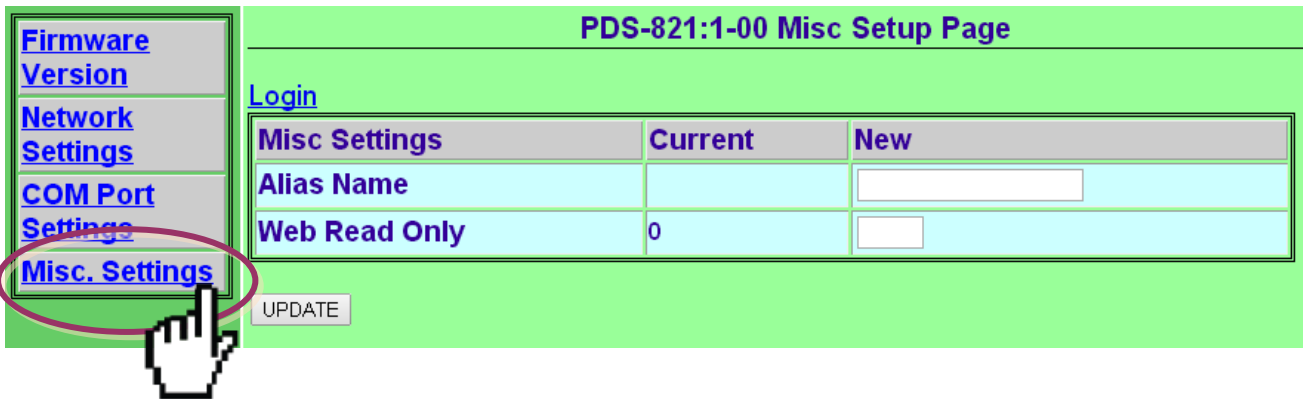

Item	Description
<b>Login</b>	Click the this tab to proceed to the Login page that can disable “Web Read Only” property, change password and Restore to Factory Default Settings, refer to the <a href="#">Sections 4.4.1 to 4.4.3</a> for more detail information.
<b>Alias Name</b>	This parameter is used to assign an alias for each PDS-8x1 controller to assist with easy identification.
<b>Web Read Only</b>	This parameter is used to enable “ <b>Web Read Only</b> ” function. If the “ <b>Web Read Only</b> ” properly is set to 1 (Enabled), the web server will <b>not</b> be able to save any new configurations to the PDS-8x1 controller. The default setting should be 0 (Disabled).  0 = Disabled, 1 = Enabled
<b>UPDATE</b>	Click this button to save the revised settings to the PDS-8x1 controller.

### 4.4.1 Disable the “Web Read Only” Function

The following instructions guide you to disable the “Web Read Only” function.

**Step 1:** Click the “Login” tab at the PDS-8x1 Misc Setup Page to proceed to the Login Page.

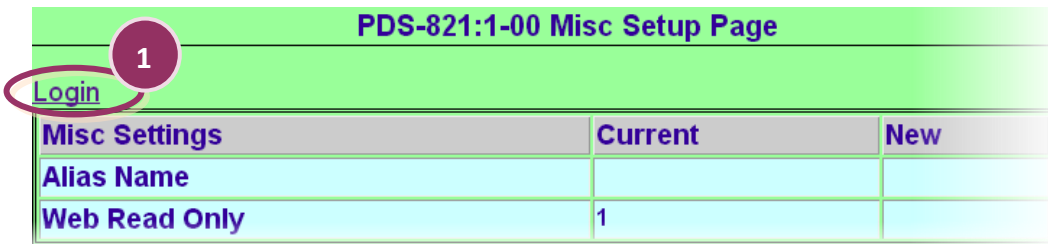

**Step 2:** Enter the password in the “PASSWORD:” field (use the default password “admin”) and click the “LOGIN” button to proceed to the settings page. If you want to change default password, please refer to [Section 4.4.2 Change Password](#).

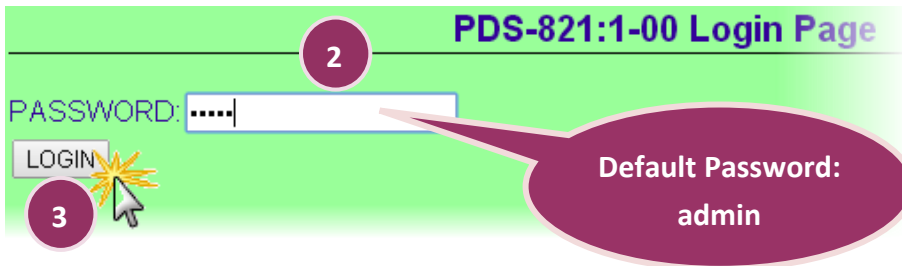

**Step 3:** Set the new “Web Read Only” properly = 0 and click the “UPDATE” button to update the settings.

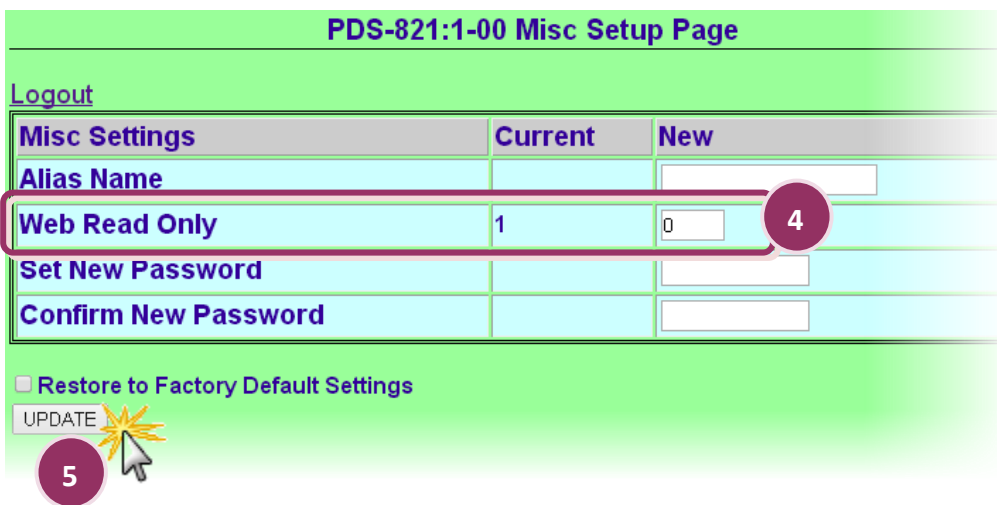

**Step 4:** Check that the current the “**Web Read Only**” = 0 and then click “**Logout**” to complete the operation.

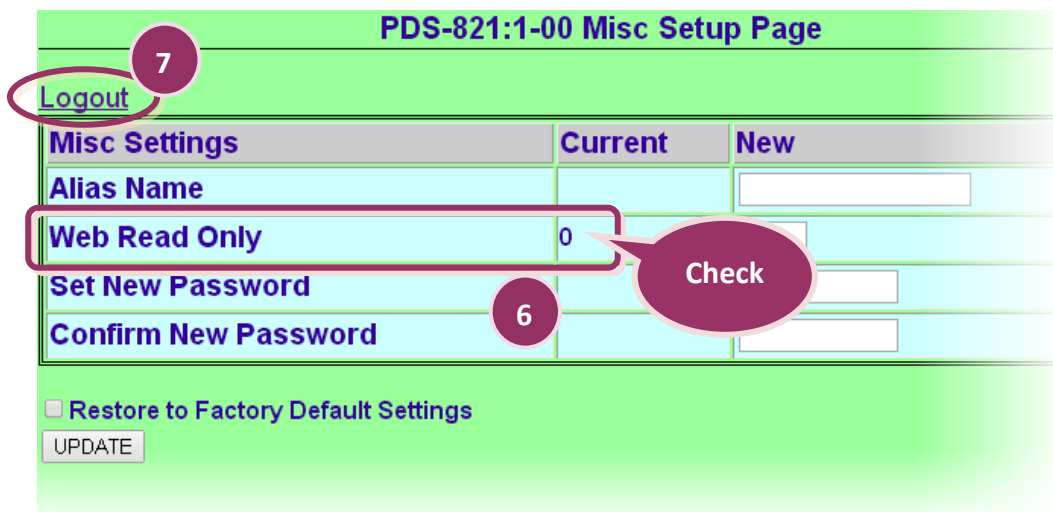

## 4.4.2 Change Password

To change a password of the Login Page, follow the procedure described below:

**Step 1:** Click the “Login” tab at the PDS-8x1 Misc Setup Page to proceed to the Login Page.

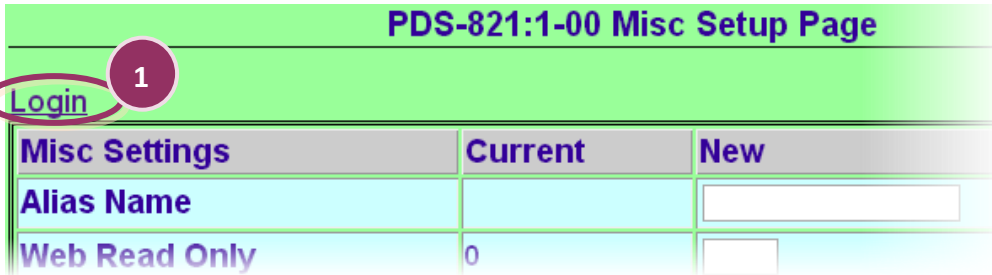

**Step 2:** Enter the password in the “PASSWORD:” field (use the default password “admin”) and click the “LOGIN” button to proceed to the settings page.

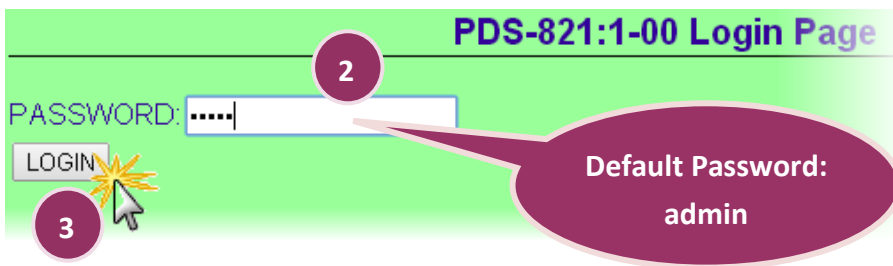

**Step 3:** Enter the new password in the “Set New Password” field. Re-enter the new password in the “Confirm new password” field.

**Step 4:** Click the “UPDATE” button to update the password, and then click the “Logout” to complete the operation.

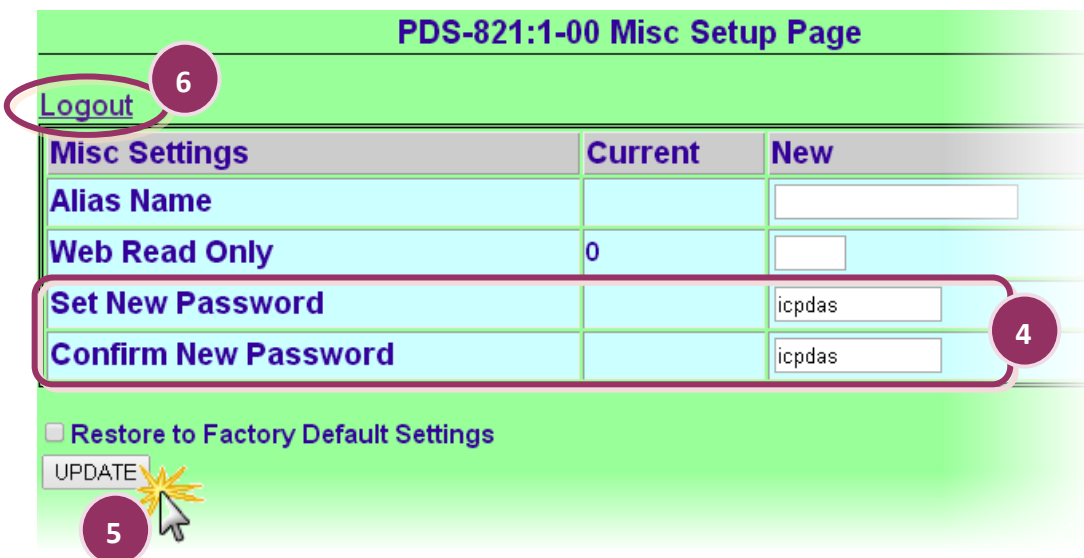



### 4.4.3 Restore to Factory Default Settings

Use the following procedure to reset all parameters to their original factory default settings:

**Step 1:** Click the “Login” tab at the PDS-8x1 Misc Setup Page to proceed to the Login Page.

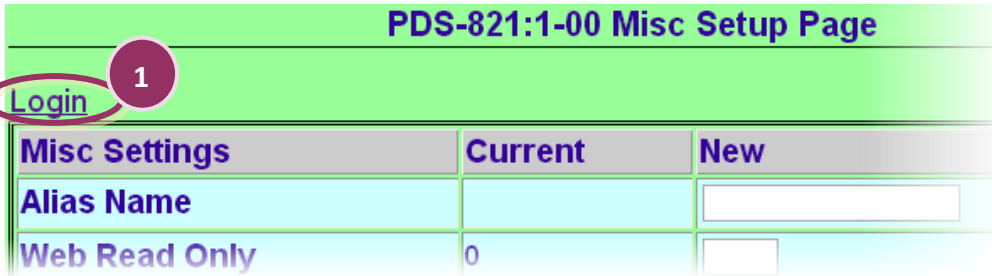

**Step 2:** Enter the password in the “PASSWORD:” field (use the default password “admin”) and click the “LOGIN” button to proceed to the settings page. If you want to change default password, please refer to [Section 4.4.2 Change Password](#).

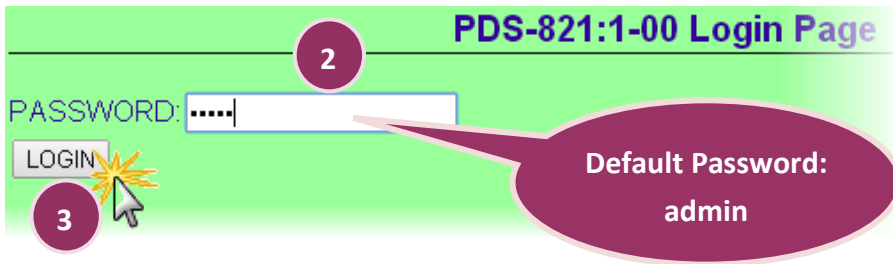

**Step 3:** Check the “Restore to Factory Default Settings” option and click the “UPDATE” button to update the setting.

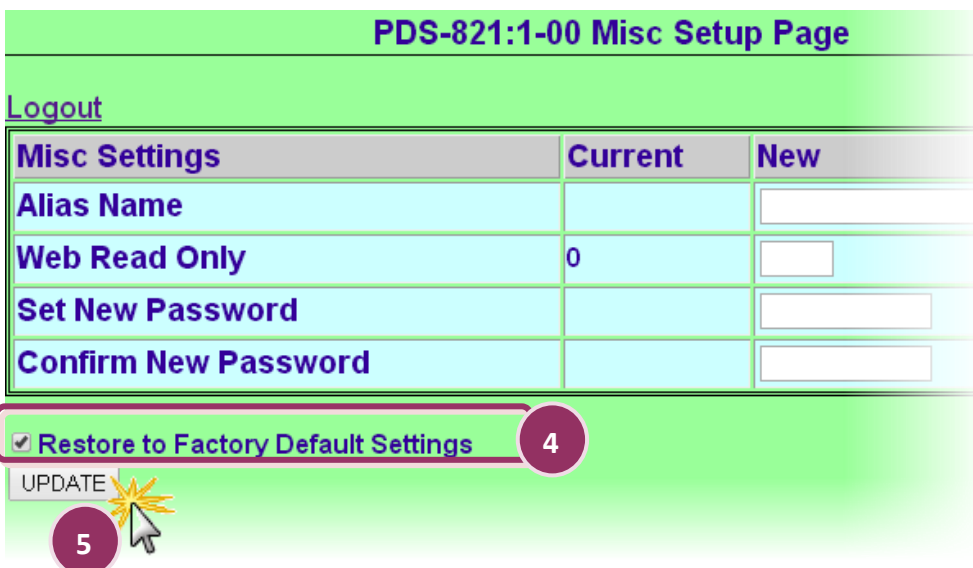

**Step 4:** Click the “Logout” to complete the operation, and then **power-on reboot** the PDS-8x1 controller.

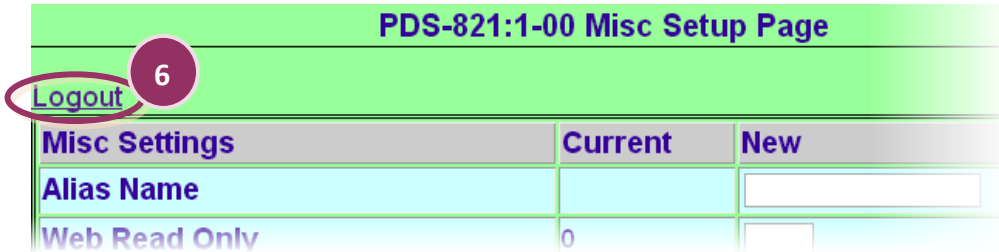

The following is an overview of the factory default settings:

Factory Default Settings	
Network Settings	
IP Address	192.168.255.1
Gateway Address	192.168.0.1
Subnet Mask	255.255.0.0
DHCP	Disabled
Basic Settings	
Alias	N/A



**Note:**

User can restore PDS-8x1 password to default value “admin” by using “config=RESET” console command (refer to Chapter 6 Console/Telnet Commands List). This command sets most configurations of PDS-8x1 to factory setting. It requires rebooting the PDS-8x1 for loading new configuration (includes default password).

# 5. Typical Applications

## 5.1 Virtual COM Application

The PDS-8x1 controller is designed to link RS-232/422/485 devices to an Ethernet network. The VxComm utility allows the built-in PDS-8x1 COM Port to be virtualized to a standard COM Port of a host PC, as shown below:

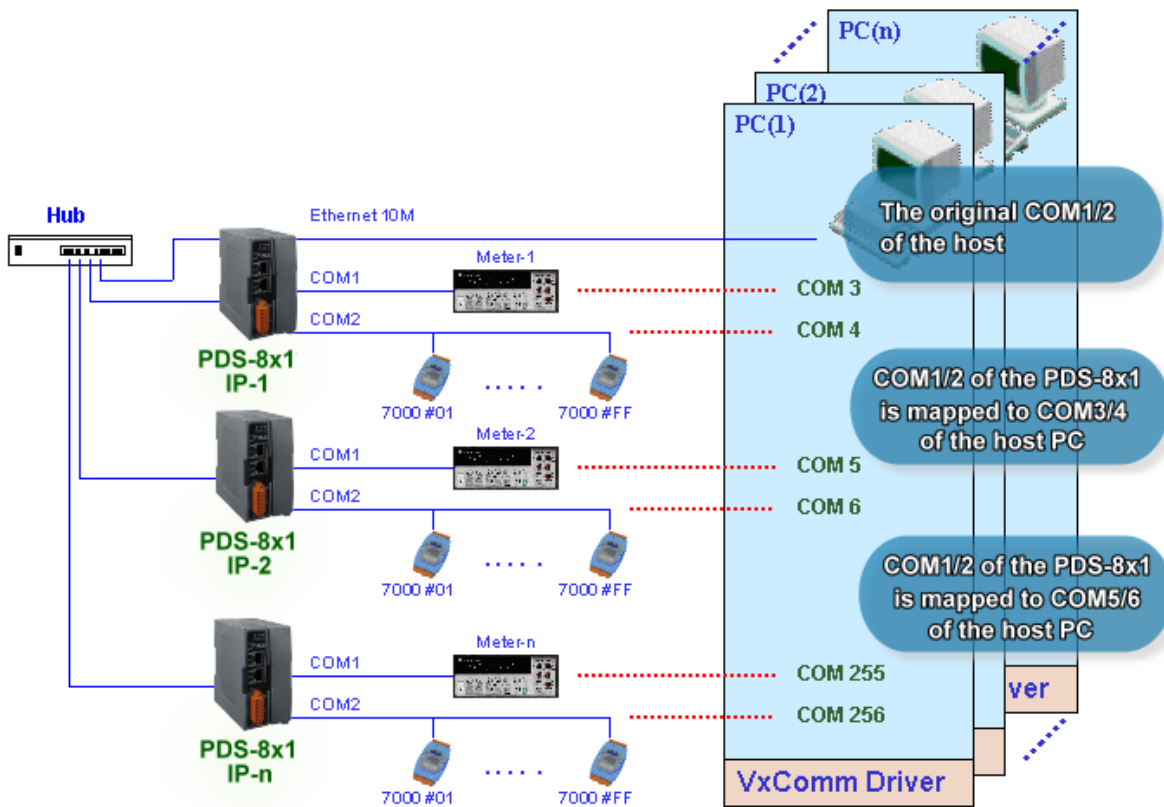

In the configuration above, Meter-1 is virtualized to link to COM3 of the host PC. Therefore, a program originally designed for the MS-COMM standard can access the meter without the need for any modification.

## 5.2 Ethernet I/O Applications

### Linking to I-7000 series modules

The I-7000 series provides a variety of I/O operations, such as D/I, D/O, A/D, D/A, Counter and Frequency Measurement, etc. The I-7000 series was originally designed to be used with RS-485 networks, so the RS-485 of COM on the PDS-8x1 can be used to link to I-7000 series modules.

By using VxComm technology, programs that support serial devices on the host PC can be upgraded from an RS-485 network to an Ethernet network without requiring any modifications to the program.

### Configurable Ethernet Data Logger

Using the VxComm driver, the PDS-8x1 + 7000 modules can be virtualized to become COM Port + 7000 modules located on the host PC, and then the Data Logger in the DCON Utility can be used to access data related to the I-7000 from the Ethernet. Signal data originating from the I-7000 modules can be analyzed using MS Excel without the need to write any custom programs.

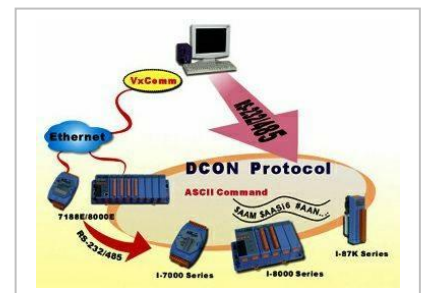

1: The DCON utility includes a log function, as show below:

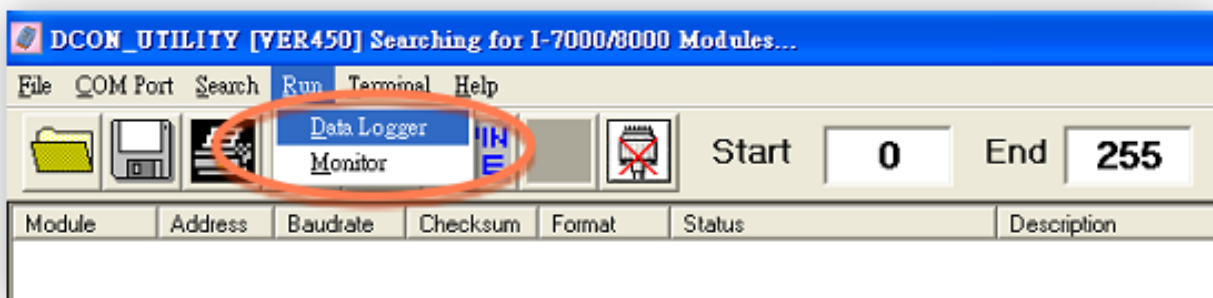

2: Configure the system connection as shown below and click the **“Start”** button to begin logging data.

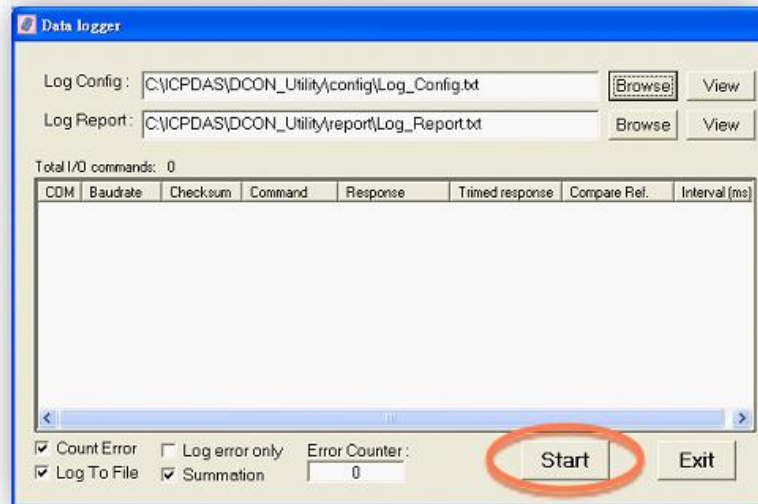

3: Open the log file in MS Excel to view the log data as shown in the example below:

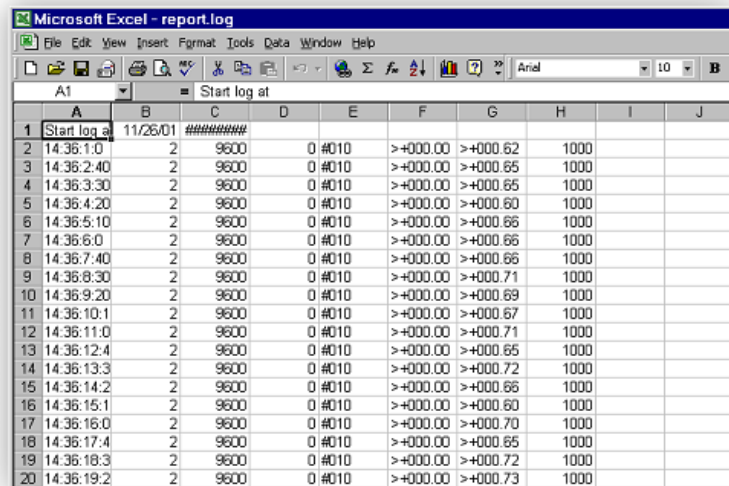

By using the I-7000 DCON utility and MS Excel in conjunction with **VxComm technology**, the signal data originating from I-7000 modules via the Ethernet network can be analyzed without the need to write custom programs. For more information about the **log function**, refer to the online help feature (English and Traditional Chinese) of the DCON utility.

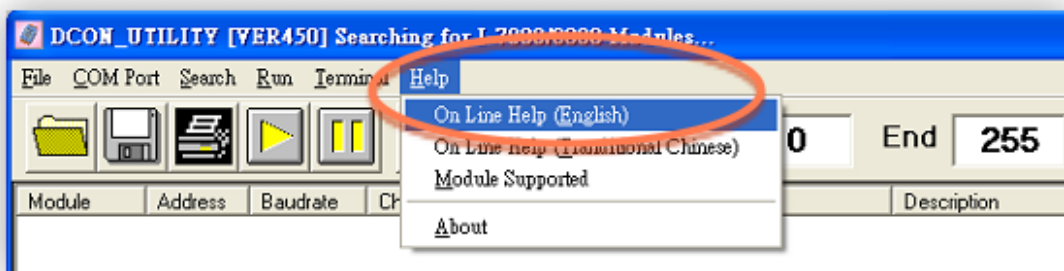

## 5.3 Pair-connection Applications

PDS-8x1 controller can be used to create a pair-connection application (as well as serial-bridge or serial-tunnel), and then route data between two serial devices via TCP/IP, which is useful when connecting mainframe computers, servers or other serial devices that do not themselves have Ethernet capability.

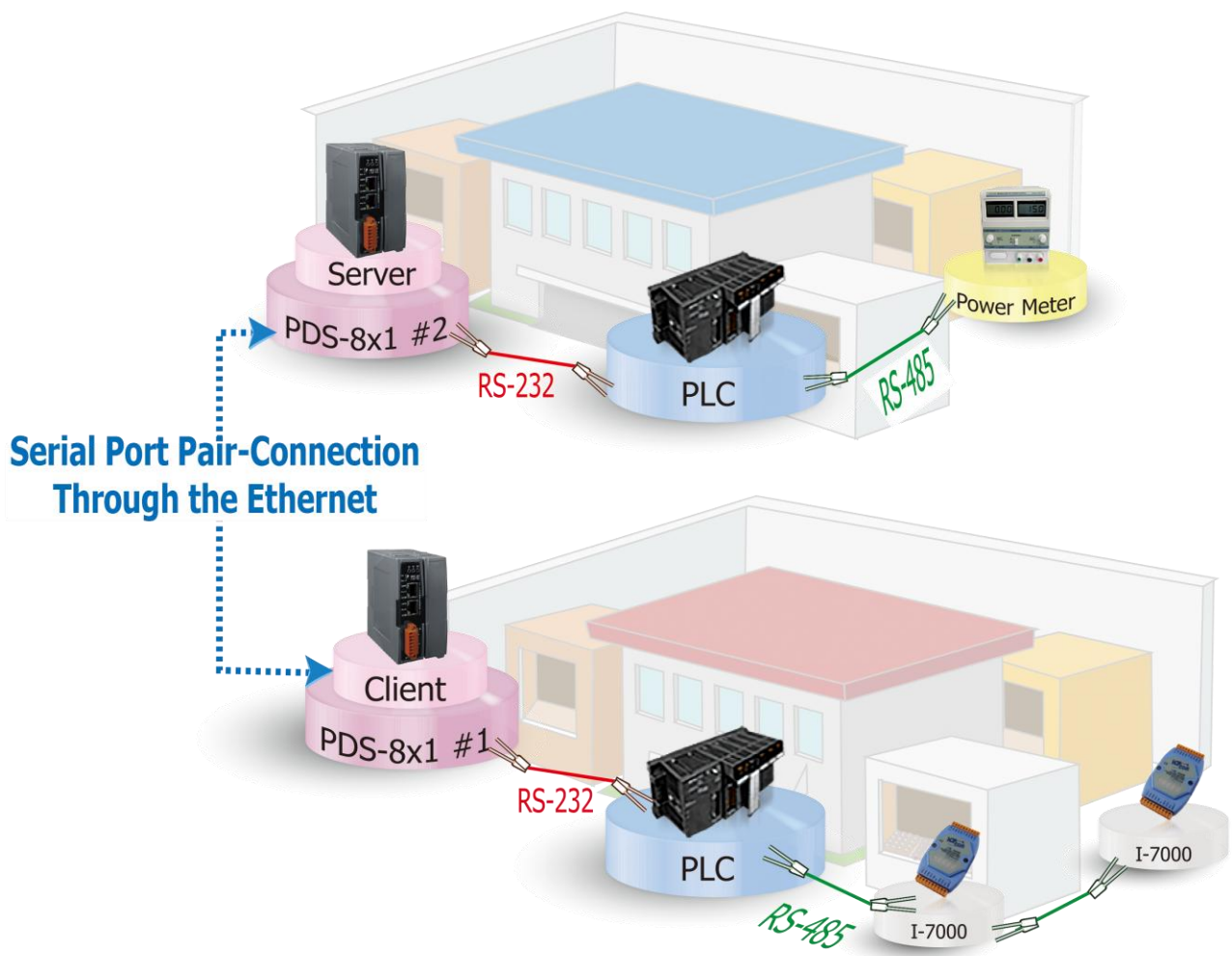

The following are examples of pair-connection tests:

**Pair-connection Settings:**

Model	Port Settings (default)			Pair-connection Settings	
	COM Port	Baud Rate	Data Format	Remote Server IP	Remote TCP Port (default)
<b>PDS-8x1 #1</b> (Client Mode)	COM1	9600	8N1	IP Address of PDS-8x1 #2	10001
<b>PDS-8x1 #2</b> (Server Mode)	COM1	9600	8N1	-	-



**Note:**

The Baud Rate and Data Format settings of the client and server (PDS-8x1 #1 and #2) depend on the COM ports of the PC (or the connected device).

Follow the procedure described below:

**Step 1: Connecting to a network, PC and Power**

1. Confirm that the PDS-8x1 controllers are functioning correctly. Refer to [Chapter 3 Setting up the PDS-8x1 controller](#) for more details.
2. Connect COM1 of the PC to COM1 of the PDS-8x1 #1, and then connect COM2 of the PC to COM1 of the PDS-8x1 #2. For detailed RS-232 wiring information, refer to [Section 2.7 “Wiring Notes for RS-232/485/422 Interfaces”](#).
3. Supply +24 V<sub>DC</sub> (+10 ~ +30 V<sub>DC</sub>) power to the PDS-8x1 controller.

※ Refer to **Figure 5-3.1** for an illustration of how to perform the above steps.

The image below shows an example of the setup for a pair-connection test:

Figure 5-3.1

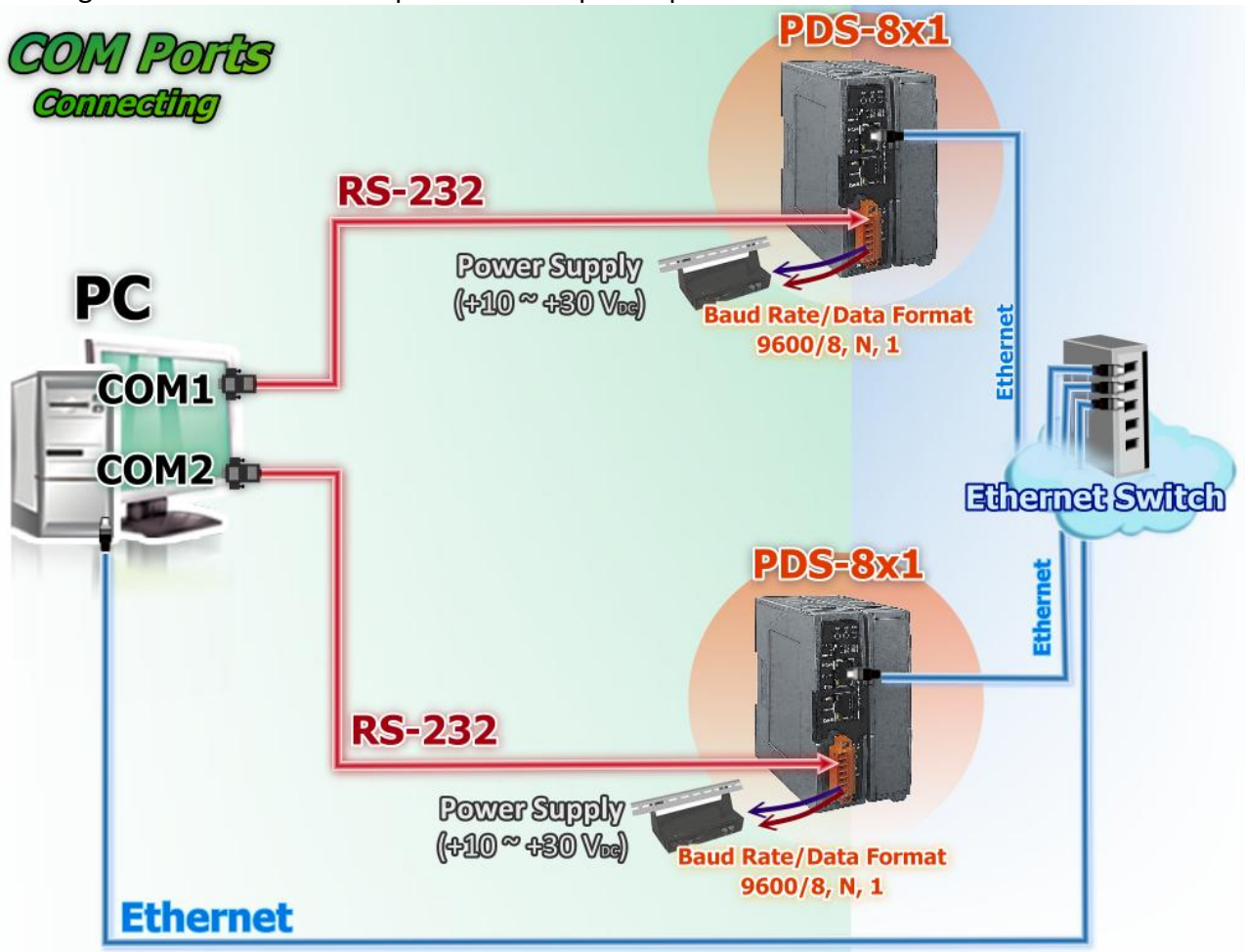

**Step 2: Configuring the Ethernet Settings**

Contact your Network Administrator to obtain the correct and functioning network configuration for the PDS-8x1 controllers (including the **IP Address, Mask and Gateway details**). Also refer to [Chapter 3 Setting up the PDS-8x1 controller](#) for more details.

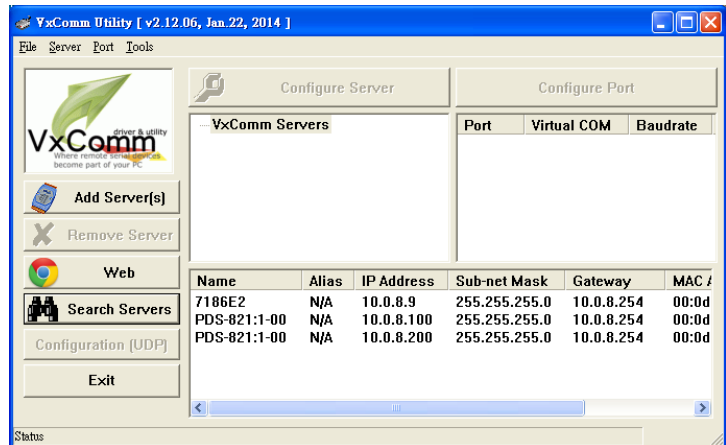

Figure 5-3.2



**Step 3: Configuring the Pair-connection (Client Mode) on the Web Server for PDS-8x1 #1**

1. Enter the URL address of the PDS-8x1 #1 in the address bar of the browser or click the **“Web”** button in the VxComm Utility to log in to the web configuration page.
2. Check **firmware version is v3.2.32[Feb 07 2014] or later** of the PDS-8x1 #1.

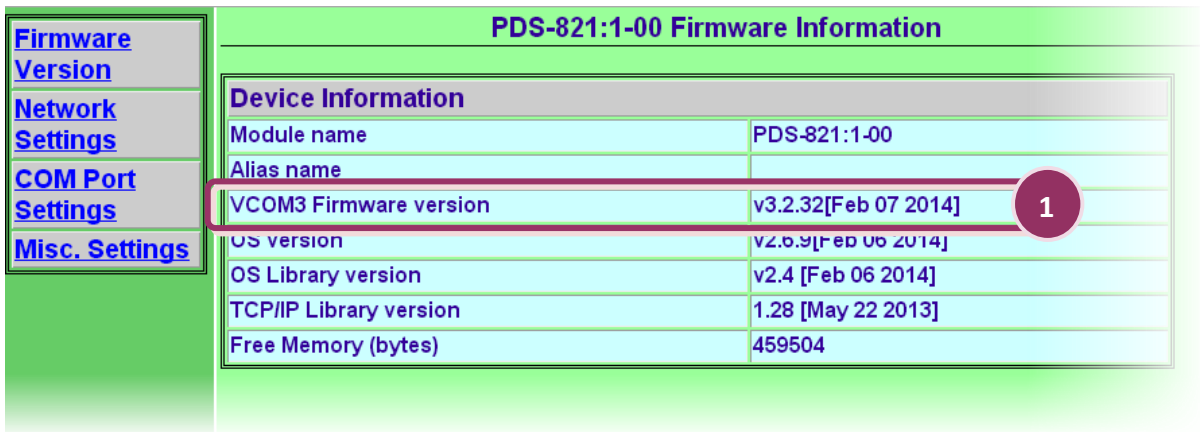

Figure 5-3.3

3. Click the **“COM Port Settings”** tag to enter the settings page, and select the appropriate **COM Port number, Baud Rate and Data Format** settings from the relevant drop down options, for example **“9600”, “8”, “None” and “1”** .

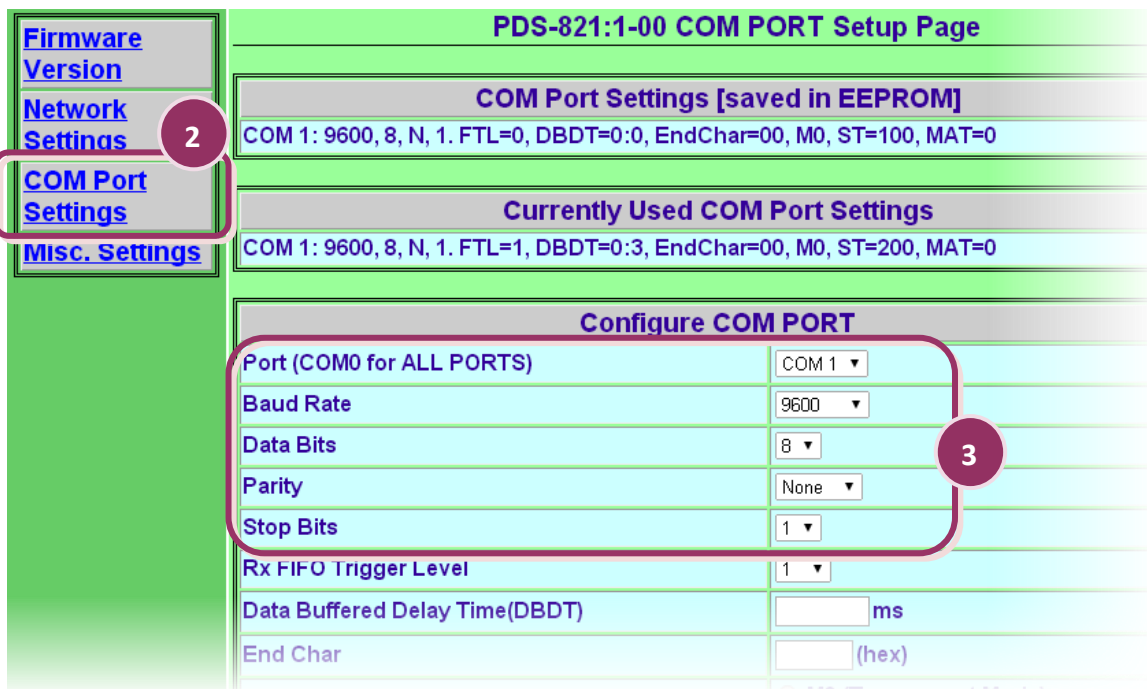

Figure 5-3.4

4. Check the **“Save current settings to EEPROM”** and **“Apply Current settings”** options, and then click the **“SET COM PORT”** button to finish configuration.
5. Click **“Set Remote VCOM3 connection”** to proceed to the PDS-8x1 Remote Vcom3 connection Setup Page (Pair-connection settings).

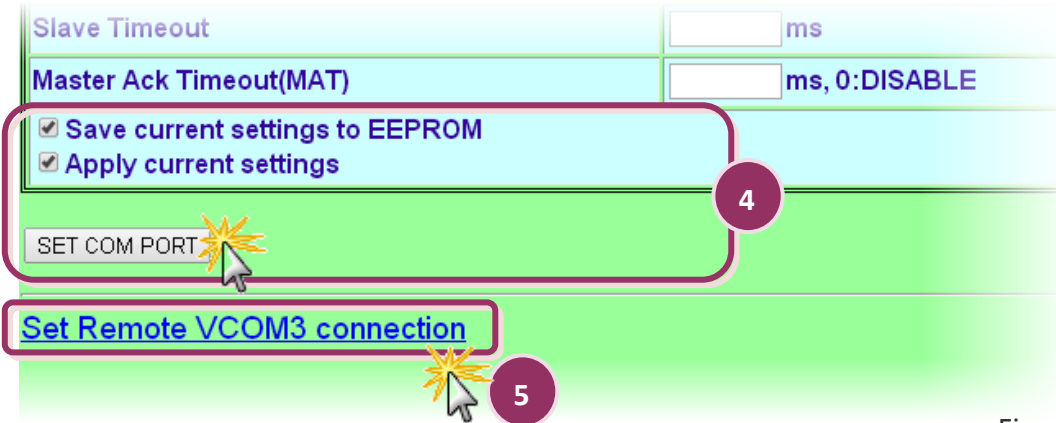

Figure 5-3.5

6. Select **“Add COM”** and type in the COM port of the PDS-8x1 #1 (Client) which you want to use. Type the appropriate **COM Port number, IP address and command port of the PDS-8x1 #2 (Server)** settings in the relevant fields, for example **“COM: 1”, “IP: 10.0.8.200” and “cmd port: 10000”**.
7. Check the **“Save to EEPROM”** option and click **“submit”** button to update configuration.

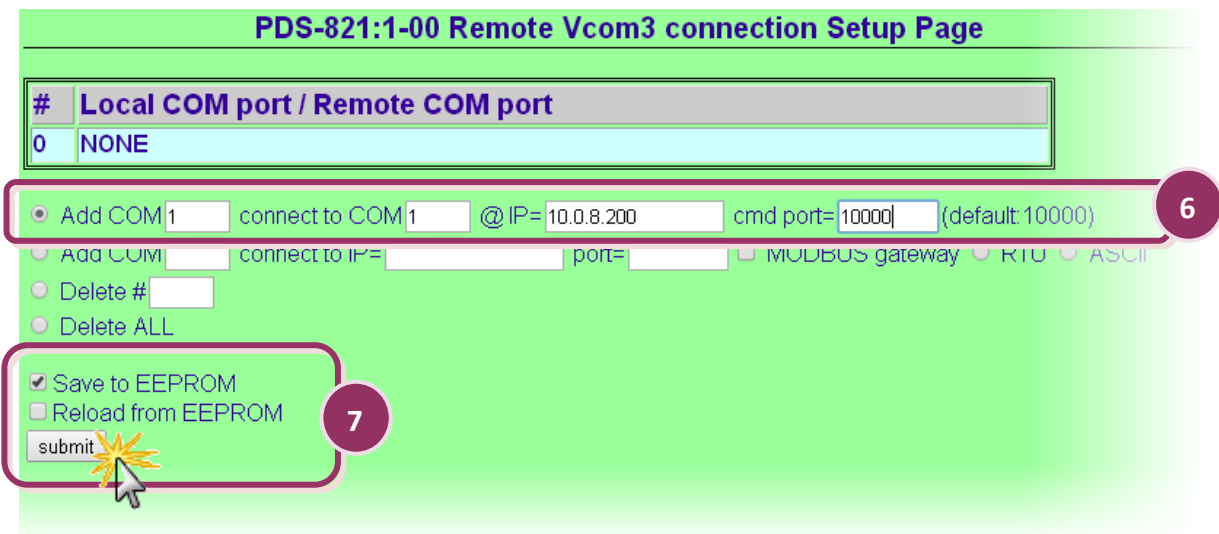

Figure 5-3.6

※ If the remote device isn't our product and doesn't support command port 10000, refer to the following to configure pair-connection function.

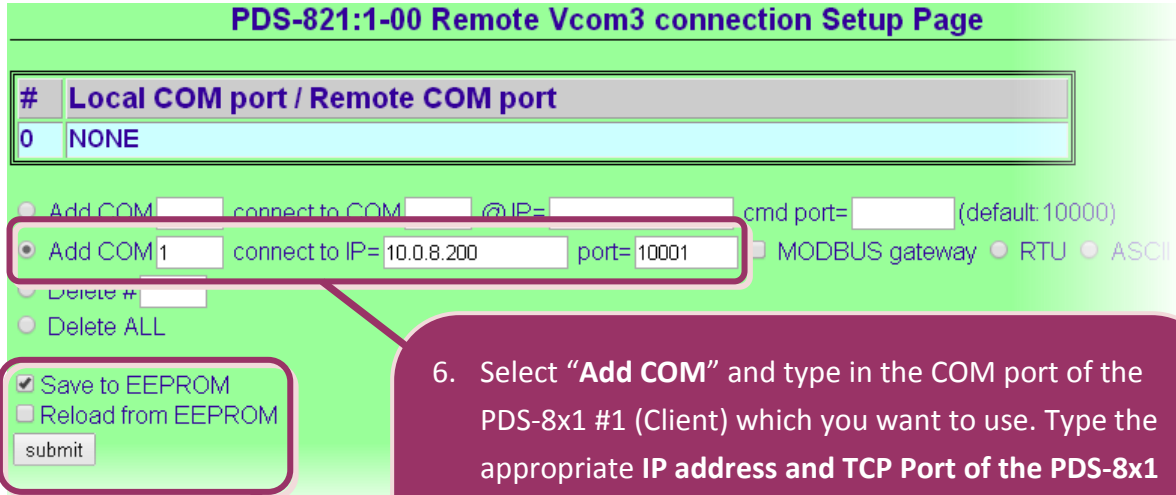

Figure 5-3.7

6. Select "Add COM" and type in the COM port of the PDS-8x1 #1 (Client) which you want to use. Type the appropriate IP address and TCP Port of the PDS-8x1 #2 (Server) settings in the relevant fields, for example "IP: 10.0.8.200" and "port: 10001".
7. Check the "Save to EEPROM" option and click "submit" button to update configuration.

8. Check the Local COM Port/Remote COM port area for pair-connection setting.
9. Reboot PDS-8x1 #1(Client) and then setting is complete.

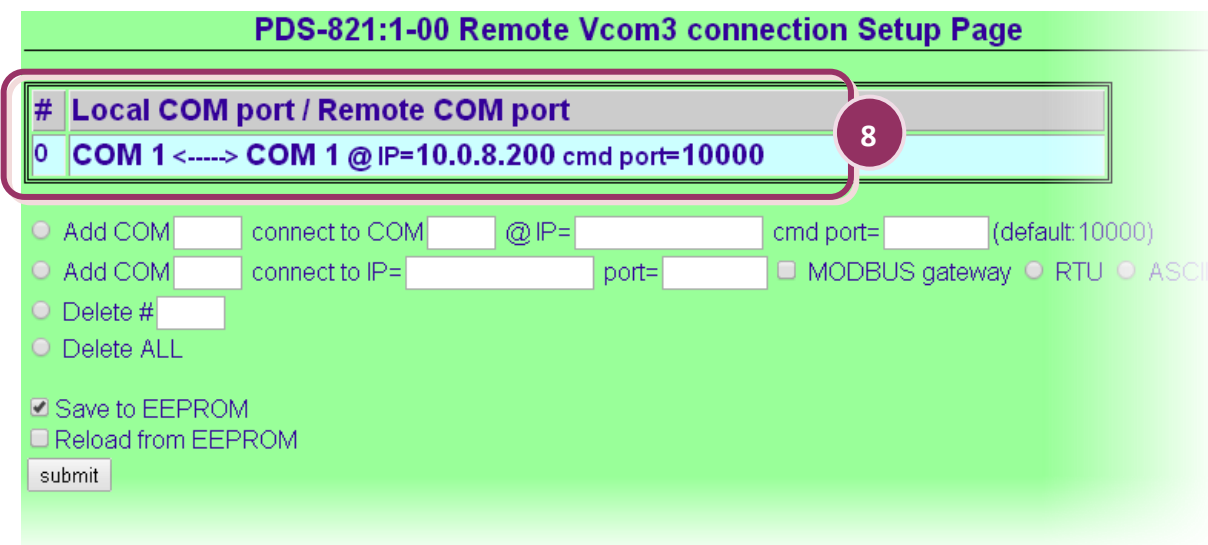

Figure 5-3.8

**Step 4: Configuring the Pair-connection (Server Mode) on the Web Server for PDS-8x1 #2**

1. Enter the URL address of the PDS-8x1 #2 in the address bar of the browser or click the **“Web”** button in the VxComm Utility to log in to the web configuration page.
2. Click the **“COM Port Settings”** tag to enter the settings page, and select the appropriate **COM Port number, Baud Rate and Data Format** settings from the relevant drop down options, for example **“9600”, “8”, “None”** and **“1”**.  
(Refer to Figure 5-3.4 for illustrations of how to perform the above step 2.)
3. Check the **“Save current settings to EEPROM”** and **“Apply Current settings”** items, and then click the **“SET COM PORT”** button to finish configuration.
4. Click **“Set Remote VCOM3 connection”** at the PDS-8x1 #2 (Server) COM PORT setup page.  
(Refer to Figure 5-3.5 for illustrations of how to perform the steps 3 and 4.)
5. Confirm that the Local COM port/Remote COM port area of the **PDS-8x1#2 (Server)** is **“None”**.

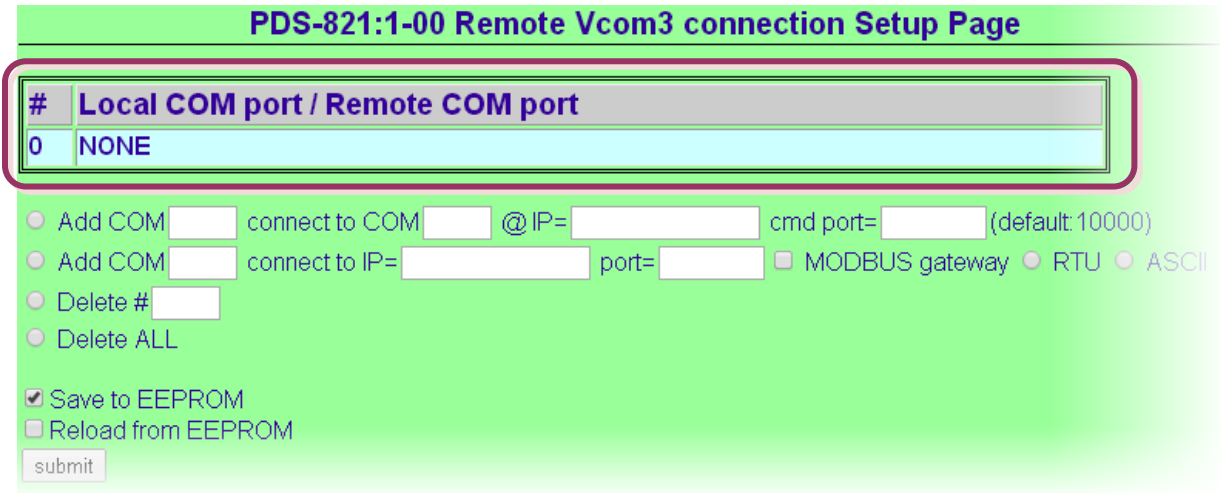

Figure 5-3.9

### Step 5: Testing the Pair-connection Functions

1. The Test2COM.exe program is located at:

CD:\Napdos\multiport\utility  
<http://ftp.icpdas.com/pub/cd/iocard/pci/napdos/multiport/utility/>



2. Execute the Test2COM.exe program.

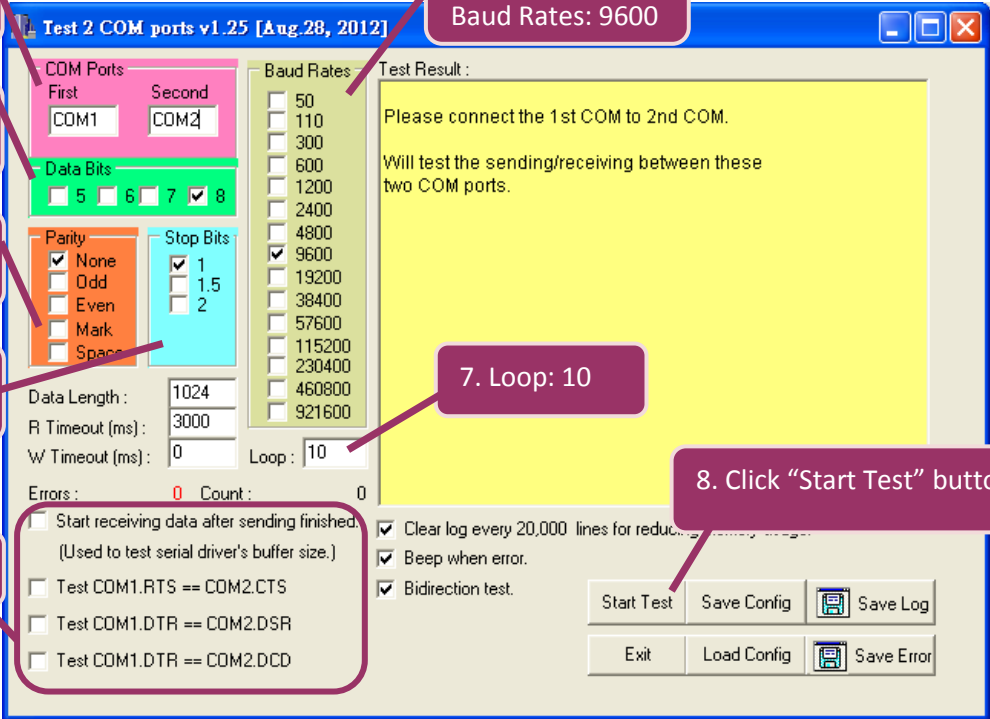

The screenshot shows the 'Test 2 COM ports v1.25' application window. Eight numbered callouts point to specific settings and actions:

- 1. Type COM1\COM2 (points to the 'First' and 'Second' COM port dropdowns)
- 2. Check Data Bits: 8 (points to the 'Data Bits' dropdown menu)
- 3. Check Parity: None (points to the 'Parity' radio button selection)
- 4. Check Stop bits: 1 (points to the 'Stop Bits' dropdown menu)
- 5. Check Baud Rates: 9600 (points to the 'Baud Rates' list)
- 6. Uncheck (points to the 'Test COM1.RTS == COM2.CTS' checkbox)
- 7. Loop: 10 (points to the 'Loop' input field)
- 8. Click "Start Test" button (points to the 'Start Test' button)

**Note:**  
The Baud Rate and data format depend on the serial port settings for the web configuration of the PDS-8x1 #1 and PDS-8x1 #2.

3. Get the test result.

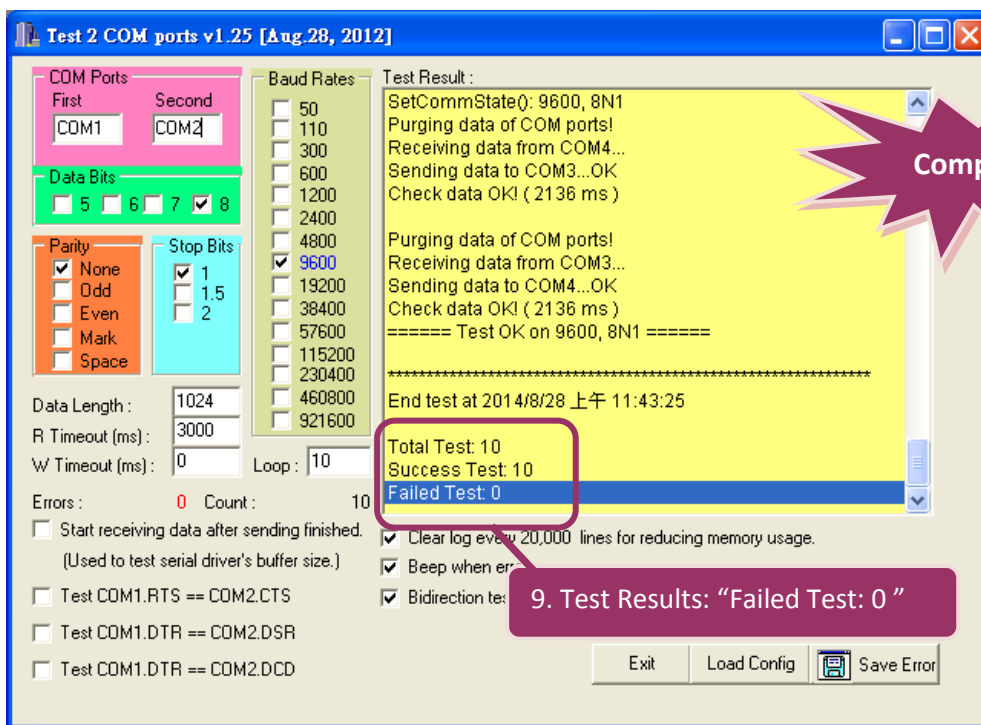

# 6. Console/Telnet Commands List

## 6.1 Operation Flowchart

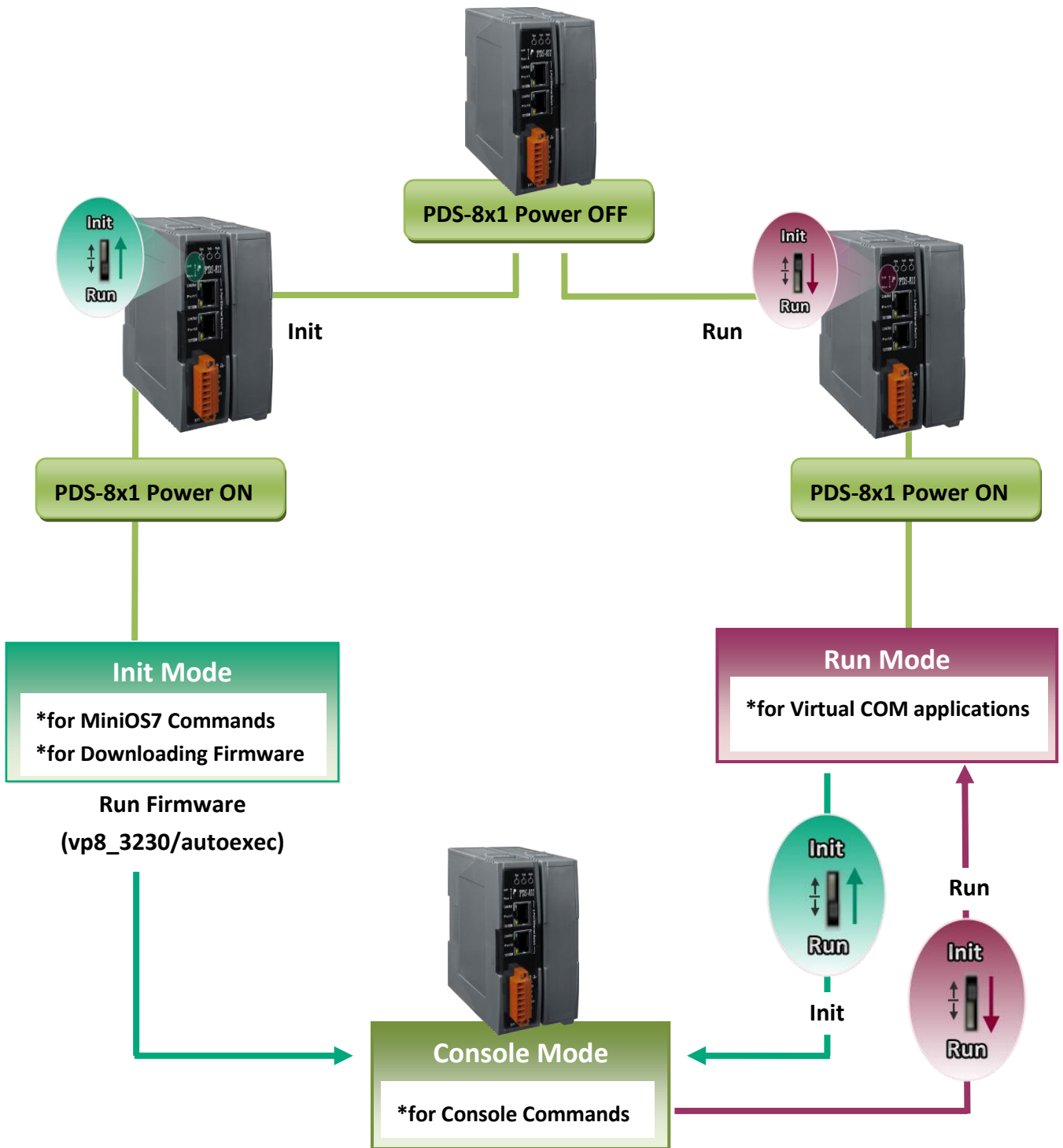

## 6.2 Comparison Sheet (Init, Run and Console Modes)

Mode	Firmware	VCOM Commands	Telnet Commands	Console Commands
Init	Stop	No	No	No
	Init Mode is used to upgrade firmware and accepts MiniOS7 commands (from PDS.COM1) only.			
Run	Running	Yes	Yes	No
	Run Mode is used for Virtual COM applications, and accepts Virtual COM commands (TCP port 10000) and Telnet commands (TCP port 23).			
Console	Running	Yes	Yes	Yes
	Console Mode is used to configure the Virtual COM. PDS.COM1 is the console port that accepts console commands while other ports are still working with Virtual COM applications.			



## 6.3 Command List

Section	Command	Description
<a href="#">6.3.1</a>	<b>IPFILTER</b>	Retrieves/Sets the IP addresses that are allowed to access the PDS-8x1.
<a href="#">6.3.2</a>	<b>IPCONF</b>	Queries the network configuration. (IP/Mask/Gateway/MAC addresses).
<a href="#">6.3.3</a>	<b>SOCKET</b>	Lists all the status of sockets (Listen/Not Used Yet) together with the type of each socket (TCP Server: Port No./UDP/Unused).
<a href="#">6.3.4</a>	<b>COM</b>	Queries or sets the configuration of the COM Ports (Baud Rate/Parity/Stop Bits)
<a href="#">6.3.5</a>	<b>Broadcast</b>	Queries or sets the Broadcast parameter, which determines whether or not the module can receive Broadcast packets.
<a href="#">6.3.6</a>	<b>SystemTimeout</b>	If PDS-8x1 has no network communications during the SystemTimeout period, the PDS-8x1 will reboot it-self automatically.
<a href="#">6.3.7</a>	<b>SocketTimeout</b>	If there is no data send/receive on the connection during the SocketTimeout period, the PDS-8x1 will close the connection automatically.
<a href="#">6.3.8</a>	<b>M</b>	Gets/Sets the echo mode. /M0: Transparent Mode, Multi-Echo, Data-Shared. /M1: Slave Mode, Single-Echo, None-Shared.
<a href="#">6.3.9</a>	<b>EchoCmdNo</b>	Queries or sets the EchoCmdNo parameter that enables or disables adding Command Number before response.
<a href="#">6.3.10</a>	<b>EndChar</b>	Sets a character that determines the end of a response string.
<a href="#">6.3.11</a>	<b>IP</b>	Queries or sets the IP address.
<a href="#">6.3.12</a>	<b>MASK</b>	Queries or sets the subnet Mask value.
<a href="#">6.3.13</a>	<b>GATEWAY</b>	Queries or sets the Gateway address.
<a href="#">6.3.14</a>	<b>MAC</b>	Queries the MAC address.
<a href="#">6.3.15</a>	<b>NAME</b>	Queries the module name.
<a href="#">6.3.16</a>	<b>ALIAS</b>	Sets the alias for a PDS-8x1.
<a href="#">6.3.17</a>	<b>DHCP</b>	Enables/Disables the DHCP client.
<a href="#">6.3.18</a>	<b>UDP</b>	Sets whether to reply to a UDP search command.
<a href="#">6.3.19</a>	<b>VER</b>	Queries the version information
<a href="#">6.3.20</a>	<b>SAVE</b>	Determines whether or not backup copies of the "autoexec.bat" and "vcom.ini" files are saved when using the "load" command.
<a href="#">6.3.21</a>	<b>LOAD</b>	Loads file to the built-in flash disk on PDS-8x1. It should be used to update firmware only.
<a href="#">6.3.22</a>	<b>CONFIG</b>	Restores the factory default settings.
<a href="#">6.3.23</a>	<b>RESET</b>	Reboots the PDS-8x1 module.
<a href="#">6.3.24</a>	<b>QUIT</b>	Exits the running firmware.

### 6.3.1 IPFILTER

This command is used to query or edit IP filter table. The IP filter table restricts the access of packets based on the IP header. If one or more IP addresses are saved into the IP filter table, only clients whose IP is specified in the IP filter table can access the PDS-8x1.

**Effect:** Immediate

Command	Arguments	Description
<b>ipfilter</b>		Queries the IP filter table.
<b>ipfilter</b>	ADD ip1	Adds an IP address to the IP filter table.
<b>ipfilter</b>	ADD ip1 ip2	Adds a range of IP addresses (ip1 ~ ip2) to the IP filter table.
<b>ipfilter</b>	DEL ip1	Deletes an IP address (ip1) from the IP filter table.
<b>ipfilter</b>	DEL ip1 ip2	Deletes a range of IP addresses (ip1 ~ ip2) from the IP filter table.
		The IP address that follows the DEL command should already be listed in the IP filter table.
<b>ipfilter</b>	DEL #n	Deletes item “n” from the IP filter table.
<b>ipfilter</b>	DEL @	Deletes all items from the IP filter table.
<b>ipfilter</b>	SAVE	Saves the IP filter table to the EEPROM. If the IP filter table is empty, the data in EEPROM will be cleared.
<b>ipfilter</b>	LOAD	Loads the IP filter table from the EEPROM.

※The IP filter table is loaded automatically when the PDS-8x1 is booted.

※Use the “ipfilter save” command to save a new IP filter table to the EEPROM.

Refer to Figure 6-3.1 for detail illustrations.

Figure 6-3.1: The following is an example of a **IPFILTER** configuration.

```

7188XW 1.36 [COM1:115200,N,8,1],FC=0,CTS=0, DIR=C:\Documents and Settings\User\桌面\PDS8...
Ucom3231>ipfilter
IP filter #0:ip=10.0.8.20

Ucom3231>ipfilter add 10.0.8.25
IP filter #0:ip=10.0.8.20
IP filter #1:ip=10.0.8.25

Ucom3231>ipfilter add 10.0.8.30 10.0.8.40
IP filter #0:ip=10.0.8.20
IP filter #1:ip=10.0.8.25
IP filter #2:ip range=10.0.8.30 ~ 10.0.8.40

Ucom3231>ipfilter del 10.0.8.30 10.0.8.40
IP filter #0:ip=10.0.8.20
IP filter #1:ip=10.0.8.25

Ucom3231>ipfilter del #0
IP filter #0:ip=10.0.8.25

Ucom3231>ipfilter del @
No IP Filter!

Ucom3231>ipfilter save
[Save 0 IP Filter!]
IP Filter setting is Cleared

Ucom3231>ipfilter load
Load 0 IpFilter setting
No IP Filter!
    
```

## 6.3.2 IPCONF

This command is used to display the network configuration information, such as IP address, Mask Address, Gateway address and MAC address and the status of DHCP, ACK\_Delay, Free Memory and Socket status.

**Effect:** Immediate

Command	Arguments	Description
<b>ipconf</b>		Queries the network configuration.

Figure 6-3.2: The following is an example of a **IPCONF** configuration.

```

Ucom3231>ipconf
IP=10.0.8.246
MASK=255.255.255.0
GATEWAY=10.0.8.254
MAC=00:0D:E0:E0:37:2B
DHCP=0
ACK_Delay=50
Free Memory=440848 bytes
Socket number=32,Free socket number=23
    
```

### 6.3.3 SOCKET

This command lists the status of all sockets (Listen/Not Used Yet) together with the type of each socket (TCP Server: Port No./UDP/Unused)

If stat = 1, the socket is used.

If stat = 0, the socket is not yet used.

**Effect:** Immediate

Command	Arguments	Description
socket		Lists the status of all sockets.

Figure 6-3.3: The following is an example of a **SOCKET** configuration.

```

7188X W 1.36 [COM1:115200,N,8,1],FC=0,CTS=0, DIR=C:\Documents and Settings\User\桌面\PDS8...
Ucom3231>socket
[00=16:LISTEN],stat=1 , [01=16:LISTEN],stat=1
[02=16:LISTEN],stat=1 , [03=16:LISTEN],stat=1
[04=16:LISTEN],stat=1 , [05=16:LISTEN],stat=1
[06=16:LISTEN],stat=1 , [07=16:LISTEN],stat=1
[08=00:NOT_USED_YET],stat=1 , [09=00:NOT_USED_YET],stat=0
[10=00:NOT_USED_YET],stat=0 , [11=00:NOT_USED_YET],stat=0
[12=00:NOT_USED_YET],stat=0 , [13=00:NOT_USED_YET],stat=0
[14=00:NOT_USED_YET],stat=0 , [15=00:NOT_USED_YET],stat=0
[16=00:NOT_USED_YET],stat=0 , [17=00:NOT_USED_YET],stat=0
[18=00:NOT_USED_YET],stat=0 , [19=00:NOT_USED_YET],stat=0
[20=00:NOT_USED_YET],stat=0 , [21=00:NOT_USED_YET],stat=0
[22=00:NOT_USED_YET],stat=0 , [23=00:NOT_USED_YET],stat=0
[24=00:NOT_USED_YET],stat=0 , [25=00:NOT_USED_YET],stat=0
[26=00:NOT_USED_YET],stat=0 , [27=00:NOT_USED_YET],stat=0
[28=00:NOT_USED_YET],stat=0 , [29=00:NOT_USED_YET],stat=0
[30=00:NOT_USED_YET],stat=0 , [31=00:NOT_USED_YET],stat=0

Socket Type:
[00]:TCP Server:10001 , [01]:TCP Server:10010
[02]:TCP Server:10011 , [03]:TCP Server:10012
[04]:TCP Server:10013 , [05]:TCP Server:10000
[06]:TCP Server:23 , [07]:TCP Server:80
[08]:UDP , [09]:UnUsed
[10]:UnUsed , [11]:UnUsed
[12]:UnUsed , [13]:UnUsed
[14]:UnUsed , [15]:UnUsed
[16]:UnUsed , [17]:UnUsed
[18]:UnUsed , [19]:UnUsed
[20]:UnUsed , [21]:UnUsed
[22]:UnUsed , [23]:UnUsed
[24]:UnUsed , [25]:UnUsed
[26]:UnUsed , [27]:UnUsed
[28]:UnUsed , [29]:UnUsed
[30]:UnUsed , [31]:UnUsed
    
```

## 6.3.4 COM

This command queries or sets the configuration of the COM Ports (Baud Rate/Parity/Stop bits).

**Effect:** Immediate

Command	Arguments	Description
<b>com</b>		Queries the configuration of all COM Ports.
<b>com</b>	n	Queries configuration of COM Port “n”.  If n = 0, the configuration of all COM Ports will be listed in the same way as using the command “com” above.
<b>com</b>	N= BaudRate, DataBits, Parity,StopBit(s)	Sets the configuration of COM Port “n”.  If n = 0, the settings will be valid for all Com Ports on the PDS-8x1.

Figure 6-3.4: The following is an example of a **COM** configuration.

```

c:\ 7188X W 1.36 [COM1:115200,N,8,1],FC=0,CTS=0, DIR=C:\Documents and Settings\User\桌面\PDS8...
Ucom3231>com
COM 1=9600,8,N,1. connect=0
COM 10(A)=9600,8,N,1. connect=0
COM 11(B)=9600,8,N,1. connect=0
COM 12(C)=9600,8,N,1. connect=0
COM 13(D)=9600,8,N,1. connect=0
Ucom3231>com 10
COM 10(A)=9600,8,N,1. connect=0
Ucom3231>com 1=9600,8,E,1
COM 1=9600,8,E,1. connect=0
Ucom3231>com 0=9600,8,E,1
COM 1=9600,8,E,1. connect=0
COM 10(A)=9600,8,E,1. connect=0
COM 11(B)=9600,8,E,1. connect=0
COM 12(C)=9600,8,E,1. connect=0
COM 13(D)=9600,8,E,1. connect=0
    
```

## 6.3.5 Broadcast

This command is used to Enable/Disable listening broadcast packets on PDS-8x1.

**Effect:** Immediate

Command	Arguments	Description
<b>Broadcast</b>		Queries the Broadcast settings.
<b>Broadcast</b>	= 1	Sets Broadcast = 1. The system is able to receive broadcast packets.
<b>Broadcast</b>	= 0	Sets Broadcast = 0. The system will ignore broadcast packets.

Figure 6-3.5: The following is an example of a **Broadcast** configuration.

```

C:\ 7188X W 1.36 [COM1:115200,N,8,1],FC=0,CTS=0, DIR=C:\Documents and Settings\User\桌面\PDS8...
Ucom3231>broadcast
BroadCast=1
Ucom3231>broadcast=0
BroadCast=0
Ucom3231>broadcast=1
BroadCast=1
    
```

## 6.3.6 SystemTimeout

This command queries or sets the system timeout value.

If the SystemTimeout is greater than zero, and the PDS-8x1 does not receive any packets from any client for longer than the SystemTimeout period, the PDS-8x1 will reboot itself.

**Effect:** Immediate

Command	Arguments	Description
<b>SystemTimeout</b>		Queries the SystemTimeout settings.
<b>SystemTimeout</b>	= nnnnn	Sets the SystemTimeout. (Unit : ms) Default factory setting is 300000 ms (= 300 seconds = 5 minutes ) Min. value is 30000 ms (= 30 seconds)

Figure 6-3.6: The following is an example of a **SystemTimeout** configuration.

```

c:\ 7188X W 1.36 [COM1:115200,N,8,1],FC=0,CTS=0, DIR=C:\Documents and Settings\User\桌面\PDS8...
Ucom3231>systemtimeout
SystemTimeout=0
Ucom3231>systemtimeout=400000
SystemTimeout=400000
Ucom3231>systemtimeout=0
SystemTimeout=0
    
```



## 6.3.7 SocketTimeout

This command is used to query or set the SocketTimeout parameter.

If the SocketTimeout is greater than zero, and the PDS-8x1 does not receive any data from a client PC for longer than the SocketTimeout period, the PDS-8x1 will close the socket connection between itself and the client PC.

**Effect:** Immediate

Command	Arguments	Description
<b>SocketTimeout</b>		Queries the SocketTimeout settings.
<b>SocketTimeout</b>	= nnnnn	Sets the SocketTimeout. (Unit : ms)
		Default = 0 (disable)
		Min. = 10000

Figure 6-3.7: The following is an example of a **SocketTimeout** configuration.

```

7188X W 1.36 [COM1:115200,N,8,1],FC=0,CTS=0, DIR=C:\Documents and Settings\User\桌面\PDS8...
Ucom3231>sockettimeout
SocketTimeout=0
Ucom3231>sockettimeout=20000
SocketTimeout=20000
Ucom3231>sockettimeout=0
SocketTimeout=0
    
```

## 6.3.8 M

This command is used to query or set the echo mode.

**Effect:** Immediate

Command	Arguments	Description
M		Queries the echo mode settings.
M	= 0	Sets the Multi-echo mode to enable.  When set to multi-echo mode, the PDS-8x1 echoes data from a device to all clients that are connected.
M	= 1	Sets the Single-echo mode to enable.  When set to single-echo mode, the PDS-8x1 echoes data from a device to the client that requested the service.
M	=2	Sets the Half-Save Mode to enable.  If only one client connects to the PDS-8x1 controller, the operation mode same as M0 mode; and if there are two or more clients connecting to the PDS-8x1 controller, the operation mode same as M1 mode.

Figure 6-3.8: The following is an example of a **M** configuration.

```

C:\> 7188 W 1.36 [COM1:115200,N,8,1],FC=0,CTS=0, DIR=C:\Documents and Settings\User\桌面\PDS8...
Ucom3231>m
M=0
Ucom3231>m=1
M=1
Ucom3231>m=2
M=2
Ucom3231>m=0
M=0
    
```

### 6.3.9 EchoCmdNo

This command is used to query or set the EchoCmdNo parameter.

The EchoCmdNo parameter is used to set whether the PDS-8x1 prefixes the Virtual COM command to the corresponding response. (Virtual COM commands are used to configure a PDS-8x1 through TCP port 10000)

**Effect:** Immediate

Command	Arguments	Description
EchoCmdNo		Queries the EchoCmdNo settings.
EchoCmdNo	= 0	If EchoCmdNo = 0, a Virtual COM command number will not be prefixed to the corresponding response.
EchoCmdNo	= 1	If EchoCmdNo = 1, a Virtual COM command number will be prefixed to the corresponding response.

Figure 6-3.9: The following is an example of a **EchoCmdNo** configuration.

```

c:\ 7188X W 1.36 [COM1:115200,N,8,1],FC=0,CTS=0, DIR=C:\Documents and Settings\User\桌面\PDS8...
Ucom3231>echocmdno
EchoCmdNo=0
Ucom3231>echocmdno=1
EchoCmdNo=1
Ucom3231>echocmdno=0
EchoCmdNo=0
    
```

EchoCmdNo = 0

**Send Command**

Send 13

Response 10.0.8.254

EchoCmdNo = 1

**Send Command**

Send 13

Response 1310.0.8.254

### 6.3.10 EndChar

This command is used to query or set the EndChar parameter.

PDS-8x1 sends out the response string from serial port to TCP client immediately when it received a char on the response string that matching the EndChar.

Set EndChar = 00 to disable the EndChar feature.

**Effect:** Immediate

Command	Arguments	Description
Endchar		Queries the endchar setting.
Endchar	= HH	Sets the endchar.

**Figure 6-3.10:** The following is an example of a **EndChar** configuration.

```

7188X W 1.36 [COM1:115200,N,8,1],FC=0,CTS=0, DIR=C:\Documents and Settings\User\桌面\PDS8...
Ucom3231>endchar
EndChar=0D
Ucom3231>endchar=0B
EndChar=0B
    
```

**EndChar = 0D**

```

Send 11ah
(Hex) 31 31 61 68
Received
3C 31 31 61 68 3E 0D <11ah>
    
```

**EndChar = 0B**

```

Send 11ah
(Hex) 31 31 61 68
Received
3C 31 31 61 68 3E 0B <11ah>
    
```

### 6.3.11 IP

This command is used to query or set the IP address.

**Effect:** After the next reboot.

Command	Arguments	Description
IP		Queries the IP address.
IP	= xxx.xxx.xxx.xxx	Sets the IP address.

Figure 6-3.11: The following is an example of a **IP** configuration.

```

7188X W 1.36 [COM1:115200,N,8,1],FC=0,CTS=0, DIR=C:\Documents and Settings\User\桌面\PDS8...
Ucom3231>ip
IP=10.0.8.246
Ucom3231>ip=10.0.8.245
IP=10.0.8.245
    
```

### 6.3.12 MASK

This command is used to query or set the subnet Mask value.

**Effect:** After the next reboot.

Command	Arguments	Description
MASK		Queries the subnet Mask value.
MASK	= xxx.xxx.xxx.xxx	Sets the subnet Mask value.

Figure 6-3.12: The following is an example of a **MASK** configuration.

```

7188X W 1.36 [COM1:115200,N,8,1],FC=0,CTS=0, DIR=C:\Documents and Settings\User\桌面\PDS8...
Ucom3231>mask
MASK=255.255.255.0
Ucom3231>mask=255.255.255.254
MASK=255.255.255.254
    
```

### 6.3.13 GATEWAY

This command is used to query or set the outgoing Gateway address of the subnet.

**Effect:** After the next reboot.

Command	Arguments	Description
<b>Gateway</b>		Queries the subnet Gateway value.
<b>Gateway</b>	= xxx.xxx.xxx.xxx	Sets the subnet Gateway value.

Figure 6-3.13: The following is an example of a **Gateway** configuration.

```

7188X W 1.36 [COM1:115200,N,8,1],FC=0,CTS=0, DIR=C:\Documents and Settings\User\桌面\pds7...
Ucom3230>gateway
GATEWAY=10.0.8.254
Ucom3230>gateway=10.0.8.255
GATEWAY=10.0.8.255
    
```

### 6.3.14 MAC

This command is used to query the MAC address.

**Effect:** Setting the address is not allowed.

Command	Arguments	Description
<b>MAC</b>		Queries the MAC address.( Setting the address is not allowed)

Figure 6-3.14: The following is an example of a **MAC** configuration.

```

C:\ 7188X W 1.36 [COM1:115200,N,8,1],FC=0,CTS=0, DIR=C:\Documents and Settings\User\桌面\PDS8...
Ucom3231>mac
MAC=00:0D:E0:E0:37:2B
    
```

### 6.3.15 NAME

This command is used to query the name of a PDS-8x1 controller.

**Effect:** Setting the address is not allowed.

Command	Arguments	Description
NAME		Queries the name of a PDS-8x1 controller.

Figure 6-3.15: The following is an example of a **NAME** configuration.

```

c:\ 7188XW 1.36 [COM1:115200,N,8,1],FC=0,CTS=0, DIR=C:\Documents and Settings\User\桌面\PDS8...
Ucom3231>name
NAME=PDS-821:1-40
    
```

### 6.3.16 ALIAS

This command is used to query or set the alias of a PDS-8x1. The maximum character length of PDS-8x1 alias name is 16 bytes.

**Effect:** Immediate

Command	Arguments	Description
alias		Queries the alias.
alias	= xxxx	Sets the alias of a PDS-8x1 controller to "xxxx".

Figure 6-3.16: The following is an example of a **alias** configuration.

```

c:\ 7188XW 1.36 [COM1:115200,N,8,1],FC=0,CTS=0, DIR=C:\Documents and Settings\User\桌面\PDS8...
Ucom3231>alias
ALIAS=
Ucom3231>alias=P800
ALIAS=P800
    
```

### 6.3.17 DHCP

This command is used to set the DHCP client to either enabled or disabled.

DHCP function will get a dynamic IP address setting for PDS-8x1 automatically. Thus it's recommended to disable DHCP function and use a static IP address setting. This prevents you to configure virtual COM mappings again and again.

**Effect:** Immediate

Command	Arguments	Description
DHCP	= 0	Disables the DHCP client.
DHCP	= 1	Enables the DHCP client.

Figure 6-3.17: The following is an example of a **DHCP** configuration.

```

7188X W 1.36 [COM1:115200,N,8,1],FC=0,CTS=0, DIR=C:\Documents and Settings\User\桌面\PDS8...
Ucom3231>dhcp
DHCP=0
Ucom3231>dhcp=1
DHCP=1
Ucom3231>dhcp=0
DHCP=0
    
```



## 6.3.18 UDP

This command is used to configure the UDP Search function.

UDP is used to set the action mode for when a PDS-8x1 receives a UDP search command.

**Effect:** Immediate

Command	Arguments	Description
UDP	= 0	Rejects UDP search commands.  The PDS-8x1 will not reply to the UDP search command, and can not be searched again.
UDP	= 1	Replies to UDP search commands.  The PDS-8x1 controller will reply to the UDP search command, and can be searched.
UDP	= 2	Replies to UDP search commands till a client is connected.

Figure 6-3.18: The following is an example of a **UDP** configuration.

```

7188X W 1.36 [COM1:115200,N,8,1],FC=0,CTS=0, DIR=C:\Documents and Settings\User\桌面\PDS8...
Ucom3231>udp
UDP=2
Ucom3231>udp=0
UDP=0
Ucom3231>udp=1
UDP=1
Ucom3231>udp=2
UDP=2
    
```

## 6.3.19 VER

This command is used to query the version information for a PDS-8x1.

**Effect:** Setting the version information is not allowed.

Command	Arguments	Description
VER		Queries the version information.

Figure 6-3.19: The following is an example of a **VER** configuration.

```

7188XW 1.36 [COM1:115200,N,8,1],FC=0,CTS=0, DIR=C:\Documents and Settings\User\桌面\PDS8...
Ucom3231>ver
Firmware:v3.2.30[Dec 18 2008]
OS Version:2.6.2[Dec 07 2007]
P824AL.LIB Ver. 2.3[Nov 14 2008],tcp_dm32.LIB Ver. 1.20[Dec 08 2008]
    
```

## 6.3.20 SAVE

This command is used to set the PDS-8x1 to backup or no-backup “**autoexec.bat**” and “**vcom.ini**” files when using “load” command.

**Effect:** Immediate

Command	Arguments	Description
save	= 1	When the “load” command is used, backup copies of the “autoexec.bat” and “vcom.ini” files will be saved.
save	= 0 (Default)	When the “load” command is used, backup copies of the “autoexec.bat” and “vcom.ini” files will NOT be saved.

Refer to Figures 6-3.20 and 6-3.21 for detail illustrations.

### 6.3.21 LOAD

This command is used to load file to the built-in flash disk on PDS-8x1. It should be used to update firmware only.

**Effect:** Immediate

Command	Arguments	Description
load		The command is coordinated with the MiniOS7 "load" command and can be used to renew the "vcom3230.exe," "vcom.ini" or "autoexec.bat" file(s).

※ "Load" is not a Telnet command.

Figure 6-3.20: The following is an example of a **Save = 0** configuration.

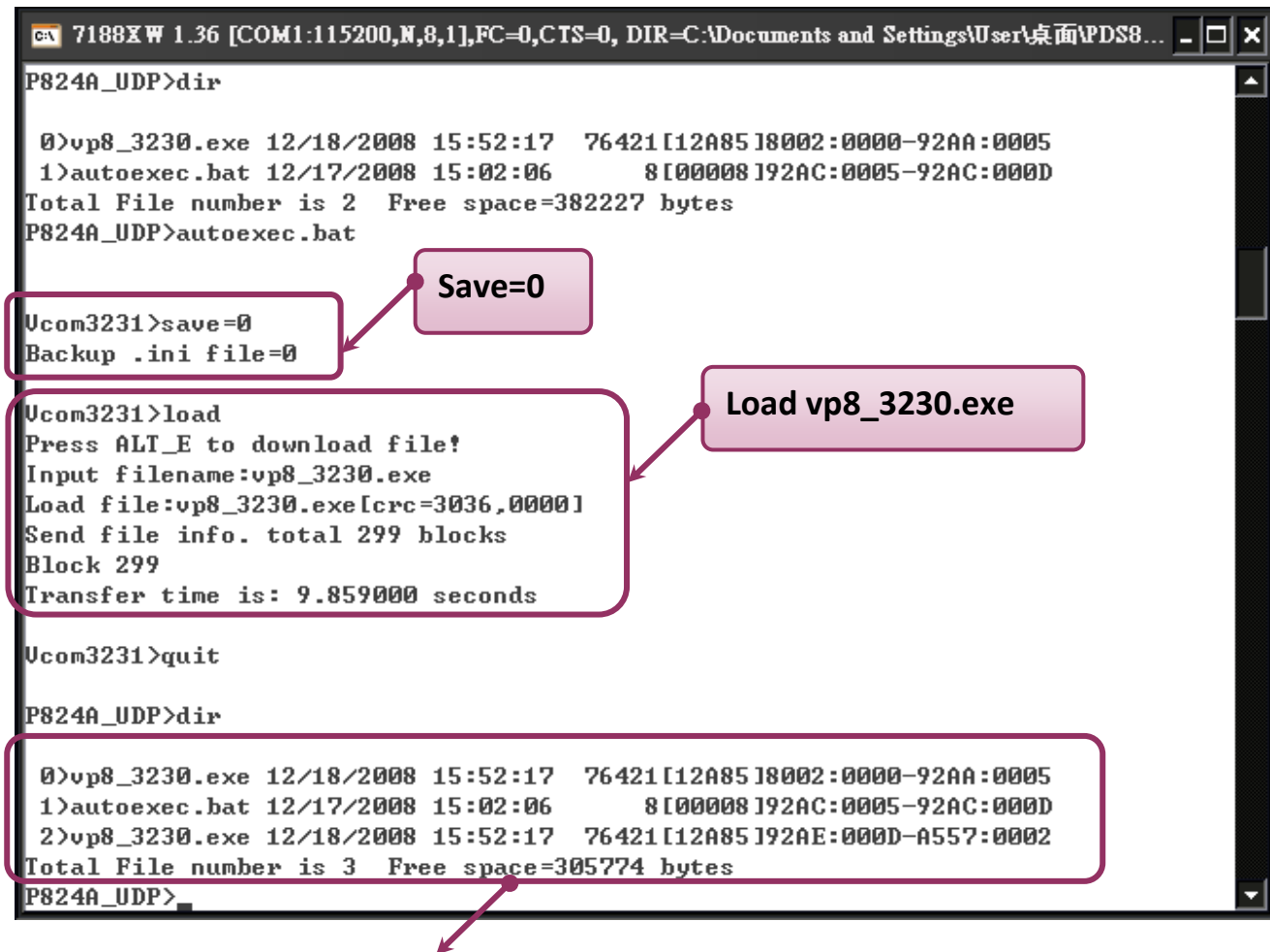

※ When save = 0, the system doesn't back up the "autoexec.bat" and "vcom.ini" files to memory, and doesn't clear the flash disk. It only loads the file that is selected specified.

Figure 6-3.21: The following is an example of a **Save = 1** configuration.

```
7188XW 1.36 [COM1:115200,N,8,1],FC=0,CTS=0, DIR=C:\Documents and Settings\User\桌面\PDS8...
P824A_UDP>dir
 0>vp8_3230.exe 12/18/2008 15:52:17 76421 [12A85]8002:0000-92AA:0005
 1>autoexec.bat 12/17/2008 15:02:06 8 [000008]92AC:0005-92AC:000D
Total File number is 2 Free space=382227 bytes
P824A_UDP>autoexec.bat

Ucom3231>save=1
Backup .ini file=1

Ucom3231>load
save file:autoexec.bat
Press ALT_E to download file!
Input filename:vp8_3230.exe
Load file:vp8_3230.exe [crc=3036,0000]
Send file info. total 299 blocks
Block 299
Transfer time is: 9.875000 seconds

Ucom3231>quit
Command not supported !

P824A_UDP>dir
 0>autoexec.bat 12/17/2008 15:02:06 8 [000008]8002:0000-8002:0008
 1>vp8_3230.exe 12/18/2008 15:52:17 76421 [12A85]8004:0008-92AC:000D
Total File number is 2 Free space=382227 bytes
P824A_UDP>
```

※ When save = 1, system will back up the "autoexec.bat" and "vcom.ini" files to memory first, clear all files in the flash disk, and then load the "autoexec.bat" and "vcom.ini" files from memory and run the "load" command to load the specified file(s).

## 6.3.22 CONFIG

This command is used to clear the settings in the EEPROM.

**Effect:** Immediate

Command	Arguments	Description
config	= RESET	<p>Clears the settings in the EEPROM.</p> <p>After reboot, the firmware will use the new (default) settings on EEPROM.</p> <p><b>Note: "RESET" MUST be in capital letters.</b></p>

※When “Config=RESET” is used, the Password, Alias and IPFILTER settings will also be cleared, but the IP/MASK/GATEWAY addresses will not.

※The SystemTimeout setting is also cleared to 0 by the "config=RESET" command, you have to configure the SystemTimeout value again. The default factory setting of SystemTimeout value should be 300000 ms (= 300 seconds).

Figure 6-3.22: The following is an example of a **CONFIG** configuration.

```

7188X W 1.36 [COM1:115200,N,8,1],FC=0,CTS=0, DIR=C:\Documents and Settings\User\桌面\PDS8...
Ucom3231>config=RESET
Ucom3231>
    
```

### 6.3.23 RESET

This command is used to reboot the PDS-8x1 controller.

**Effect:** Immediate

Command	Arguments	Description
reset		Reboot the PDS-8x1 controller.

Figure 6-3.23: The following is an example of a **RESET** configuration.

```

C:\> 7188XW 1.36 [COM1:115200,N,8,1],FC=0,CTS=0, DIR=C:\Documents and Settings\User\桌面\PDS8...
Ucom3231>reset

ICP_DAS MiniOS7 for I-P824A Ver. 2.06 build 002,Dec 07 2007 17:04:24
OS id=23
SRAM:768K, FLASH MEMORY:512K
[CPU=RDC 1120]
CPU internal WDT is ENABLED(WDT timeout=0.8 sec)

P824A_UDP>_
    
```

### 6.3.24 QUIT

This command is used to stop and quit the firmware of PDS-8x1 controller.

**Effect:** Immediate

Command	Arguments	Description
quit		Quits the firmware.

Figure 6-3.24: The following is an example of a **Quit** configuration.

```

C:\> 7188XW 1.36 [COM1:115200,N,8,1],FC=0,CTS=0, DIR=C:\Documents and Settings\User\桌面\PDS8...
Ucom3231>quit

P824A_UDP>_
    
```

# Appendix A: Linking to a Development PC

**Step 1:** Connect the download-cable (CA0910), between the PDS-8x1 controller and COM 1 of the development PC.

- 1-1: Connect the connector of CA-0910 download cable to your host computer.
- 1-2: Wire the CA-0910 to PDS-8x1 controller, as follows:

Connect the CA-0910.TX with PDS-8x1.TxD

Connect the CA-0910.RX with PDS-8x1.RxD

Connect the CA-0910.GND with PDS-8x1.GND

**Step 2:** Set the Init/Run Switch in “Init Mode” position.

**Step 3:** Supply +24 V<sub>DC</sub> (+10 ~ +30 V<sub>DC</sub>) power to the PDS-8x1 controller.

Refer to below illustration for how to perform the above procedure.

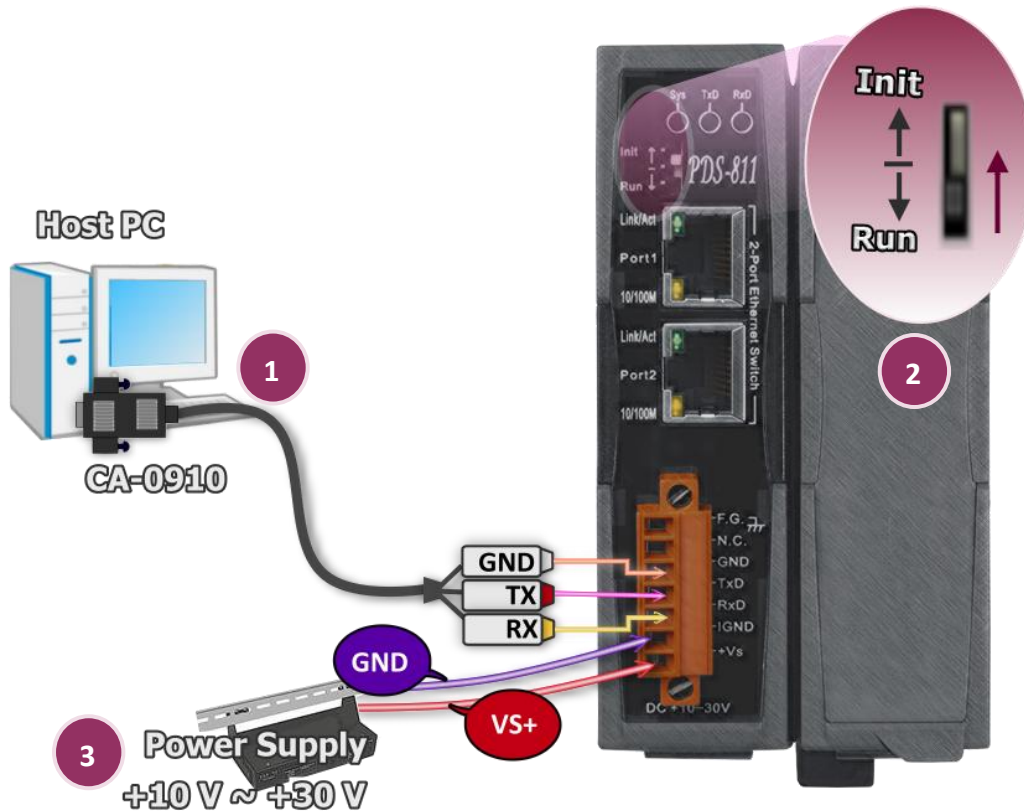

**Step 4:** Verify that the System LED indicator is flashing on the PDS-8x1 controller.



**Step 5:** Unzip the “7188XW\_yyyymmdd.zip” file on the PC.

The “7188XW\_yyyymmdd.zip” can be obtained from either the companion CD-ROM, the ICP DAS FTP site, or the ICP DAS web site. The location of the install files on the CD and the download addresses are shown below:



CD:\\ NAPDOS\\MiniOS7\\Utility\\



<http://ftp.icpdas.com/pub/cd/8000cd/napdos/minios7/utility/>

**Step 6:** Execute 7188XW.EXE/C#, and change the Baud Rate to 115200 bps, N81. “/C#” is the COM Port of the development PC.

**Step 7:** Press [↵ Enter] twice on the development PC.

```

7188XW 1.36 [COM1:115200,N,8,1],FC=0,CTS=0, DIR=C:\
7188x for WIN32 version 1.36 (2008/02/26)[By ICP DAS. Tim Tsai.]
[Begin Key Thread...]Current set: Use COM1 115200,N,8,1
AutoRun:
Autodownload files: None
Current work directory="C:\\"
original baudrate = 115200!
now baudrate = 115200!

P824A_UDP>_
    
```



**Step 8:** Read the configuration of the PDS-8x1 (The following is a default value).

```
P824A_UDP>ip
IP=192.168.255.1
P824A_UDP>mask
MASK=255.255.0.0
P824A_UDP>gateway
Gateway=192.168.0.1
P824A_UDP>mac
Ethernet Address = 00:0d:e0:e0:37:2b
P824A_UDP>setcom 1
Current set is: 9600,8,0,1
```

- Read configuration command
- Ip
  - Mask
  - Gateway
  - Mac
  - setcom port

**Step 9:** The configuration of the PDS-8x1 as follows can be changed.

Please setting for with your PC same network region **IP/Mask/Gateway addresses**.

This example: **10.0.8.246/255.255.255.0/10.0.8.255**

```
P824A_UDP>ip 10.0.8.246
Set IP=10.0.8.246
[ReadBack]IP=10.0.8.246
P824A_UDP>mask 255.255.255.0
Set MASK=255.255.255.0
[ReadBack]MASK=255.255.255.0
P824A_UDP>gateway 10.0.8.255
Set GATEWAY=10.0.8.255
[ReadBack]Gateway=10.0.8.255
P824A_UDP>setcom 1 115200,n,8,1
Current set is: 9600,8,0,1
Set to: 115200,8,0,1 [checksum:CC]
```

- Settings configuration command
- ip [new ip]
  - mask [new mask]
  - gateway [new gateway]
  - mac [new mac]
  - setcom port (refer to Table A-1)
  - [baud][data\_bit][parity][stop\_bit]

Table A-1: “setcom” parameters are as follows.

<b>Port</b>	1
<b>Baud Rate</b>	2 ~ 921600
<b>Data Bit</b>	7, 8: for COM 1
<b>Parity</b>	N, n : None parity E, e : Even parity O, o : Odd parity
<b>Stop Bit</b>	1: for COM 1

**Step 10:** Set the Init/Run Switch in “Run Mode” position, and then **power-on reboot** the PDS-8x1 controller.

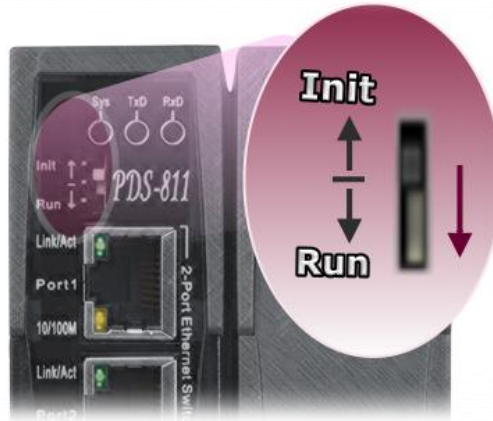

**Step 11:** Execute ping you setting IP (Example: ping 10.0.8.246 -t) using a run command.

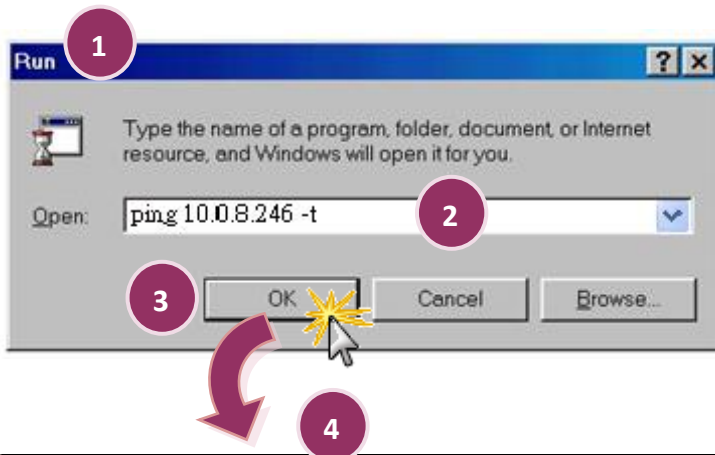

```
Pinging 10.0.8.246 with 32 bytes of data:  
Reply from 10.0.8.246: bytes=32 time=1ms TTL=64  
Reply from 10.0.8.246: bytes=32 time<1ms TTL=64  
Reply from 10.0.8.246: bytes=32 time<1ms TTL=64  
Reply from 10.0.8.246: bytes=32 time<1ms TTL=64  
Reply from 10.0.8.246: bytes=32 time<1ms TTL=64  
Reply from 10.0.8.246: bytes=32 time<1ms TTL=64  
Reply from 10.0.8.246: bytes=32 time<1ms TTL=64  
Reply from 10.0.8.246: bytes=32 time<1ms TTL=64  
Reply from 10.0.8.246: bytes=32 time<1ms TTL=64  
Reply from 10.0.8.246: bytes=32 time<1ms TTL=64
```

Follow the procedure described below:

1. Click the “Start” button and then click “Run” to open the “Run Command” dialog box.
2. In the “Run Command” dialog box, type “pin 10.0.8.246 -t” in the “Open:” field.
3. Click the “OK” button to open a Command Prompt window.
4. The ping results should be smooth and continuous



Note:

1. **192.168.255.1** is the default IP of the PDS-8x1 controller. The IP address can be changed using the instructions in step 8.
2. If the PDS-8x1 cannot be successfully pinged from the PC, refer to step 8 to change the configuration of the PDS-8x1 controller. (The mask and gateway addresses of PDS-8x1 controller and the PC should make the network definition.)
3. The MAC address of the PDS-8x1 controller should be unique on the same network. Refer to step 8 for details of how to change the MAC address of the PDS-8x1 controller.
4. Each PDS-8x1 MAC address is unique in the default shipping.

In general, if the host PC can ping the PDS-8x1 controller smoothly and continuously, all other software and drivers for the PDS-8x1 controller will operate correctly. Therefore, users should ensure that the development PC is able to ping the PDS-8x1 controller smoothly before any further testing is carried out.

# Appendix B: Glossary

## 1. ARP (Address Resolution Protocol)

The Address Resolution Protocol (ARP) is a telecommunication protocol that is used to convert an IP address to a physical address, such as an Ethernet address.

Consider two machines A and B that share the same physical network. Each has an assigned IP address  $IP_A$  and  $IP_B$ , and a MAC address,  $MAC_A$  and  $MAC_B$ . The goal is to devise a low-level software application that hides the MAC addresses and allows higher-level programs to work only with the IP addresses. Ultimately, however, communication must be carried out by the physical networks using whatever MAC address scheme the hardware supplies.

Suppose machine A wants to send a packet to machine B across a physical network to which they are both attached, but A only has the Internet address for B,  $IP_B$ . The question arises: how does A map that address to the MAC address for B,  $MAC_B$ ?

ARP provides a method of dynamically mapping 32-bit IP address to the corresponding 48-bit MAC address. The term dynamic is used since the mapping is performed automatically and is normally not a concern for either the application user or the system administrator.

## 2. Clients and Servers

The client-server paradigm uses the direction of initiation to categorize whether a program is a client or server. In general, an application that initiates peer-to-peer communication is called a client. End users usually invoke client programs when they use network services.

By comparison, a server is any program that waits for incoming requests from a client program. The server receives a request from a client, performs the necessary actions and returns the result to the client.

### 3. Ethernet

The term Ethernet generally refers to a standard published in 1982 by Digital Equipment Corp., Intel Corp. and Xerox Corp. Ethernet is the most popular physical layer Local Area Network (LAN) technology in use today.

### 4. Firmware

Firmware is an embedded software program or set of instructions programmed on a device that provides the necessary instructions for how the device communicated with other computer hardware, and is located or stored in a semi-permanent storage area, e.g., ROM, EEPROM, or Flash memory. Firmware can often be updated by downloading a file from the manufacturer's web site or FTP.

### 5. Gateway

Computers that interconnect two networks and pass packets from one to the other are called Internet Gateways or Internet Routers. Gateways route packets that are based on the destination network, rather than the destination host.

### 6. ICMP (Internet Control Message Protocol)

ICMP provides a method of communicating between the Internet Protocol software on one machine and the corresponding software on another. It allows a gateway to send error or control messages to other gateways, or allows a host to diagnose problems with the network communication.

### 7. Internet

Physically, the Internet is a collection of packet switching networks interconnected by gateways that together with the TCP/IP protocol, allows them to perform logically as a single, large and virtual network. The Internet recognizes hosts using 32-bit IP address.

## 8. IP (Internet Protocol) Address

Each interface on the Internet must have a unique IP address (also called an Internet address). These addresses are 32-bit numbers, and are normally written as four decimal numbers, one for each byte of the address for example “192.168.41.1”. This is called dotted-decimal notation.

## 9. MAC (Media Access Control) Address

To allow a computer to determine which packets are meant for it, each device attached to an Ethernet network is assigned a 48-bit integer known as its MAC address (also called the Ethernet address, the hardware address or the physical address). A MAC address is normally written as eight hexadecimal numbers, for example “00:71:88:af:12:3e:0f:01”. Ethernet hardware manufacturers purchase blocks of MAC addresses and assign them in sequence as they manufacture Ethernet interface hardware. Thus, no two hardware interfaces can have the same MAC address.

## 10. Packet

A packet is the unit of data sent across a physical network. It consists of a series of bits containing data and control information, including the source and the destination node (host) address, and is formatted for transmission from one node to another.

## 11. Ping

Ping is a network administration utility used to test the whether a host on an Internet network is active, and to measure the round-trip time for messages sent from the originating host to a destination computer. Ping operates by sending an ICMP echo request message to a host, expecting an ICMP echo reply to be returned. Normally, if a host cannot be pinged, Telnet or FTP cannot be used to connect to the host. Conversely, if Telnet or FTP cannot be used to connect to a host, Ping is often the starting point to determine the nature of the problem.

## 12. RARP (Reverse Address Resolution Protocol)

RARP provides a method of dynamically mapping 48-bit MAC address to the corresponding 32-bit IP address. RARP has now been replaced by the Bootstrap Protocol (BOOTP) and the modern Dynamic Host Configuration Protocol (DHCP).

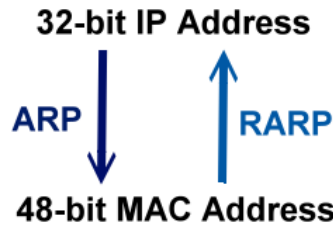

## 13. Socket

Each TCP segment contains a source and destination port number that can be used to identify the sending and receiving application. These two values, along with the source and destination IP addresses in the IP header, uniquely identify each connection. The combination of an IP address and a port number is called a socket.

## 14. Subnet Mask

A Subnet mask, often simply called the “Mask”, is a 32-bit number that masks and IP address, and divides the IP address into the network address and the host address. Given its own IP address and its subnet mask, a host can determine whether a TCP/IP packet is destined for a host that is (1) on its own subnet, or (2) on a different network. If (1), the packet will be delivered directly; otherwise it, will be delivered via a gateway or a router.

## 15. TCP (Transmission Control Protocol)

TCP is a set of rules used in combination with the Internet Protocol to send data in the form of message units between computers over the Internet. TCP provides a reliable flow of data between two hosts and is associated with tasks such as dividing the data passed to it from an application into appropriately sized chunks for the network layer below, acknowledging received packets, setting timeouts to make certain that the other end acknowledges packets that are sent, and so on.

## 16. TCP/IP

The Transmission Control Protocol (TCP) and the Internet Protocol (IP) are standard network protocols that are almost always implemented and used together in a formation is known as TCP/IP. TCP/IP can be used to communicate across any set of interconnected networks.

## 17. UDP (User Datagram Protocol)

UDP is an internet protocol that provides a much simpler service to the application layer as it only sends packets of data from one host to an other, but there is no guarantee that the packets will reach the destination host. UDP is suitable for purposes where error checking and correction is either not necessary or is performed in the application.