

# I-2533T-FD User Manual

Version 1.0.0, April. 2021



Service and usage information for  
I-2533T-FD

## Warranty

---

All products manufactured by ICP DAS are under warranty regarding defective materials for a period of one year, beginning from the date of delivery to the original purchaser.

## Warning

---

ICP DAS assumes no liability for any damage resulting from the use of this product. ICP DAS reserves the right to change this manual at any time without notice. The information furnished by ICP DAS is believed to be accurate and reliable. However, no responsibility is assumed by ICP DAS for its use, not for any infringements of patents or other rights of third parties resulting from its use.

## Copyright

---

Copyright © 2021 by ICP DAS Co., Ltd. All rights are reserved.

## Trademark

---

The names used for identification only may be registered trademarks of their respective companies.

## Contact us

---

If you have any problem, please feel free to contact us.  
You can count on us for quick response.

Email: [service@icpdas.com](mailto:service@icpdas.com)

# Table of Contents

<b>1.</b>	<b><i>Introduction</i></b> .....	<b>5</b>
<b>1.1.</b>	<b>Specifications</b> .....	<b>7</b>
<b>1.2.</b>	<b>Features</b> .....	<b>9</b>
<b>2.</b>	<b><i>Technical data</i></b> .....	<b>10</b>
<b>2.1.</b>	<b>Block Diagram</b> .....	<b>10</b>
<b>2.2.</b>	<b>Appearance</b> .....	<b>11</b>
<b>2.3.</b>	<b>Pin Assignment</b> .....	<b>12</b>
<b>2.4.</b>	<b>10-pin Dip Switch</b> .....	<b>14</b>
<b>2.5.</b>	<b>LED Indicator</b> .....	<b>16</b>
<b>2.6.</b>	<b>Terminal Resistor Setup</b> .....	<b>17</b>
<b>2.7.</b>	<b>Module Group ID</b> .....	<b>19</b>
<b>2.8.</b>	<b>Wire Connection</b> .....	<b>21</b>
<b>3.</b>	<b><i>Network Deployment</i></b> .....	<b>22</b>
<b>3.1.</b>	<b>Driving Capability</b> .....	<b>22</b>
<b>3.2.</b>	<b>Fiber Selection &amp; Fiber Length</b> .....	<b>23</b>
<b>4.</b>	<b><i>Software Utility</i></b> .....	<b>24</b>
<b>4.1.</b>	<b>Install the I-2533CS-FD Utility</b> .....	<b>24</b>
<b>4.2.</b>	<b>Setting up the I-2533T-FD</b> .....	<b>27</b>
<b>4.3.</b>	<b>Start to use I-2533CS-FD Utility tool</b> .....	<b>28</b>
<b>4.3.1.</b>	<b>Connect to the module</b> .....	<b>29</b>
<b>4.3.2.</b>	<b>Get Current Module Settings</b> .....	<b>30</b>
<b>4.3.3.</b>	<b>Configure User-Defined CAN Baudrate</b> .....	<b>31</b>
<b>4.3.4.</b>	<b>Configure Other Parameters</b> .....	<b>32</b>
<b>4.3.5.</b>	<b>Configure CAN ID Filter</b> .....	<b>34</b>
<b>5.</b>	<b><i>Firmware Upgrade</i></b> .....	<b>36</b>
<b>6.</b>	<b><i>Appendix</i></b> .....	<b>40</b>
<b>6.1.</b>	<b>Revision History</b> .....	<b>40</b>
<b>6.2.</b>	<b>Dimension</b> .....	<b>41</b>
<b>6.3.</b>	<b>CAN Status Register</b> .....	<b>42</b>

<b>6.4.</b>	<b>CAN Error Counter Register .....</b>	<b>43</b>
<b>6.5.</b>	<b>Valid CAN FD Data Phase Bit Rat .....</b>	<b>44</b>

# 1. Introduction

The I-2533T-FD is a local CAN/CAN FD (CAN with Flexible Data-Rate) bridge used to establish a connection between two CAN bus system via multi-mode fiber optic transmission medium. In order to solve the problem between CAN/CAN FD and fiber transmission medium, the I-2533T-FD is specially designed for converting the electrical CAN/CAN FD bus signal to fiber optic cables. Besides, I-2533T-FD has three more important features.

First, the transmission distance limitation of the CAN bus system will not be affected due to the different CAN/CAN FD baud rate. It means that the total CAN/CAN FD bus working distance can be extended. Second, the bus error on one CAN/CAN FD network will not affect the operation of another CAN/CAN FD network. Finally, the two CAN/CAN FD networks can communicate with each other by using different CAN/CAN FD baud rates for highly flexibility.

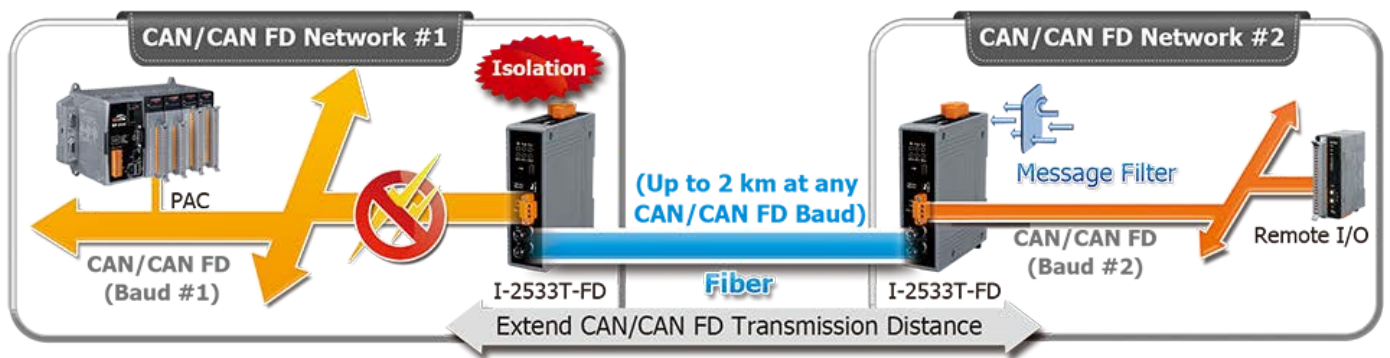

The I-2533T-FD is designed for multi-mode fiber, and allow to extend CAN/CAN FD bus to maximum 2 km. Besides, I-2533T-FD provides the group function, which is the basic message router. Users can decide the CAN/CAN FD message flows between several CAN/CAN FD bus systems. I-2533T-FD also provides the utility tool for user-defined baud rate and filter configuration. By using this tool, it is allowed to have user-defined baud rate and CAN/CAN FD message filter. When users use the I-2533T-FD on two CAN/CAN FD networks with different CAN baud rates, it may be useful to reduce the bus loading of the network which has low baud rate.

**Connect multiple CAN/CAN FD networks  
working at different baud rate**

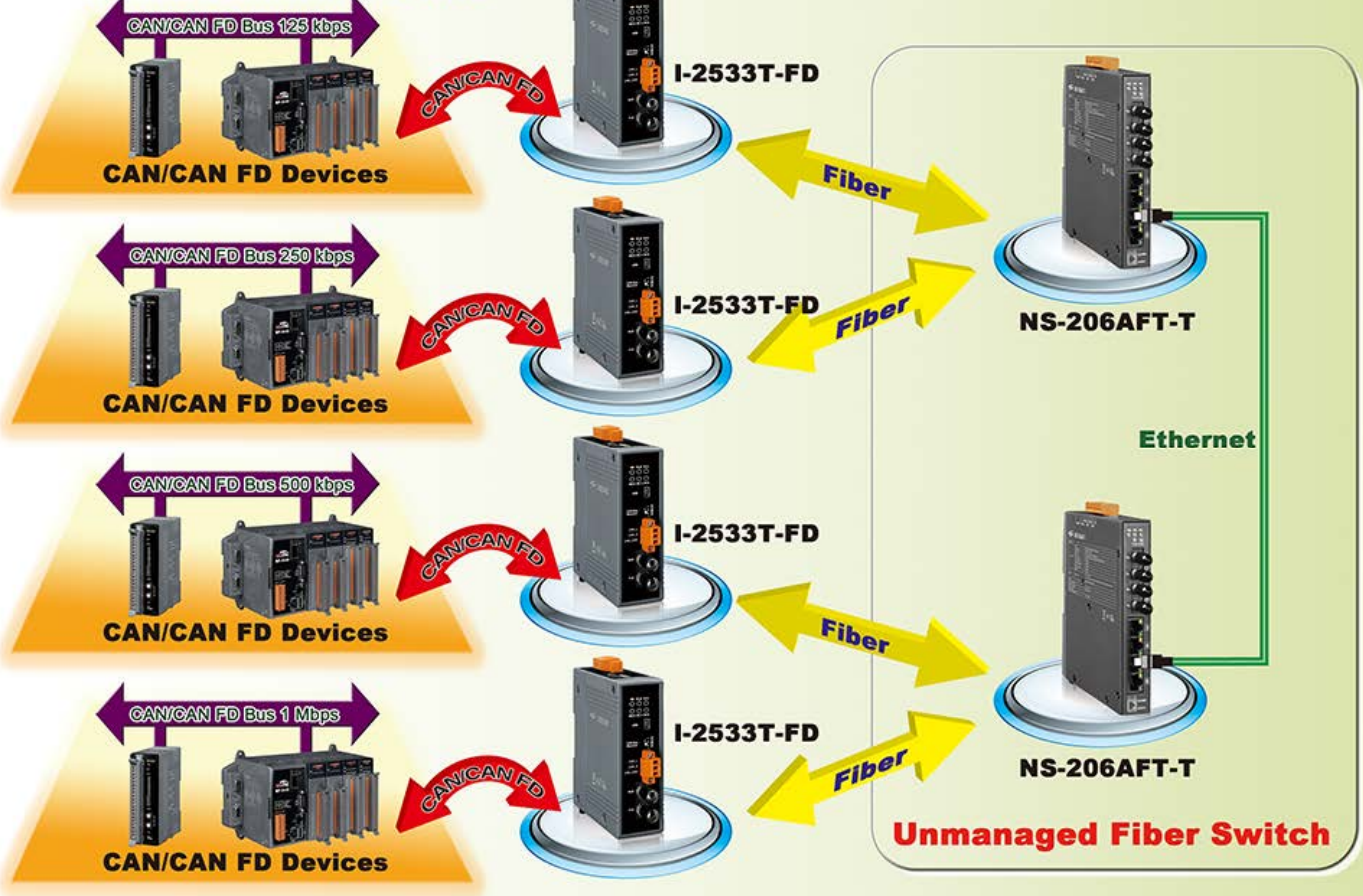

# 1.1. Specifications

<b>Model Name</b>	<b>I-2533T-FD</b>
<b>CAN Interface</b>	
Transceiver	TI TCAN1042HG
Channel Number	1
Connector	3-pin terminal-block connector
Transmission Speed	CAN bit rates: 10 ~ 1000 kbps, CAN FD bit rates for data field: 100 ~ 10000 kbps
Terminal Resistor	DIP switch for the 120 $\Omega$ terminal resistor
Isolation	3000 VDC for DC-to-DC, 2500 Vrms for photocoupler
Specification	ISO 11898-2, CAN 2.0 A/B and FD
CAN Filter Configuration	Selectable via Utility tool
Receive Buffer	128 data frames
<b>Fiber Interface</b>	
Type	ST type ; multi-mode ; 100 Base-FX
Wave Length (nm)	1310
Fiber Cable ( $\mu$ m)	50/125, 62.5/125 or 100/140 (62.5/125 $\mu$ m recommended)
Transmission Distance (km)	2 (theoretical value)
Min. TX Output (dBm)	-20
Max. TX Output (dBm)	-14
Max. RX Sensitivity (dBm)	-32
Max. RX Overload (dBm)	-8
Budget (dBm)	12
<b>USB Interface</b>	
Connector	1 x USB (Mini-B)
Compatibility	USB 2.0 High Speed (480Mbps)
Software Driver	Built-in Windows 7/8.1/10
<b>LED</b>	

Round LED	PWR, FB_Ack, FB_Err, CAN_Err, CAN_Tx and CAN_Rx LEDs
<b>Power</b>	
Power supply	Unregulated +10 ~ +30 V <sub>DC</sub>
Protection	Power reverse polarity protection, Over-voltage brown-out protection
Power Consumption	0.125A @ 24V <sub>DC</sub>
<b>Mechanism</b>	
Installation	DIN-Rail
Dimensions	33.0 mm x 127 mm x 101 mm (W x L x H)
<b>Environment</b>	
Operating Temp.	-25 ~ 75 °C
Storage Temp.	-30 ~ 80 °C
Humidity	10 ~ 90% RH, non-condensing



## 1.2. Features

- Compatible with the ISO 11898-2 standard
- Compatible with CAN specification 2.0 A/B and FD
- CAN FD support for ISO and Non-ISO (Bosch) standards switchable
- CAN FD bit rates for data field from 100 kbps to 10000 kbps
- CAN bit rates from 10 kbps to 1000 kbps
- Fiber broken line detection
- Support CAN Bus message filter configuration
- Support firmware update via USB
- Basic CAN message routing function via Group ID settings.
- Built-in switchable 120 ohm terminal resistor for CAN Bus
- Dip switch for CAN/CAN FD baud rate configuration

## 2. Technical data

### 2.1. Block Diagram

The following figure is the block diagram illustrating the functions of the I-2533T-FD.

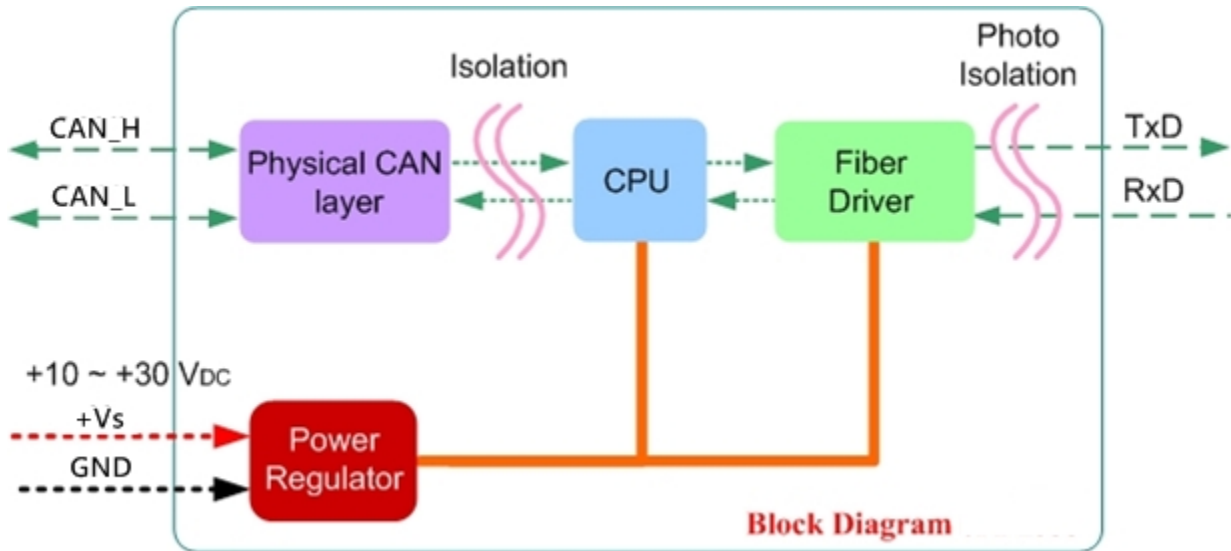

Figure 2-1-1 Block Diagram of I-2533T-FD

## 2.2. Appearance

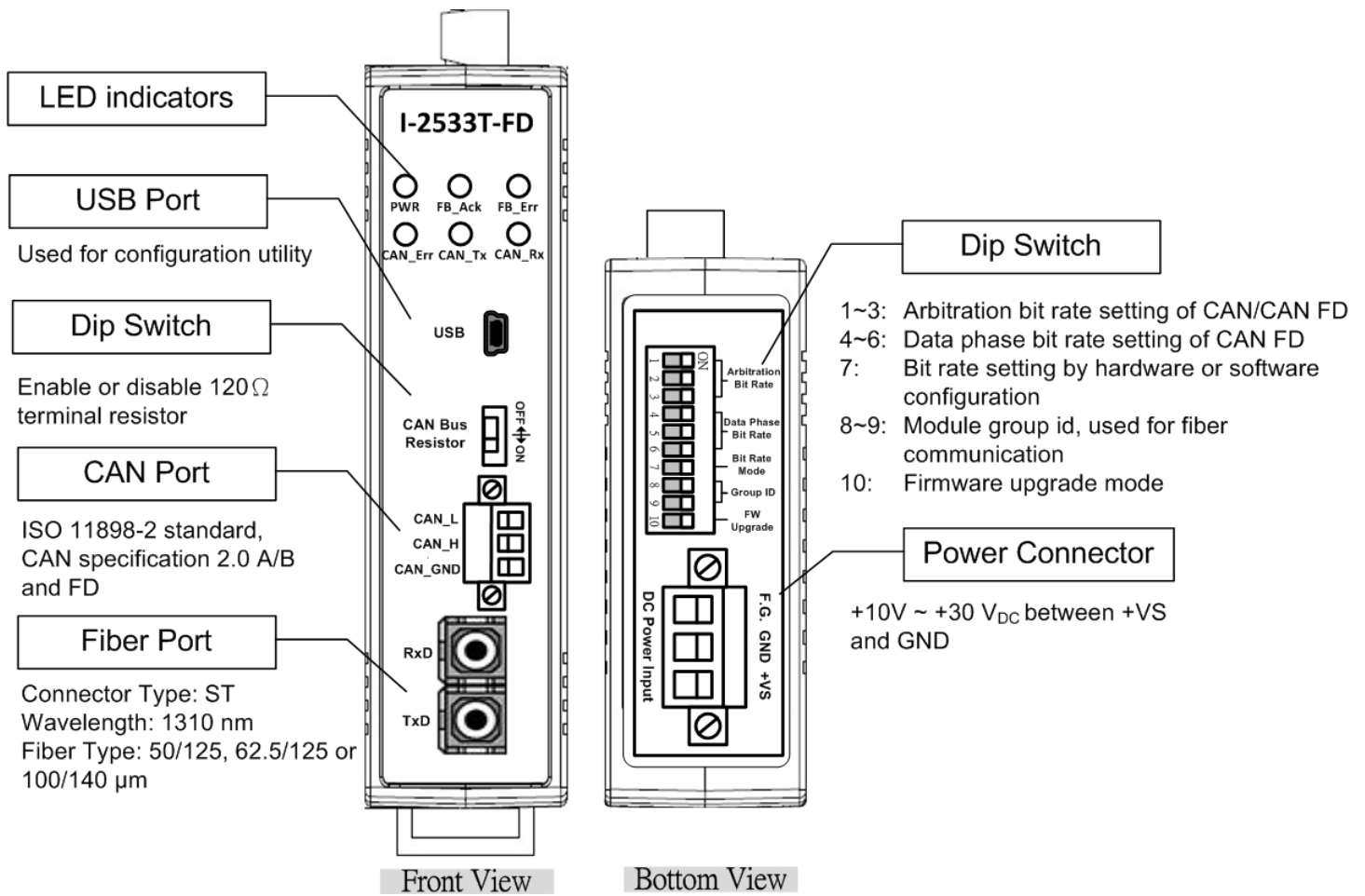

Figure 2-2-1 Appearance of I-2533T-FD

## 2.3. Pin Assignment

The pin assignments of USB, CAN port, fiber port and power connector of I-2533T-FD is shown in the following tables.

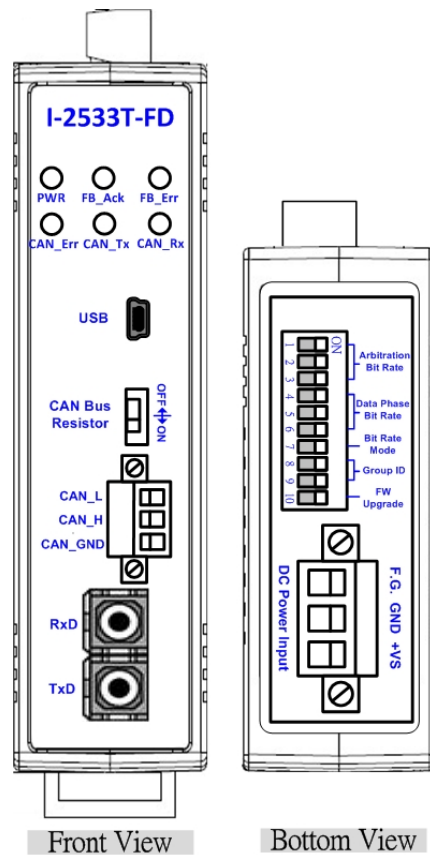

Table 2-3-1 Pin Assignment

Port	Name	Description
USB	USB	Used for configuration utility
CAN	CAN_L	CAN_Low, signal line of CAN port.
	CAN_H	CAN_High, signal line of CAN port.
	CAN_GND	CAN_Ground, ground voltage level of CAN port.
Fiber	TxD	Transmit optic data.
	RxD	Receive optic data.
Power	+Vs	Voltage Source Input. +10V <sub>DC</sub> ~ +30V <sub>DC</sub> .
	GND	Power Ground.
	F.G.	Frame Ground.

Sometimes, the CAN\_GND voltage level of different CAN devices on a CAN bus system are not equal. In this case, it could cause some problems and derogate the system stability. There is one way to relieve this situation; users can connect the CAN\_GND of different CAN devices with each other to balance the voltage level of CAN\_GND.

Electronic circuits are always influenced by different levels of Electro-Static Discharge (ESD), which become worse in a continental climate area. F.G. provides a path for conducting the ESD to the earth ground. Therefore, connecting the F.G. correctly can enhance the capability of the ESD protection and improve the module's reliability.

Wiring of CAN\_GND and F.G. is not necessary; users can modify the configuration of wiring according to real applications.

## 2.4. 10-pin Dip Switch

When users would like to set the CAN/CAN FD baud rate, module's group id or update the firmware of the I-2533T-FD, Users can use the 10-pin dip switch on the upper of the power connector to achieve these purposes. Users can find it on the top of the power connector.

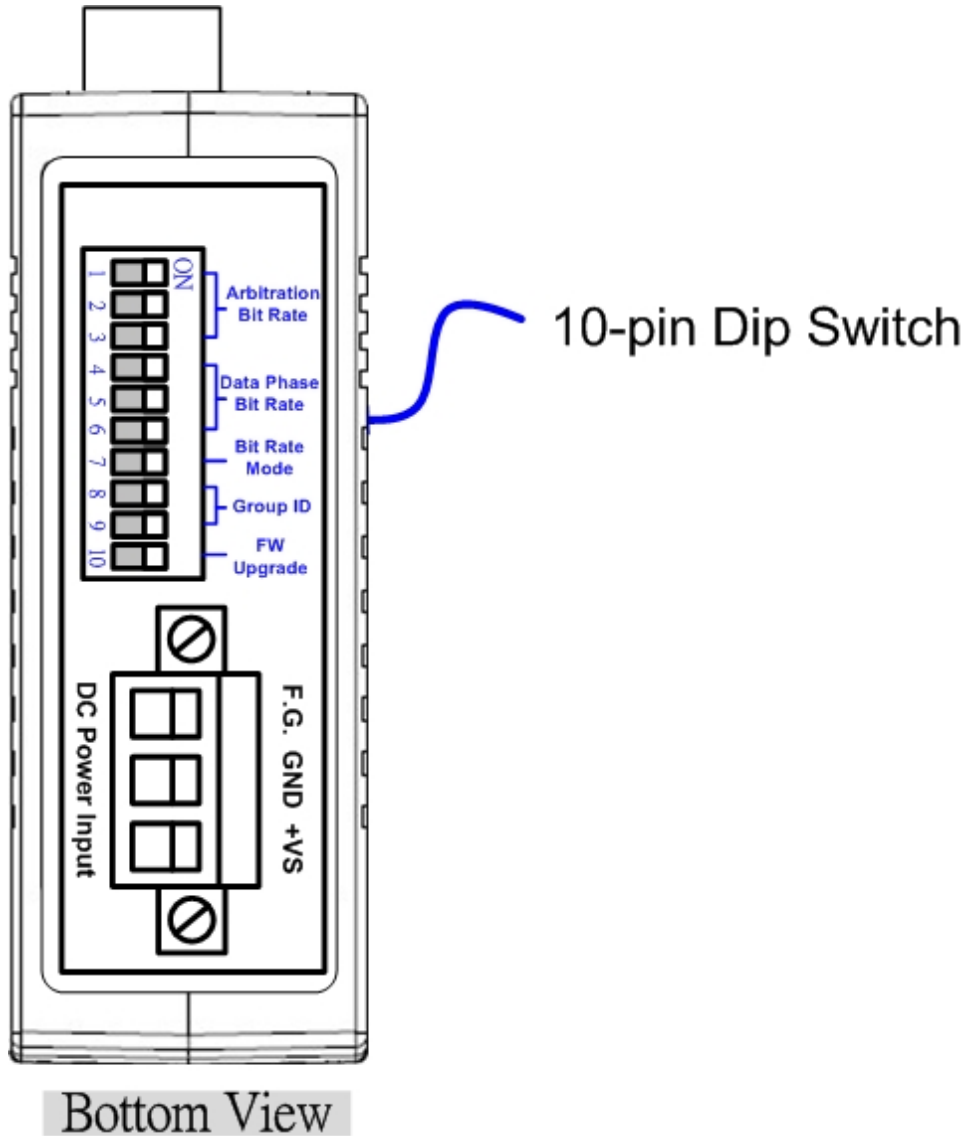
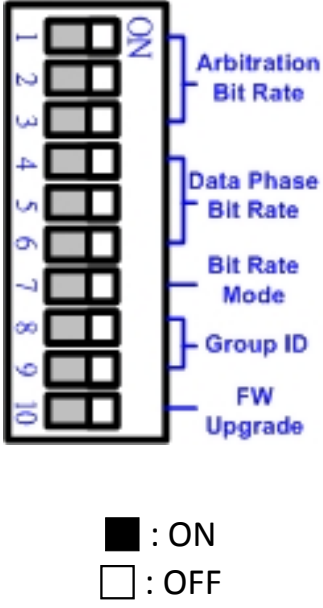

Figure 2-4-1 Location of 10-pin Dip Switch

About the function of the 10-pin dip switch, they are described on the following table.

Table 2-4-1 Description of 10-pin Dip Switch

10-pin dip switch	Pin	Switch Function	Description			
	1 ~ 3	Arbitration Bit Rate of CAN/CAN FD message	<b>Bit Rate (kbps)</b>	<b>1</b>	<b>2</b>	<b>3</b>
			10	<input type="checkbox"/>	<input type="checkbox"/>	<input type="checkbox"/>
			20	<input checked="" type="checkbox"/>	<input type="checkbox"/>	<input type="checkbox"/>
			50	<input type="checkbox"/>	<input checked="" type="checkbox"/>	<input type="checkbox"/>
			125	<input checked="" type="checkbox"/>	<input checked="" type="checkbox"/>	<input type="checkbox"/>
			250	<input type="checkbox"/>	<input type="checkbox"/>	<input checked="" type="checkbox"/>
			500	<input checked="" type="checkbox"/>	<input type="checkbox"/>	<input checked="" type="checkbox"/>
			800	<input type="checkbox"/>	<input checked="" type="checkbox"/>	<input checked="" type="checkbox"/>
			1000	<input checked="" type="checkbox"/>	<input checked="" type="checkbox"/>	<input checked="" type="checkbox"/>
	4 ~ 6	Data Phase Bit Rate of CAN FD message	<b>Bit Rate (kbps)</b>	<b>4</b>	<b>5</b>	<b>6</b>
			100	<input type="checkbox"/>	<input type="checkbox"/>	<input type="checkbox"/>
			125	<input checked="" type="checkbox"/>	<input type="checkbox"/>	<input type="checkbox"/>
			250	<input type="checkbox"/>	<input checked="" type="checkbox"/>	<input type="checkbox"/>
500			<input checked="" type="checkbox"/>	<input checked="" type="checkbox"/>	<input type="checkbox"/>	
800			<input type="checkbox"/>	<input type="checkbox"/>	<input checked="" type="checkbox"/>	
1000			<input checked="" type="checkbox"/>	<input type="checkbox"/>	<input checked="" type="checkbox"/>	
7	Bit Rate Mode	<b>ON:</b> Use Arbitration/ Data Phase bit rate setting by Utility configuration				
		<b>OFF:</b> Use Arbitration/ Data Phase bit rate setting by dip switch setting				
8 ~ 9	Module's group ID	<b>Group ID value</b>	<b>8</b>	<b>9</b>		
		00	<input type="checkbox"/>	<input type="checkbox"/>		
		01	<input checked="" type="checkbox"/>	<input type="checkbox"/>		
		02	<input type="checkbox"/>	<input checked="" type="checkbox"/>		
10	Firmware upgrade mode	<b>ON:</b> Into firmware upgrade mode.				
		<b>OFF:</b> Into normal operating mode.				

## 2.5. LED Indicator

There are 6 LEDs on the I-2533T-FD. One for power indication, two for fiber indication and three for CAN bus indication. The LED assignment and description are shown as follows.



Figure 2-5-1 LED Assignment of I-2533T-FD

Table 2-5-1 LED Description

LED Name	Color	Description
PWR	Red	When power on the I-2533T-FD, this LED is turned on.
FB_Ack	Green	When the I-2533T-FD sends/receives one message to/from the fiber, this LED flashes once.
FB_Err	Orange	If the I-2533T-FD detects the RXD line of the fiber is off, this LED is always on.
CAN_Err	Red	<ol style="list-style-type: none"> <li>1. If the I-2533T-FD detects the bus-off status on the CAN bus, this LED is always on.</li> <li>2. If the CAN data buffer is full, this LED flashes once per second.</li> <li>3. If the I-2533T-FD can't send CAN/CAN FD messages successfully because the bus connector is off or some errors happen, this LED flashes five times per second.</li> </ol>
CAN_Tx	Green	When the I-2533T-FD transmits one CAN/CAN FD message to CAN bus, this LED flashes once.
CAN_Rx	Green	When the I-2533T-FD receives one CAN/CAN FD message from CAN bus, this LED flashes once.

**NOTE:**

In “Firmware Upgrade Mode”, the CAN\_Err, CAN\_Tx, CAN\_Rx and FB\_Err LEDs will flash per 500 milliseconds.



## 2.6. Terminal Resistor Setup

In order to minimize the reflection effects on the CAN bus line, the CAN bus line has to be terminated at both ends by two terminal resistors as in the following figure. According to the ISO 11898-2 spec, each terminal resistor is 120Ω (or between 108Ω~132Ω). The bus topology and the positions of these terminal resistors are shown as following figure.

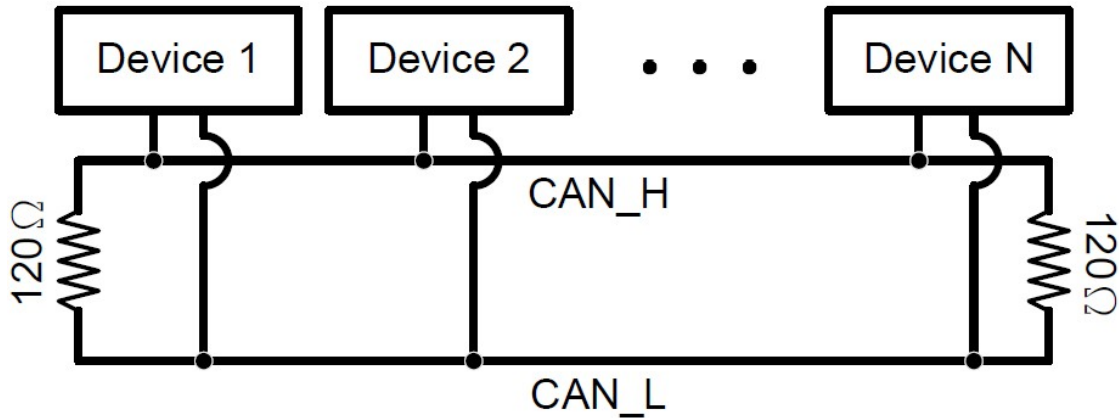

Figure 2-6-1 CAN bus network topology

Each I-2533T-FD includes one build-in 120Ω terminal resistor, users can decide to enable it or not. The DIP switch for terminal resistor is on the upper of the CAN connector.

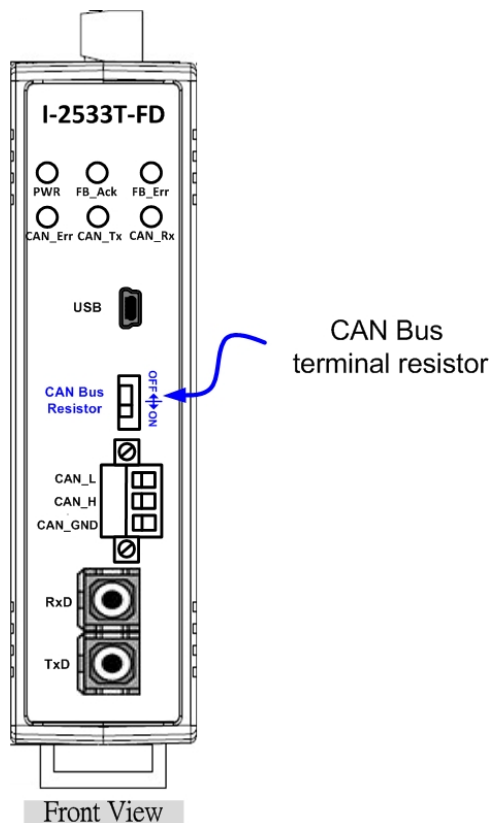

Figure 2-6-2 Location of Terminal resistor DIP Switch

The following DIP switch statuses present the condition if the terminal resistor is active (default) or inactive.

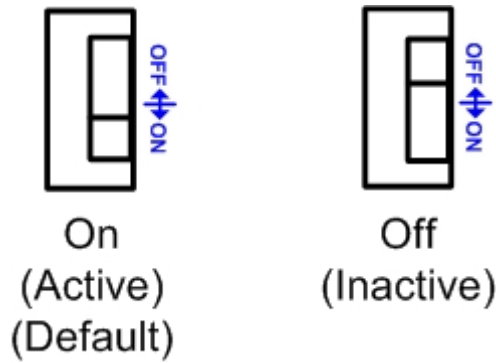

Figure 2-6-3 Adjustment of Terminal Resistance

Generally, if your application is as follows, we recommend you to enable the terminal resistor.

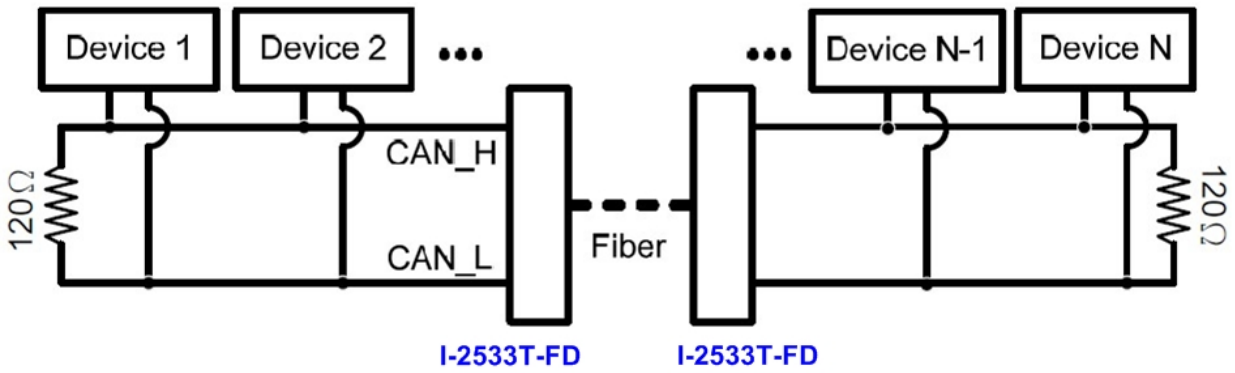

Figure 2-6-4 Application 1

If your application is like the structure as follows, the terminal resistor is not needed.

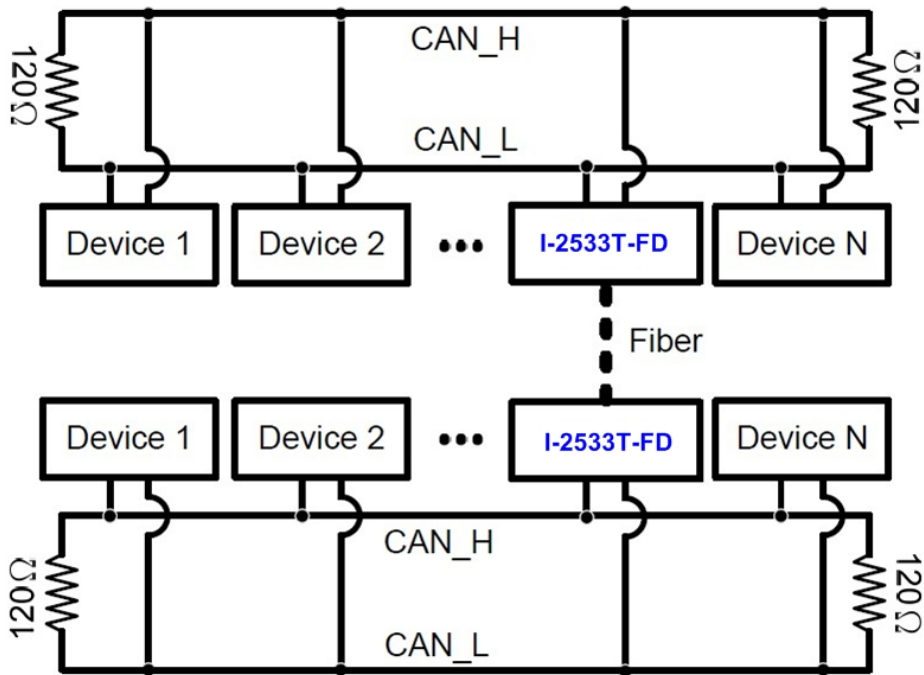
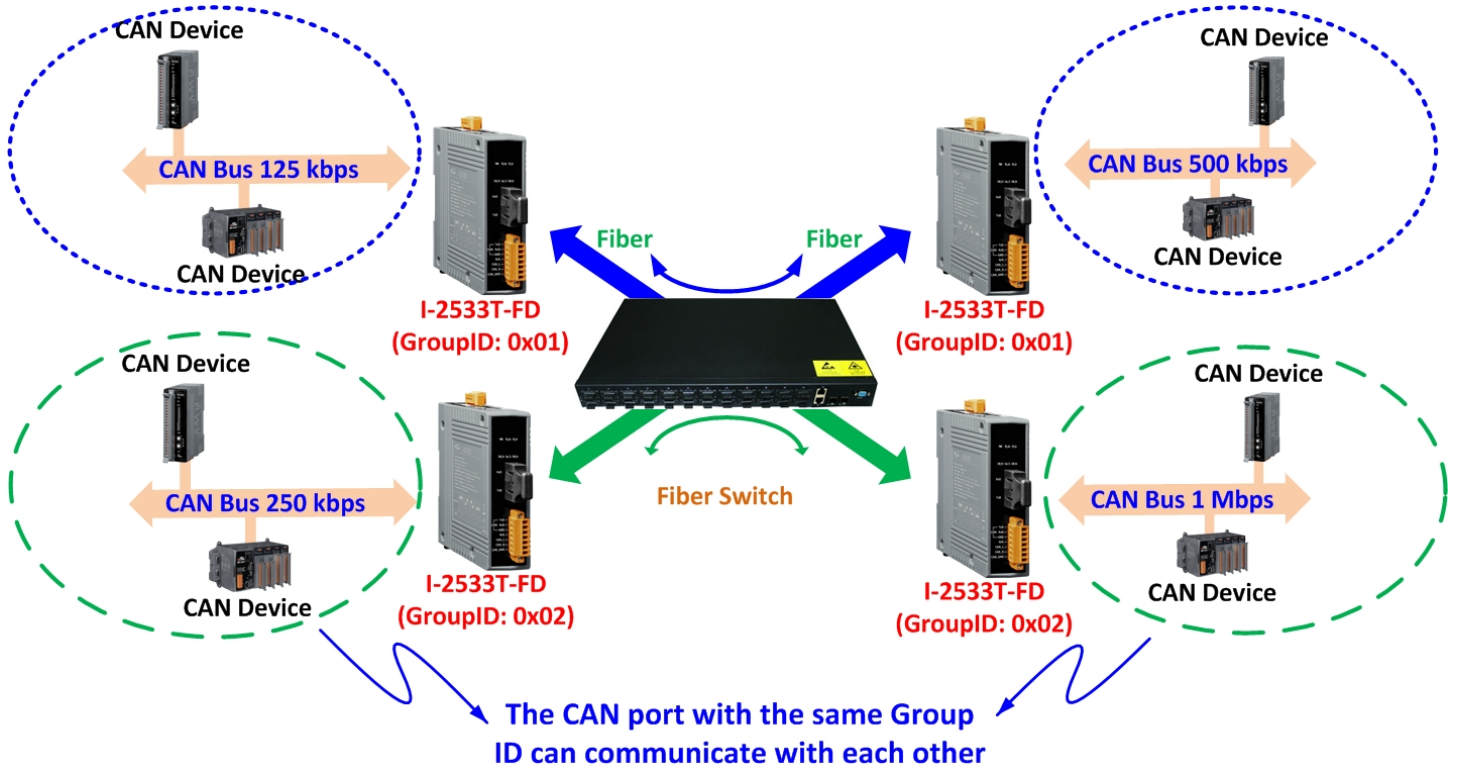

Figure 2-6-5 Application 2

## 2.7. Module Group ID

The CAN port with the same “Group ID” setting can communicate with each other via fiber optics. This setting is used for I-2533T-FD to communicate with the others modules on star topology application.



Users can decide the value from 0 to 3 via pin 8 ~ 9 on 10-pin dip switch. The dip switch for “Group ID” is over the power connector.

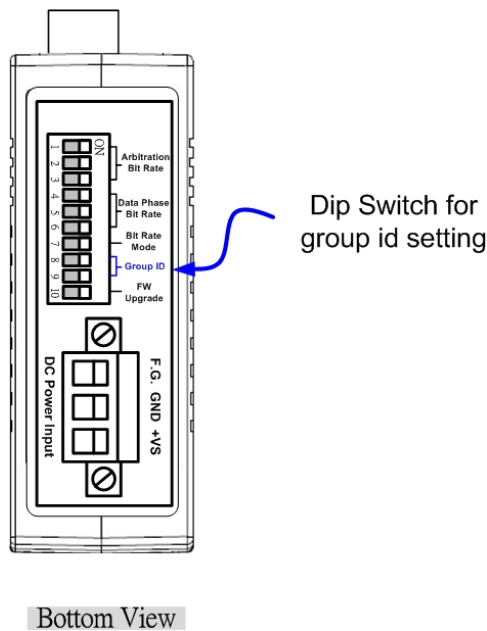

Figure 2-7-1 Location of Group ID DIP Switch

The following DIP switch statuses present the “Module Group ID” value.

Table 2-7-1 Group ID Description

10-pin dip switch	Pin	Switch Function	Description															
	8 ~ 9	Module's group ID	<table border="1"> <thead> <tr> <th>Group ID value</th> <th>8</th> <th>9</th> </tr> </thead> <tbody> <tr> <td>00</td> <td><input type="checkbox"/></td> <td><input type="checkbox"/></td> </tr> <tr> <td>01</td> <td><input checked="" type="checkbox"/></td> <td><input type="checkbox"/></td> </tr> <tr> <td>02</td> <td><input type="checkbox"/></td> <td><input checked="" type="checkbox"/></td> </tr> <tr> <td>03</td> <td><input checked="" type="checkbox"/></td> <td><input checked="" type="checkbox"/></td> </tr> </tbody> </table>	Group ID value	8	9	00	<input type="checkbox"/>	<input type="checkbox"/>	01	<input checked="" type="checkbox"/>	<input type="checkbox"/>	02	<input type="checkbox"/>	<input checked="" type="checkbox"/>	03	<input checked="" type="checkbox"/>	<input checked="" type="checkbox"/>
Group ID value	8	9																
00	<input type="checkbox"/>	<input type="checkbox"/>																
01	<input checked="" type="checkbox"/>	<input type="checkbox"/>																
02	<input type="checkbox"/>	<input checked="" type="checkbox"/>																
03	<input checked="" type="checkbox"/>	<input checked="" type="checkbox"/>																

The following “Module Group ID” values of device A and B present these ID are in the same group which can communicate with each other.

Table 2-7-2 Group of “Module Group ID”

Items	Device A Group ID value	Device B Group ID value
1	00	00
2	01	01 or 03
3	02	02 or 03
4	03	01 or 02 or 03

For example, there are three CAN networks, Network A, Network B and Network C, and each of them uses one I-2533T-FD. The Group IDs of the I-2533T-FDs are 1, 2, and 3 respectively. The Network A can exchange the data with Network C because the Group IDs of the I-2533T-FDs are in the same group (the second rule in the above table). The Network B can exchange the data with Network C, which follows the third rule in the above table. The Network A can't connect with the Network B because these two I-2533T-FDs are not in the same group.

## 2.8. Wire Connection

The wire connection of the I-2533T-FD is displayed below.

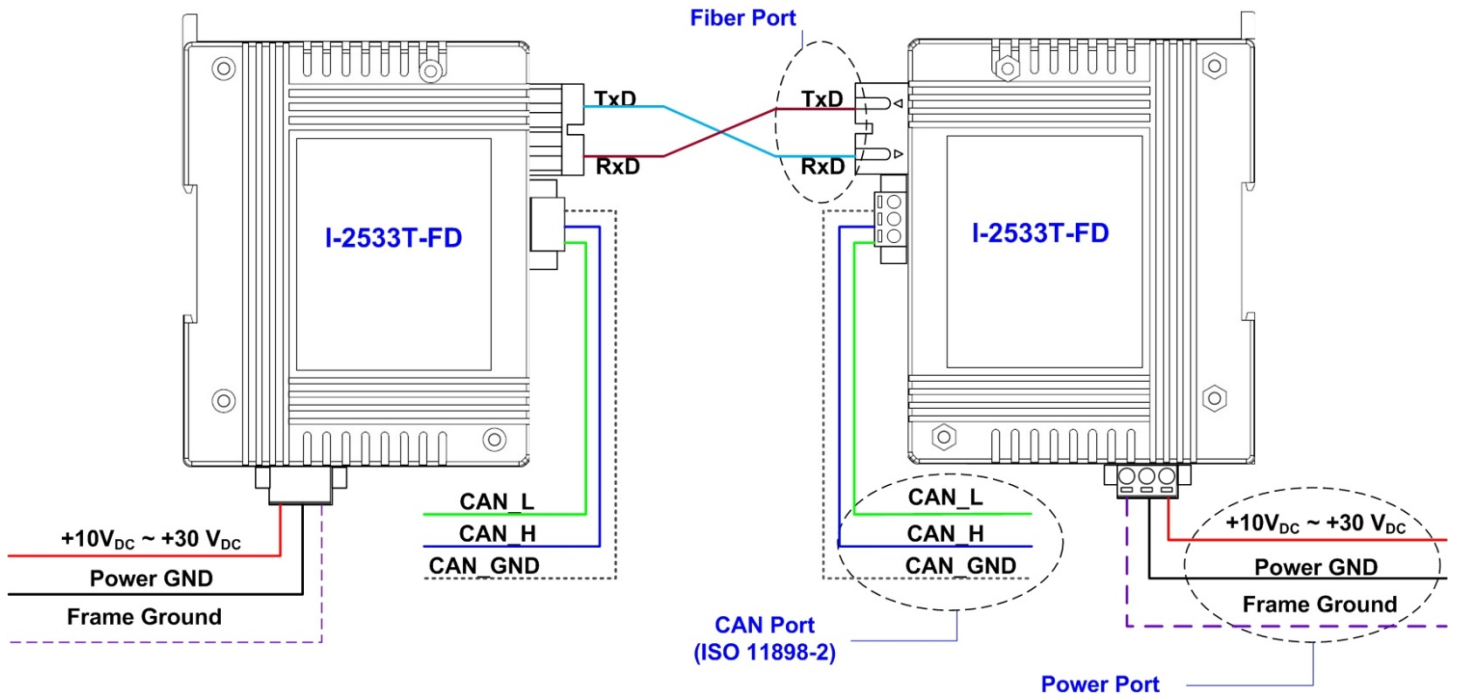

Figure 2-8-1 Wire Connection for I-2533T-FD

# 3. Network Deployment

## 3.1. Driving Capability

Before introducing the driving capability of the I-2533T-FD, some characteristics of copper cable must be assumed. The AC parameters are 120Ω impedance and 5ms/, line delay, and the DC parameter follows the table show below.

Table 3-1-1 Recommended DC parameter for CAN Bus Line

Wire Cross-Section [mm <sup>2</sup> ]	Resistance [Ω/km]
~0.25 (AWG23)	< 90
~0.5 (AWG20)	< 50
~0.8 (AWG18)	< 33
~1.3 (AWG16)	< 20

Under the condition described above, users can refer to the following table to know the maximum node number in each segment following ISO 11898-2 and the maximum segment length when using different type of wire.

Table 3-1-2 Driving Capability

Wire Cross-Section [mm <sup>2</sup> ]	The maximum segment length [m] under the case of specific node number in this segment			
	16 Nodes	32 Nodes	64 Nodes	100 Nodes
~0.25 (AWG23)	< 220	< 200	< 170	< 150
~0.5 (AWG20)	< 390	< 360	< 310	< 270
~0.8 (AWG18)	< 590	< 550	< 470	< 410
~1.3 (AWG16)	< 980	< 900	< 780	< 670

## 3.2. Fiber Selection & Fiber Length

The specification of fiber cable used to connect the I-2533T-FD is shown as following table.

Table 3-2-1 Specification of Fiber

Type	Diameter [ $\mu\text{m}$ ] (Core/Cladding)	Operating Wavelength [nm]
Multi-mode	50/125, 62.5/125 or 100/140 (62.5/125 recommended)	1310

The I-2533T-FD allows maximum 2km fiber length for each kind of CAN baud theoretically. Although the maximum fiber length has no relationship with the CAN baud rate, but some fiber attributions, such as attenuation, still influence it. Higher attenuation of fiber will reduce the transmission distance. User can use following table to know the relationship between those two.

Table 3-2-2 The relationship between CAN baud rate and theoretical Fiber length

Module Name	Arbitration bit rate (bps)	Data Phase bit rate (bps)	Allowed Fiber length [km]
I-2533T-FD	10 k ~ 1M	100 k ~ 10M	2

Table 3-2-3 Fiber Attenuation & Fiber Length

Module Name	Fiber Attenuation [dB/km]	Allowed Fiber length [km]
I-2533T-FD	3.5	2
	> 3.5	< 2

## 4. Software Utility

When users want to use user-defined CAN/CAN FD baud rate and CAN/CAN FD message filter on the I-2533T-FD, the “I-2533CS-FD Utility” tool may be needed.

### 4.1. Install the I-2533CS-FD Utility

Step 1: Get the I-2533CS-FD Utility

The software is located at:

<https://www.icpdas.com/en/download/show.php?num=2454&model=I-2533T-FD>

Step 2: Install .NET Framework 3.5 component

The I-2533CS-FD Utility tool requires the .NET Framework 3.5 components. After executing the “Setup.msi” file, it will start to install .NET Framework 3.5 components.

Step 3: Install Utility tool

After installing the .Net Framework components, the software will continue to install the Utility tool.

1. Click the “Next” button to continue.

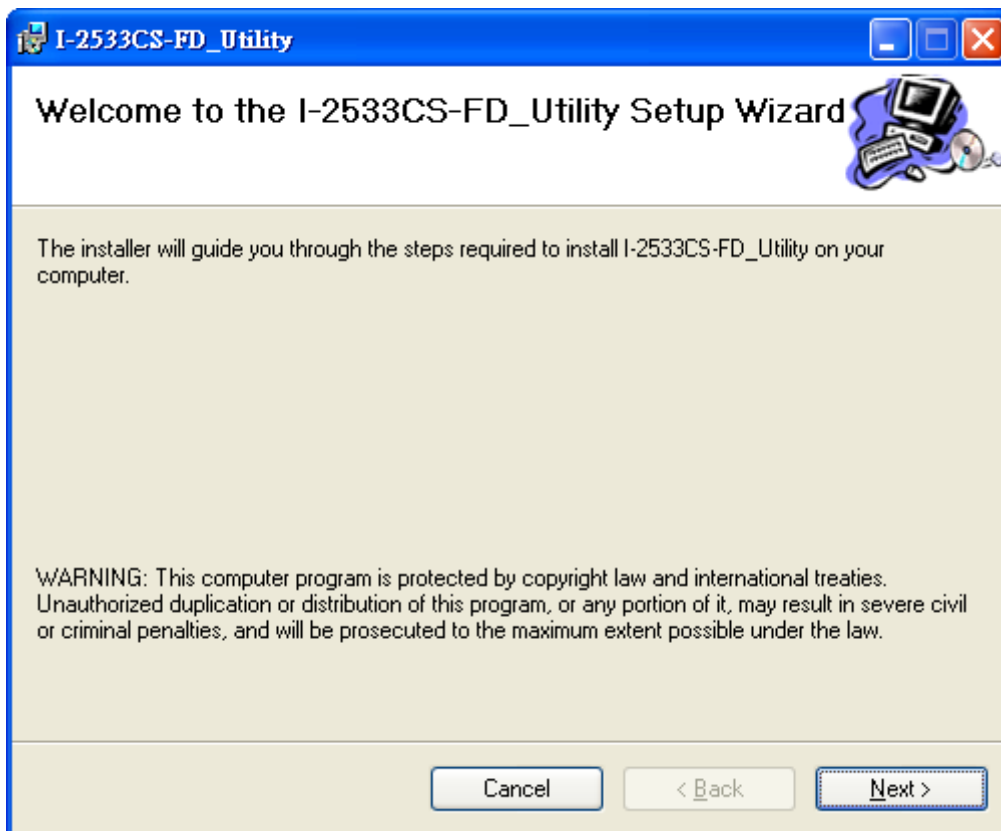



2. Select the installation path of the I-2533CS-FD Utility and click the “Next” button.

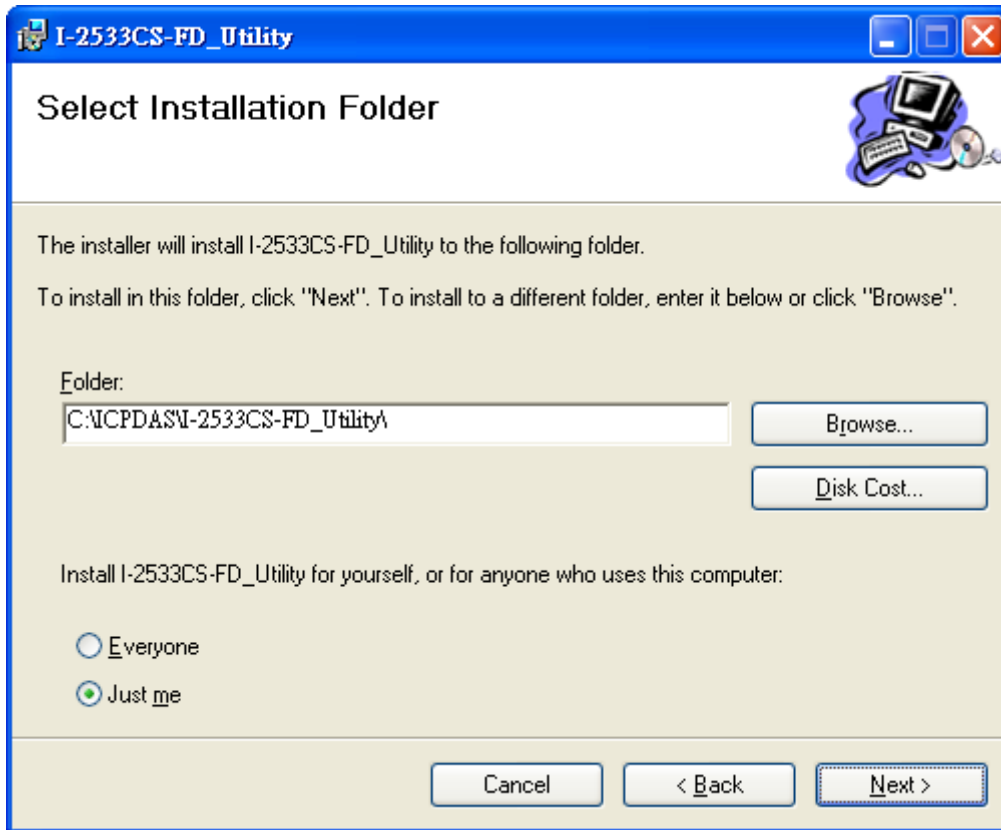

3. Confirm the installation. Click the “Next” button to start the installation

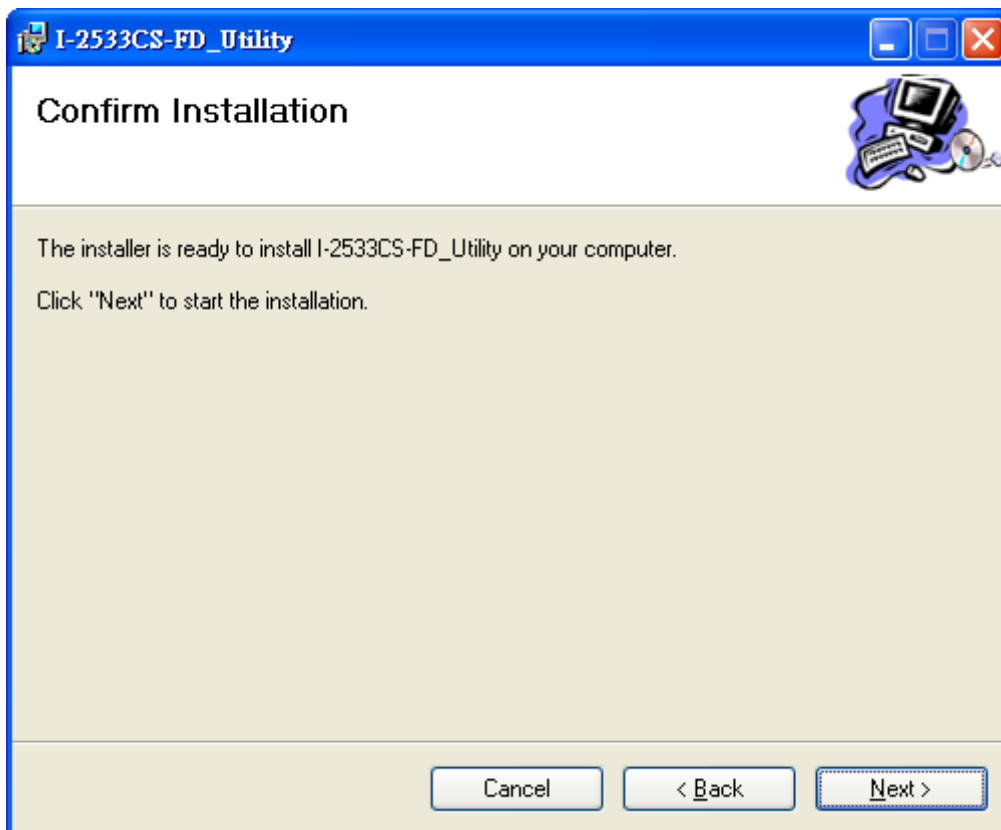

4. Installation complete. Click the “Close” button to exit

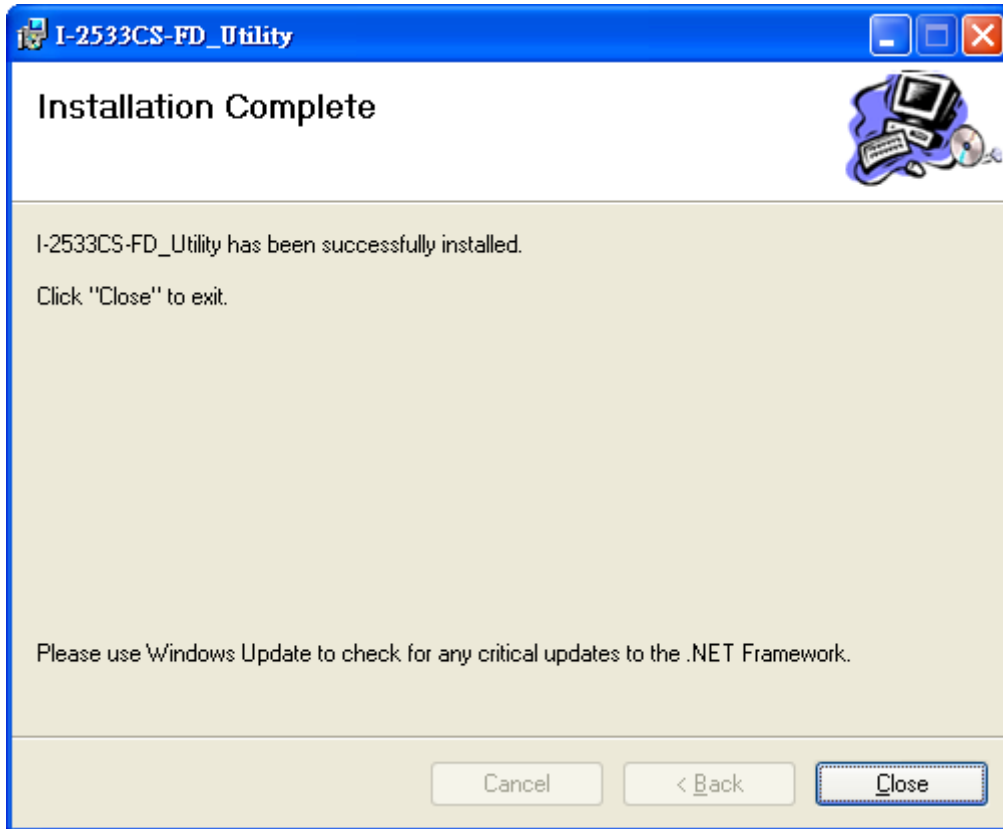

## 4.2. Setting up the I-2533T-FD

After installing the utility tool, please follow the following steps to set up the communication between the Utility and the I-2533T-FD. Here is the example for the I-2533T-FD configuration.

Step 1: Connect the PC available USB port with the USB port of the I-2533T-FD. Users can find the communication cable (CA-USB10) in the product box.

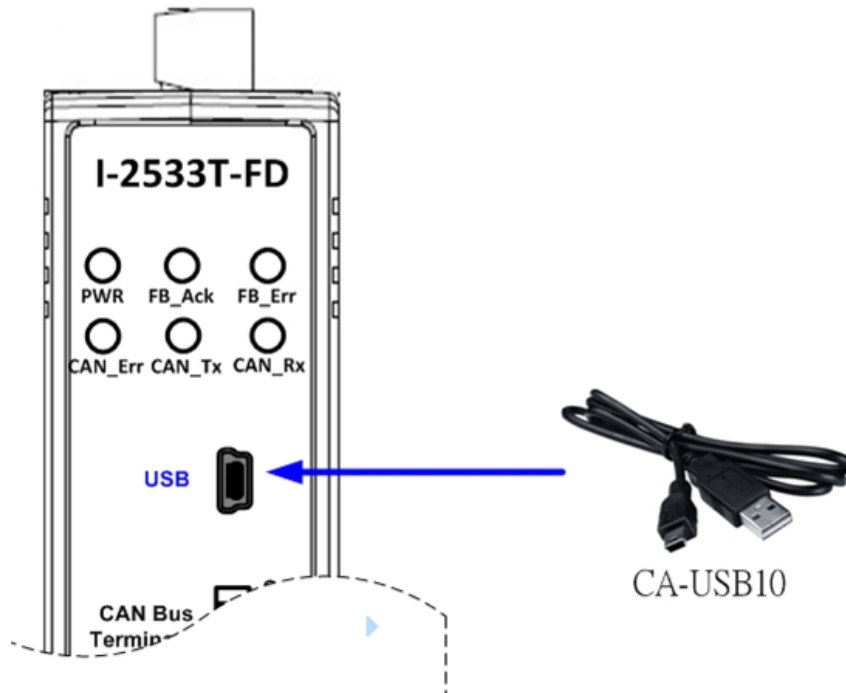

Figure 4-2-1 Wire connection of the USB port

Step 2: Execute the I-2533CS-FD Utility tool.

## 4.3. Start to use I-2533CS-FD Utility tool

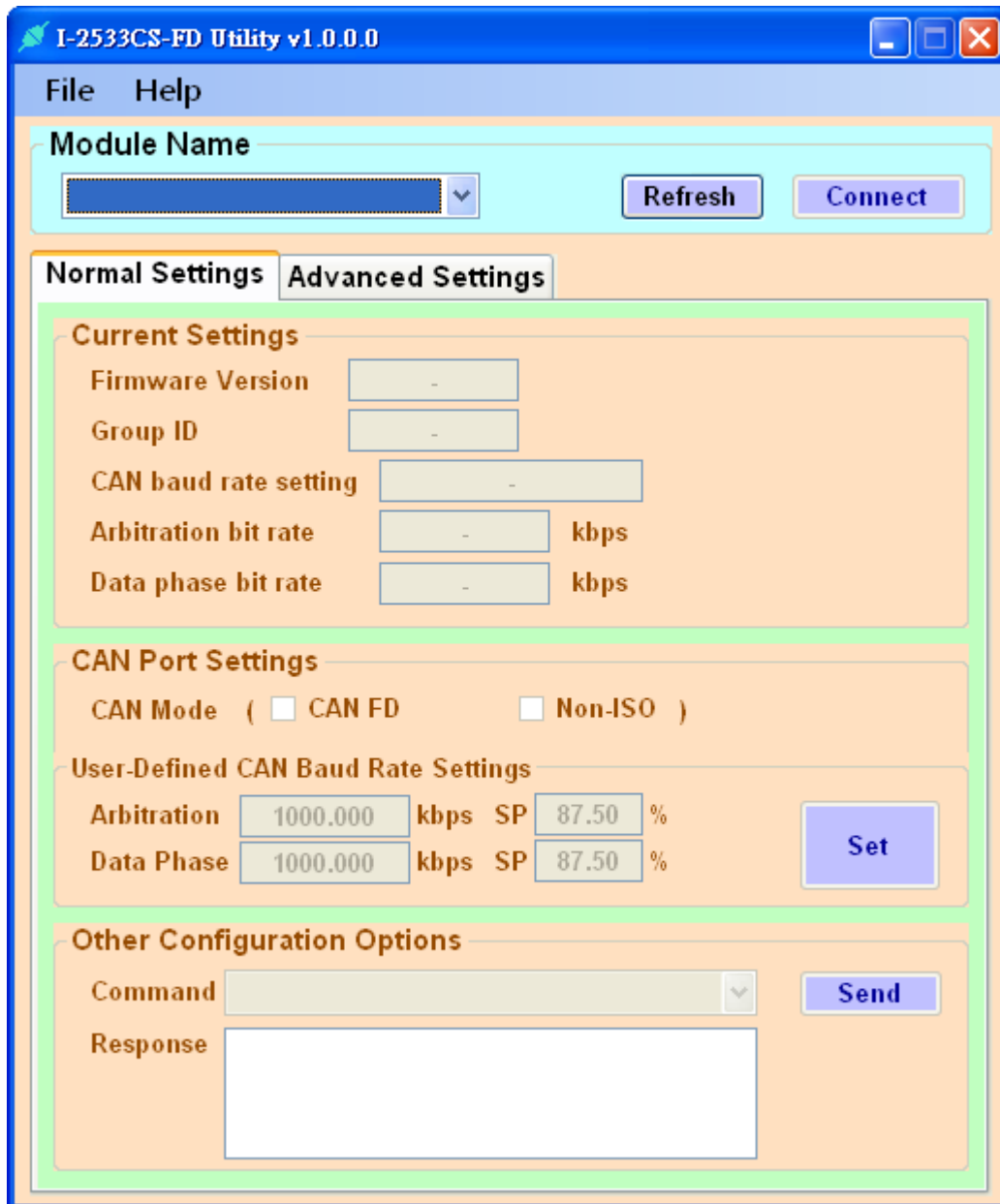

Figure 4-3-1 Main frame of the I-2533CS-FD Utility tool

### [Normal Settings]

This field is used to get the current module settings, set user-defined CAN/CAN FD baudrate and configure other parameters.

### [Advanced Settings]

This field is used to configure the CAN ID filter of the module.

## 4.3.1. Connect to the module

Press the “Refresh” button to scan and list all the necessary I-2533T-FD modules on “Module Name” location.

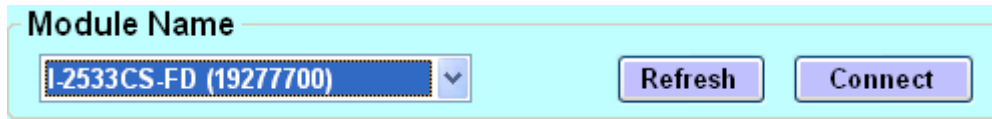

The screenshot shows a light blue header with the text "Module Name". Below the header is a dropdown menu with the selected item "I-2533CS-FD (19277700)". To the right of the dropdown are two buttons: "Refresh" and "Connect".

Then select the necessary I-2533T-FD module and press “Connect” button to start to connect with it.

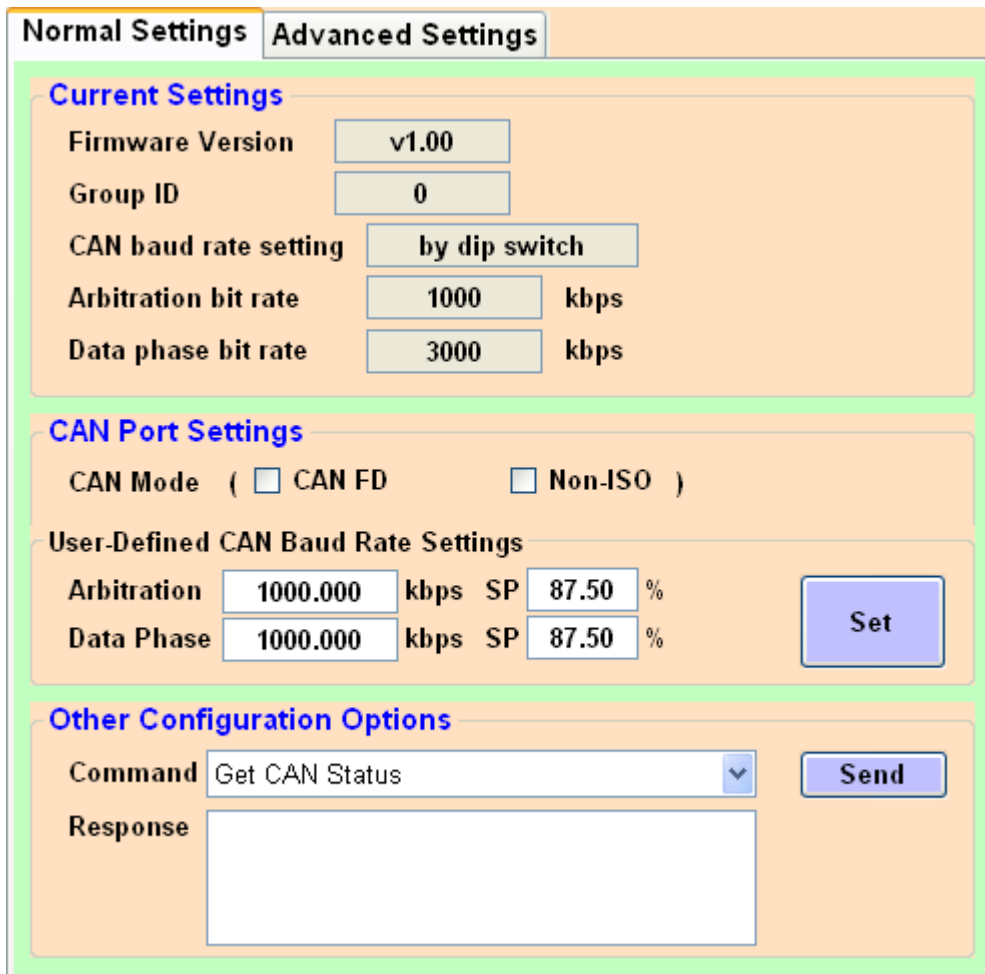

The screenshot shows the "Advanced Settings" tab of a configuration interface. It is divided into three sections:

- Current Settings:** Contains input fields for "Firmware Version" (v1.00), "Group ID" (0), "CAN baud rate setting" (by dip switch), "Arbitration bit rate" (1000 kbps), and "Data phase bit rate" (3000 kbps).
- CAN Port Settings:** Includes "CAN Mode" with radio buttons for "CAN FD" and "Non-ISO". Below it is the "User-Defined CAN Baud Rate Settings" section with input fields for "Arbitration" (1000.000 kbps SP 87.50 %) and "Data Phase" (1000.000 kbps SP 87.50 %), and a "Set" button.
- Other Configuration Options:** Features a "Command" dropdown menu (set to "Get CAN Status") and a "Send" button. Below the command field is a large empty text area labeled "Response".

## 4.3.2. Get Current Module Settings

After successfully connect with the module, the current settings of module will be listed on “Current Settings” frame.

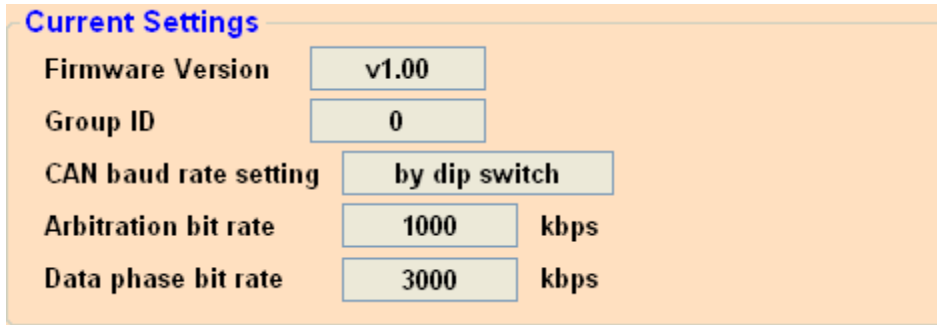

The screenshot shows a window titled "Current Settings" with a light orange background. It contains five rows of settings, each with a label on the left and a value in a text box on the right. The values are: v1.00 for Firmware Version, 0 for Group ID, by dip switch for CAN baud rate setting, 1000 kbps for Arbitration bit rate, and 3000 kbps for Data phase bit rate.

Setting	Value
Firmware Version	v1.00
Group ID	0
CAN baud rate setting	by dip switch
Arbitration bit rate	1000 kbps
Data phase bit rate	3000 kbps

### [Current Settings]

“**Firmware Version**”: Firmware version of the I-2533T-FD module.

“**Group ID**”: Group ID setting of the I-2533T-FD module.

“**CAN baud rate setting**”: Current CAN baudrate setting that the I-2533T-FD module used.

“**Arbitration bit rate**”: Current CAN/CAN FD arbitration phase bit rate the I-2533T-FD module used.

“**Data phase bit rate**”: Current CAN FD data phase bit rate the I-2533T-FD module used.

### 4.3.3. Configure User-Defined CAN Baudrate

User also can set the CAN port operation mode and user-defined CAN baudrate parameter of the module. In order to use the “User-Defined CAN Baud Rate Settings” parameters, user need to set the pin7 of “10-pin dip switch” to ON position. Otherwise, the “Arbitration Bit Rate” and “Data Phase Bit Rate” settings will follow according to “10-pin dip switch” settings.

**CAN Port Settings**

CAN Mode (  CAN FD  Non-ISO )

**User-Defined CAN Baud Rate Settings**

Arbitration	<input type="text" value="1000.000"/>	kbps	SP	<input type="text" value="87.50"/>	%
Data Phase	<input type="text" value="1000.000"/>	kbps	SP	<input type="text" value="87.50"/>	%

Users can set parameters such as CAN port operation mode and CAN communication baud rate in the "CAN Port Settings" field. All settings will take effect after reboot the module. The detailed functions are as follows:

#### [CAN Mode]

“CAN FD” :

Set the CAN port into CAN FD mode. When setting the CAN port into CAN FD mode, the CAN port can process CAN/CAN FD messages, otherwise this port just can process CAN messages.

“Non-ISO”:

Non-ISO operation. If this parameter is checked, the module uses the CAN FD frame format as specified by the Bosch CAN FD Specification V1.0. Otherwise, CAN FD frame format will follow according to ISO11898-1.

#### [User-defined CAN Baud Rate Settings]

“Arbitration”:  
CAN/CAN FD arbitration phase bit rate. Valid range: 10 kbps ~ 1000 kbps.

“Data Phase”:  
CAN FD data phase bit rate. Valid range: 100 kbps ~ 10000 kbps

“SP”:  
CAN/CAN FD arbitration/data phase bit rate sample point.  
Suggested range: 75.00 ~ 87.50 %

## 4.3.4. Configure Other Parameters

From the “Configuration Options” block, user can get the module CAN status (CAN Bus status, Error counter, and buffer status), CAN Rx FPS(received CAN message frame per second) and reset the module.

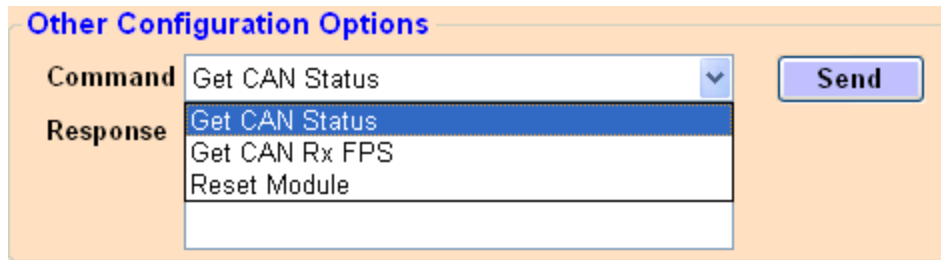

[Get CAN Status] command:

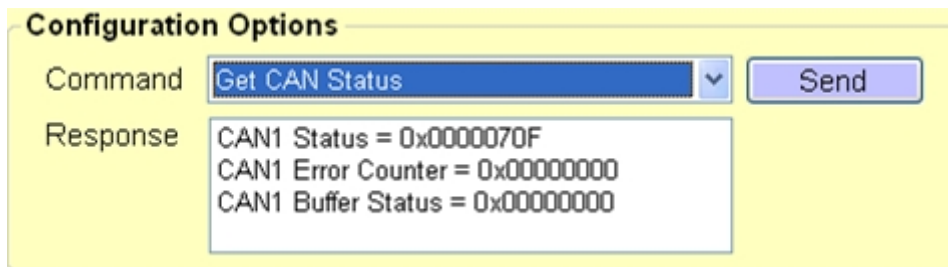

- <1> **“CAN Status”** item:  
0x: value in hexadecimal format.  
Please refer to appendix 6.3 for “CAN Status” definition.
- <2> **“CAN Error Counter”** item:  
0x: value in hexadecimal format.  
Please refer to appendix 6.4 for “CAN Error Counter” definition.
- <3> **“CAN Buffer Status”** item:  
0x: value in hexadecimal format.

Bit	Symbol	Value	Description
0	RX		CAN receive software buffer status
		0	Receive software buffer underrun
		1	Receive software buffer overrun
1	TX		CAN transmit software buffer status
		0	Transmit software buffer underrun
		1	Transmit software buffer overrun
3:2	-		Reserved
4	EW		CAN Error Warning status.
		0	Both error counters are below the Error_Warning limit of 96
		1	At least one of error counter has reached the Error_Warning limit of 96



5	EP		CAN Error passive status
		0	The CAN is in Error_Active state.
		1	The CAN is in the Error_Passive state
6	BO		CAN Bus Off status
		0	The CAN is not in Bus_OFF state.
		1	The CAN is in the Bus_OFF state
31:7	-	-	Reserved

**[Get CAN Rx FPS]** command:

**Configuration Options**

Command: Get CAN Rx FPS Send

Response: CAN1 Rx FPS = 740

<1> **“CAN Rx FPS”** item:  
CAN received CAN message frame per second.

**[Reset Module]** command:

Reset the module.

## 4.3.5. Configure CAN ID Filter

By using the I-2533CS-FD Utility tool, user can configure the CAN ID filter of the module.

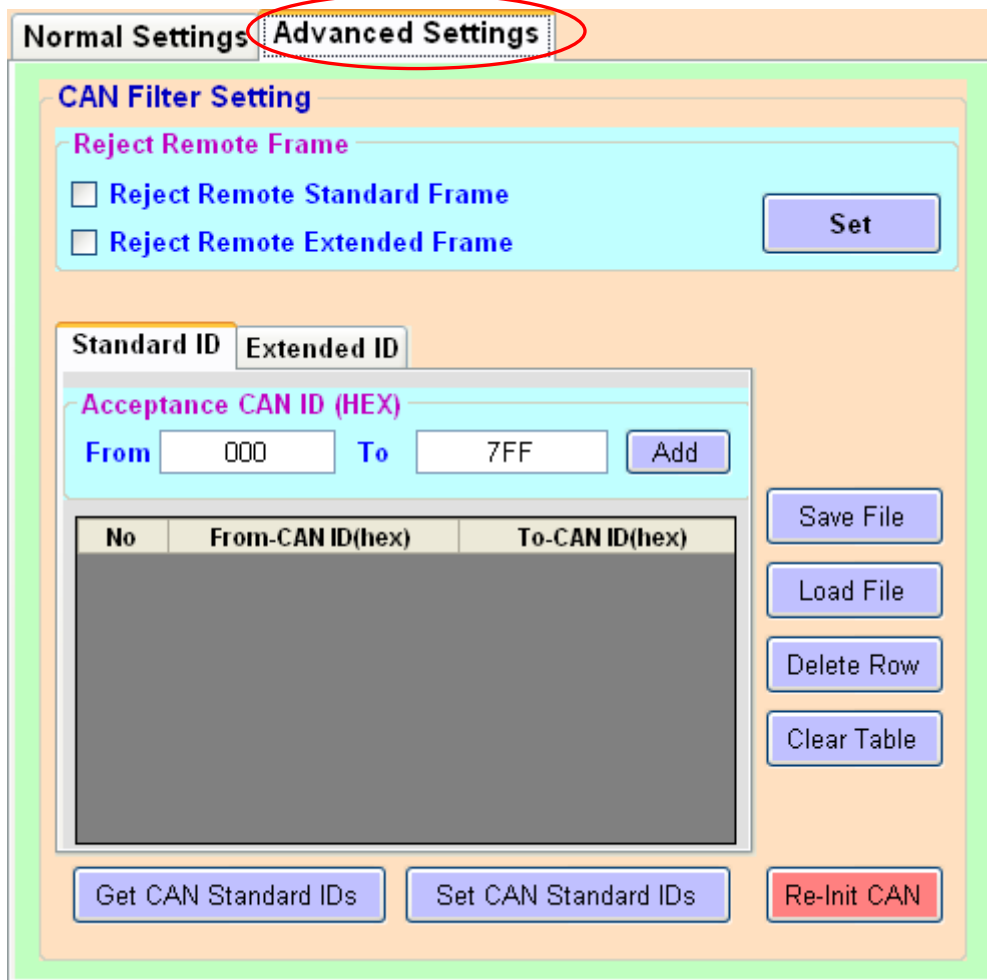

The “Reject Remote Frame” is used to reject remote standard/extended CAN frame. And the “Standard ID/Extended ID” field are used to set accepted standard/extended CAN IDs. All settings in the “CAN Filter Setting” will take effect after pressing “Re-Init CAN” button.

**[Reject Remote Frame] block:**

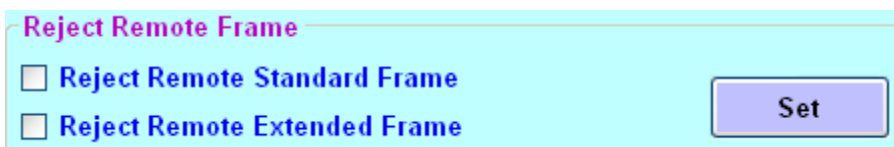

<1> “Set” button:

Checking the “Reject Remote Standard/Extended Frame” item to select whether reject remote standard/extended CAN frame or not. After checking the “Reject Remote Frame”, press the “Set” button to save the setting into module.

## [Standard ID/Extended ID] block:

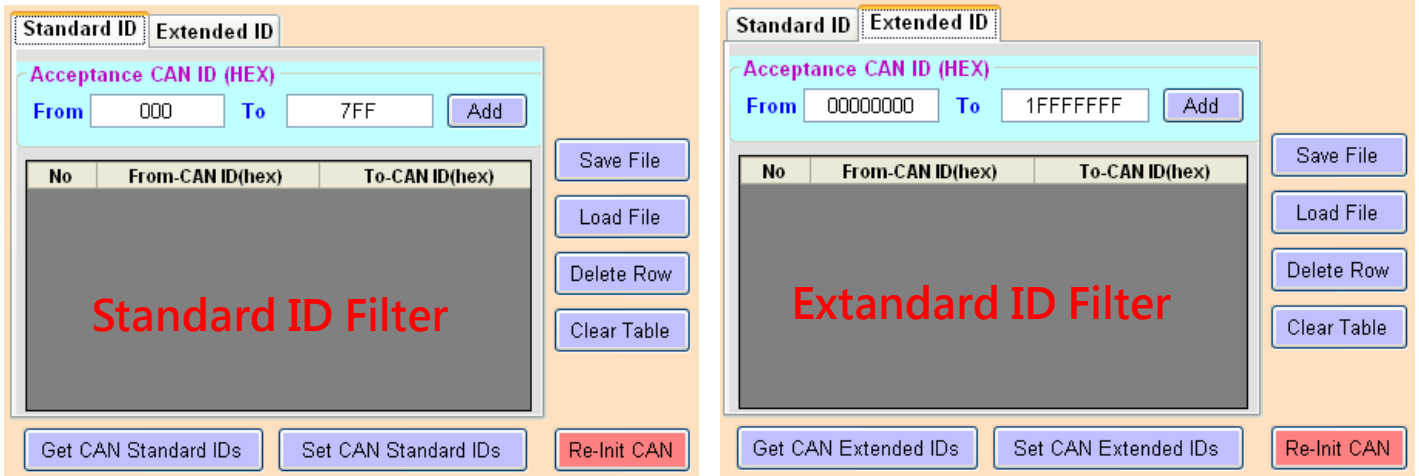

### “CAN ID (HEX)” block:

Press the “Add” button to add a range of standard/extended CAN ID into “Standard/Extended ID Fiter” frame.

- <1> **“Get CAN Standard IDs/Get CAN Extended IDs”** button:  
Get all the CAN Standard/Extended IDs setting from the module.
- <2> **“Set CAN Standard IDs/Set CAN Extended IDs”** button:  
Set the CAN Standard/Extended IDs setting on “Standard/Extended ID Fiter” frame into the module.
- <3> **“Re-Init CAN”** button:  
All settings in the “CAN Filter Setting” will take effect after pressing “Re-Init CAN” button.
- <4> **“Save File”** button:  
Save the CAN Standard/Extended IDs setting on “Standard/Extended ID Fiter” frame into an ini file.
- <5> **“Load File”** button:  
Load the CAN Standard/Extended IDs setting from a selected ini file to “Standard/Extended ID Fiter” frame.
- <6> **“Delete Row”** button:  
Delete a selected row CAN ID from “Standard/Extended ID Fiter” frame.
- <7> **“Clear Table”** button:  
Delete all CAN IDs from “Standard/Extended ID Fiter” frame.

# 5. Firmware Upgrade

Please refer to the following steps to upgrade the firmware of I-2533T-FD module.

Step 1: Power off the I-2533T-FD.

Step 2: Set the I-2533T-FD's pin 10 of 10-pin dip switch to 'ON' position.

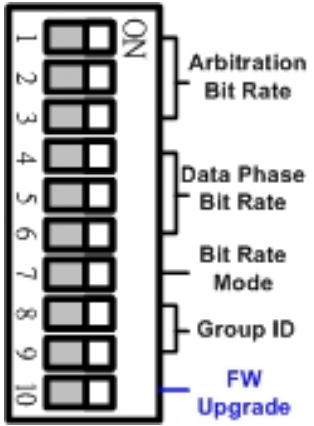
10-pin dip switch	Pin	Switch Function	Description
	10	Firmware upgrade mode	<b>ON:</b> Into firmware upgrade mode.  <b>OFF:</b> Into normal operating mode.

Step 3: Power on the I-2533T-FD, the CAN\_Err, CAN\_Tx, CAN\_Rx, FB\_Err LEDs will flash per 500 milliseconds.

Step 4: Connect the PC available USB port with the USB port of the I-2533T-FD. Users can find the communication cable (CA-USB10) in the product box.

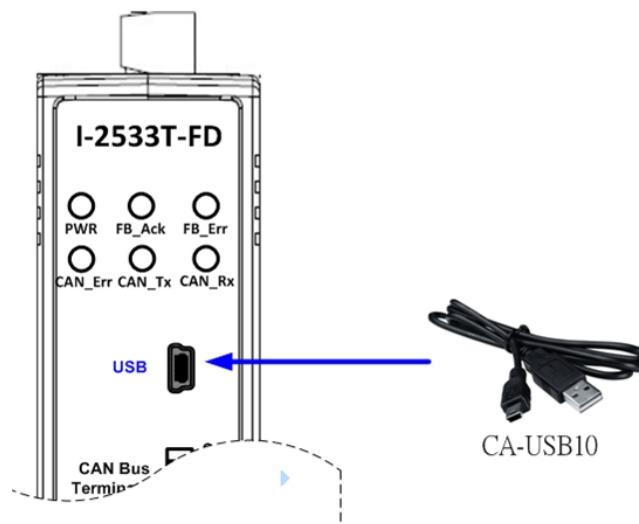

Figure 5-1-1 Wire connection of the USB

Step 5: At this time, the I-2533T-FD module will be simulated as a “USB Mass Storage Device”, and one more “USB Disk” window, will pop up on the PC side. Then users can upgrade the firmware of the I-2533T-FD module via this USB disk.

Step 6: Get the “Firmware Update Tool” and firmware file.

The “Firmware Update Tool” is located at:

<https://www.icpdas.com/en/download/show.php?num=3018&model=I-2533T-FD>

The firmware is located at:

<https://www.icpdas.com/en/download/show.php?num=2455&model=I-2533T-FD>

Step 7: Execute the “Firmware Update Tool”.

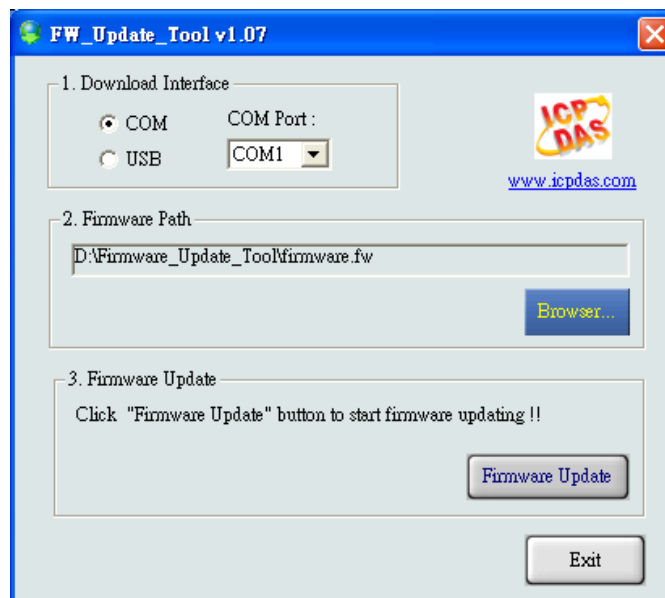

Step 8: Select USB port and the necessary USB Disk of PC

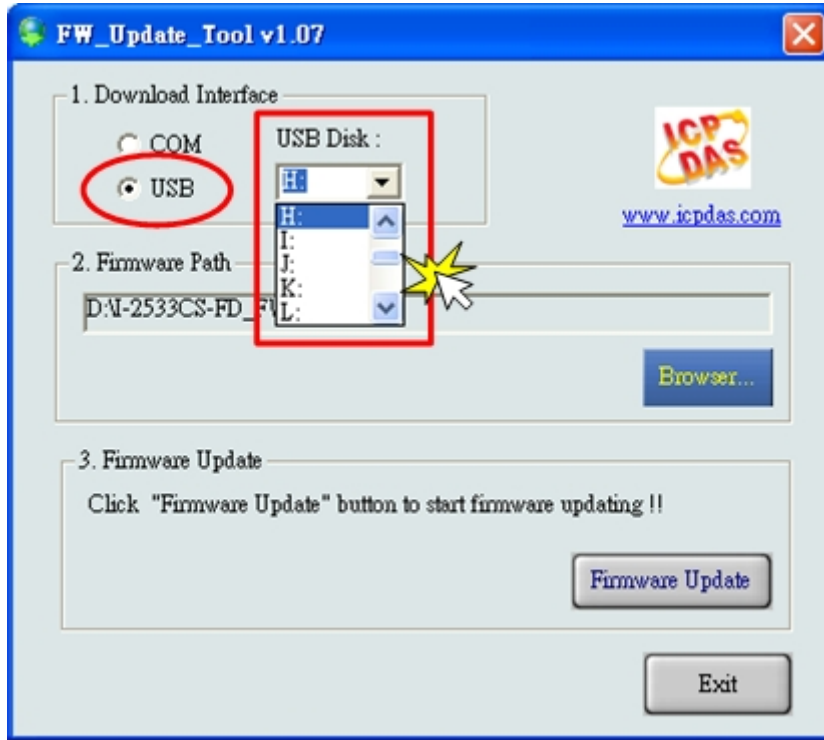

Step 9: Press the the “Browser...” button and select the firmware file (\*.fw).

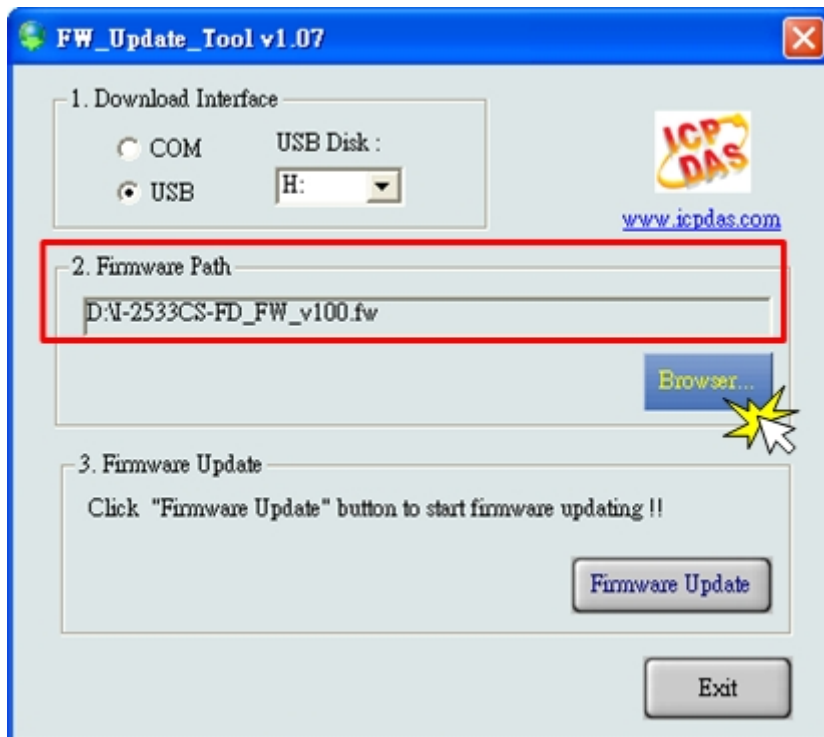

Step 10: Press the “Firmware Update” button to update the firmware. After successfully to update the firmware, the “Firmware Update Success! Please Reboot Module!” information will be display on the “3. Firmware Update” frame.

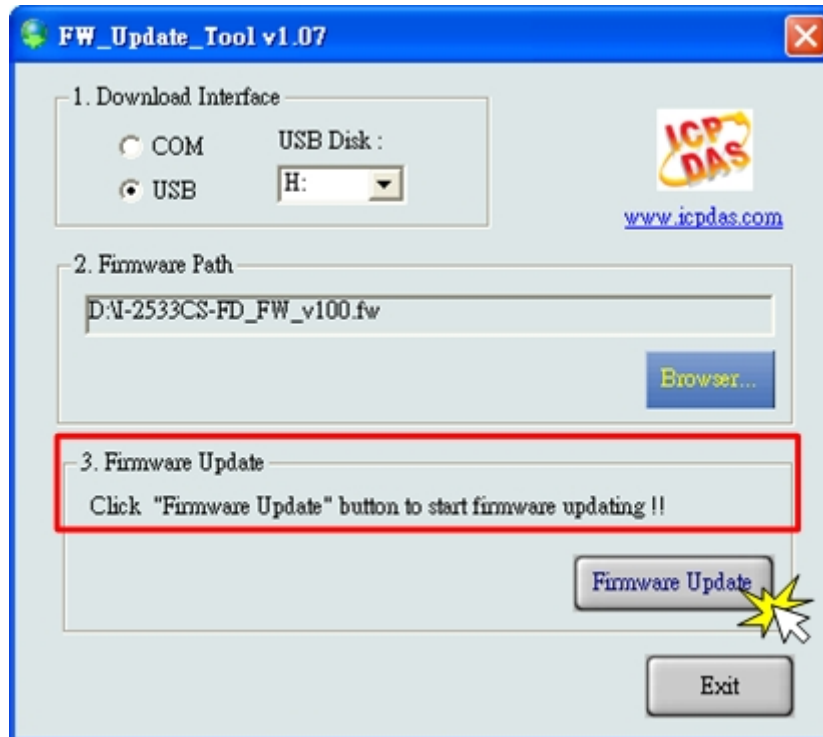

Step 11: Set the 10-pin dip switch to the necessary position and reboot the module. Then press the “Exit” button to exit.

# 6. Appendix

## 6.1. Revision History

This chapter provides revision history information to this document. The table below shows the revision history.

Revision	Date	Description
1.0.0	202/04/14	Initial issue



## 6.2. Dimension

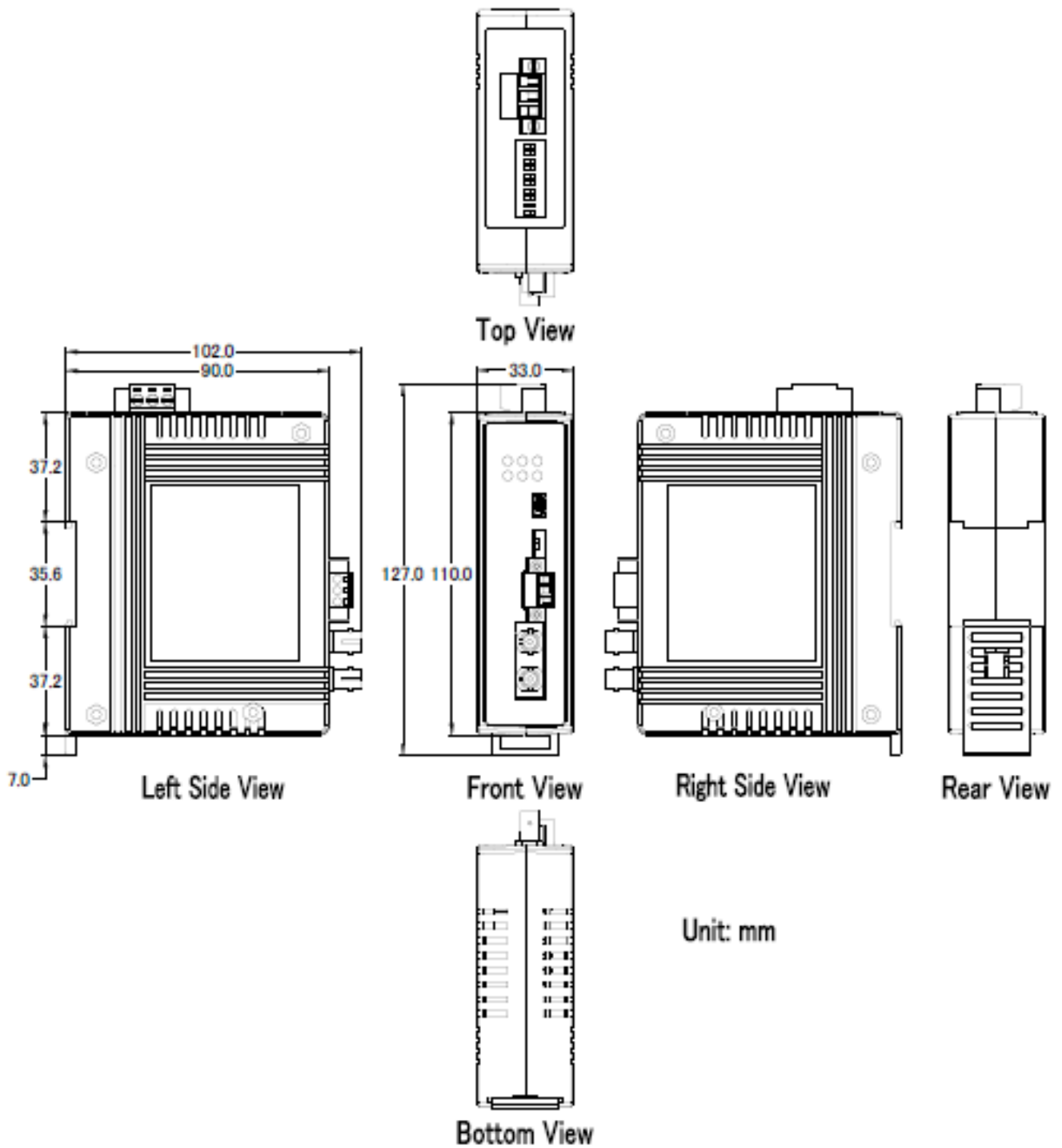

## 6.3. CAN Status Register

Bit	Symbol	Value	Description
2:0	LEC		<b>Last error code</b> These bits indicate the type of the last error to occur on the CAN bus. This bit field will be cleared when a message has been transferred without error. The bits in this bit field will be set upon a read access.
		0x0	<b>No error.</b>
		0x1	<b>Stuff error:</b> More than 5 equal bits in a sequence have occurred in a part of a received message where this is not allowed.
		0x2	<b>Form error:</b> A fixed format part of a received frame has the wrong format.
		0x3	<b>AckError:</b> The message transmitted by the M_CAN was not acknowledged by another node.
		0x4	<b>Bit1Error:</b> During the transmission of a message (with the exception of the arbitration field), the device wanted to send a recessive level (bit of logical value 1), but the monitored bus value was dominant.
		0x5	<b>Bit0Error:</b> During the transmission of a message (or acknowledge bit, or active error flag, or overload flag), the device wanted to send a dominant level (data or identifier bit logical value 0), but the monitored bus value was recessive. During Bus_Off recovery this status is set each time a sequence of 11 recessive bits has been monitored. This enables the CPU to monitor the proceeding of the Bus_Off recovery sequence (indicating the bus is not stuck at dominant or continuously disturbed).
		0x6	<b>CRCErrror:</b> The CRC check sum of a received message was incorrect. The CRC of an incoming message does not match with the CRC calculated from the received data.
		0x7	<b>Unused:</b> No CAN Bus event was detected
4:3	ACT		Activity. This register monitors the CAN communication state.
		0x0	<b>Synchronizing</b> – node is synchronizing on CAN communication.
		0x1	<b>Idle</b> – node is neither receiver nor transmitter.
		0x2	<b>Receiver</b> – node is operating as receiver
		0x3	<b>Transmitter</b> – node is operating as transmitter.
5	EP		Error passive
		0	The CAN controller is in the error active state.
		1	The CAN controller is in the error passive state as defined in the CAN 2.0 specification.
6	EW		Warning status
		0	Both error counters are below the Error_Warning limit of 96
		1	At least one of error counter has reached the Error_Warning limit of 96
7	BOFF		Busoff status
		0	The CAN module is not in busoff state.
		1	The CAN controller is in busoff state.
31:8	-	-	Reserved

## 6.4. CAN Error Counter Register

Bit	Symbol	Value	Description
7:0	TEC		Transmit error counter Current value of the transmit error counter (maximum value 255)
14:8	REC		Receive error counter Current value of the receive error counter (maximum value 127).
15	RP		Receive error passive
		0	Below error level. The receive counter is below the error passive level of 128
		1	At error level. The receive counter has reached the error passive level of 128
31:16	-	-	Reserved

## 6.5. Valid CAN FD Data Phase Bit Rat

Items	Supported CAN FD Data Phase Bit Rate (kbps)				
	0	1	2	3	4
0	10000.000	8571.429	7500.000	6666.667	6000.000
5	5454.545	5000.000	4615.385	4285.714	4000.000
10	3750.000	3529.412	3333.333	3157.895	3000.000
15	2857.143	2727.273	2608.696	2500.000	2400.000
20	2307.692	2222.222	2142.857	2068.966	2000.000
25	1935.484	1875.000	1818.182	1764.706	1714.286
30	1666.667	1621.622	1578.947	1538.462	1500.000
35	1463.415	1428.571	1395.349	1363.636	1333.333
40	1304.348	1276.596	1250.000	1224.49	1200.000
45	1176.471	1153.846	1132.075	1111.111	1090.909
50	1071.429	1052.632	1034.483	1016.949	1000.000
55	983.6066	967.7419	952.381	937.500	923.0769
60	909.0909	895.5224	882.3529	869.5652	857.1429
65	845.0704	833.3333	821.9178	810.8108	800.000
70	789.4737	779.2208	769.2308	759.4937	750.000
75	740.7407	731.7073	722.8916	714.2857	705.8824
80	697.6744	689.6552	681.8182	674.1573	666.6667
85	659.3407	652.1739	645.1613	638.2979	631.5789
90	625.000	618.5567	612.2449	606.0606	600.000
95	594.0594	588.2353	582.5243	576.9231	571.4286
100	566.0377	560.7477	555.5556	550.4587	545.4545
105	540.5405	535.7143	530.9735	526.3158	521.7391
110	517.2414	512.8205	508.4746	504.2017	500.000
115	495.8678	491.8033	487.8049	483.871	480.000
120	476.1905	472.4409	468.750	465.1163	461.5385
125	458.0153	454.5455	451.1278	447.7612	444.4444
130	441.1765	437.9562	434.7826	431.6547	428.5714
135	425.5319	422.5352	419.5804	416.6667	413.7931
140	410.9589	408.1633	405.4054	402.6846	400.000
145	397.351	394.7368	392.1569	389.6104	387.0968
150	384.6154	382.1656	379.7468	377.3585	375.000
155	372.6708	370.3704	368.0982	365.8537	363.6364
160	361.4458	359.2814	357.1429	355.0296	352.9412
165	350.8772	348.8372	346.8208	344.8276	342.8571

170	340.9091	338.9831	337.0787	335.1955	333.3333
175	331.4917	329.6703	327.8689	326.087	324.3243
180	322.5806	320.8556	319.1489	317.4603	315.7895
185	314.1361	312.500	310.8808	309.2784	307.6923
190	306.1224	304.5685	303.0303	301.5075	300.000
195	298.5075	297.0297	295.5665	294.1176	292.6829
200	291.2621	289.8551	288.4615	287.0813	285.7143
205	284.3602	283.0189	281.6901	280.3738	279.0698
210	277.7778	276.4977	275.2294	273.9726	272.7273
215	271.4932	270.2703	269.0583	267.8571	266.6667
220	265.4867	264.3172	263.1579	262.0087	260.8696
225	259.7403	258.6207	257.5107	256.4103	255.3191
230	254.2373	253.1646	252.1008	251.046	250.000
235	248.9627	247.9339	246.9136	245.9016	244.898
240	243.9024	242.915	241.9355	240.9639	240.000
245 ~ 290	...				
290	202.7027	202.0202	201.3423	200.6689	200.000
295 ~ 365	...				
365	161.7251	161.2903	160.8579	160.4278	160.000
370~390	...				
390	151.5152	151.1335	150.7538	150.3759	150.000
395~470	...				
470	126.0504	125.7862	125.523	125.261	125.000
475 ~ 490	...				
490	120.9677	120.7243	120.4819	120.2405	120.000
495 ~ 590	...				
590	100.6711	100.5025	100.3344	100.1669	100.000