

LV-67Z

Mini-ITX Mobile Motherboard

User's Manual

Edition 1.2

2020/01/08

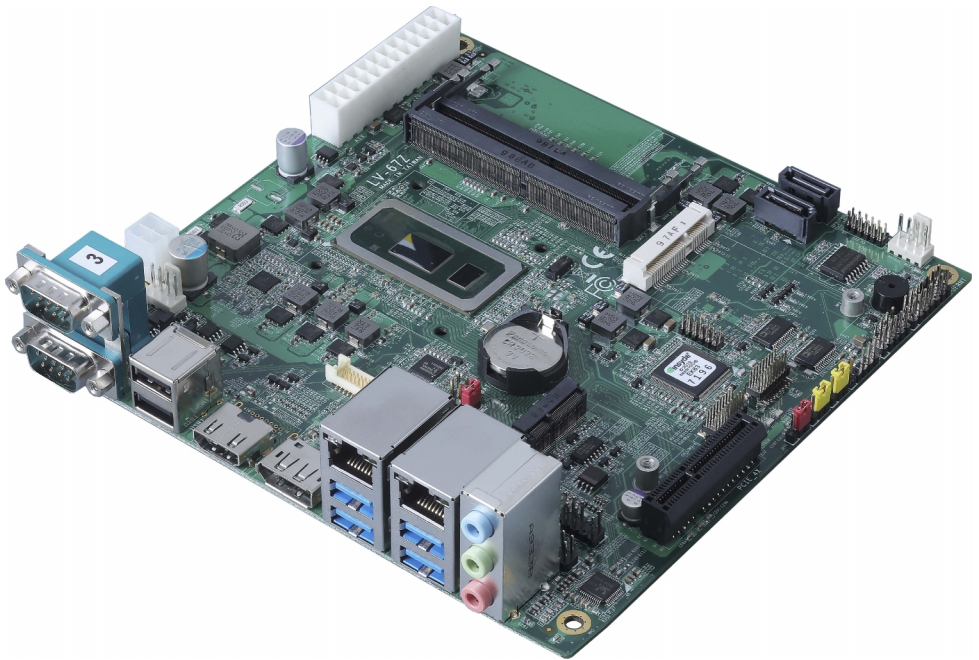

Copyright

Copyright 2019, all rights reserved. This document is copyrighted and all rights are reserved. The information in this document is subject to change without prior notice to make improvements to the products.

This document contains proprietary information and protected by copyright. No part of this document may be reproduced, copied, or translated in any form or any means without prior written permission of the manufacturer.

All trademarks and/or registered trademarks contains in this document are property of their respective owners.

Disclaimer

The company shall not be liable for any incidental or consequential damages resulting from the performance or use of this product.

The company does not issue a warranty of any kind, express or implied, including without limitation implied warranties of merchantability or fitness for a particular purpose.

The company has the right to revise the manual or include changes in the specifications of the product described within it at any time without notice and without obligation to notify any person of such revision or changes.

Trademark

All trademarks are the property of their respective holders.

Any questions please visit our website at <http://www.commell.com.tw>

Packing List:

Please check the package content before you starting using the board.



1 x LV-67Z Mini-ITX Motherboard
(include Cooler Fan)

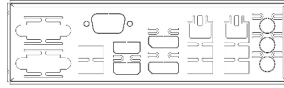

1 x I/O Shield
(OPLATE-CUHDLAT) / (1270077)



1 x DC Power Cable
(OALDC-A) / (1040433)

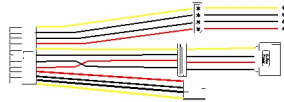

1 x Power Cable
(OALATX-P3S2 / 1040058)



2 x SATA Cable
(OALSATA3-L) / (1040529)



1 x Driver CD
(Including User's Manual)

OPTIONAL:

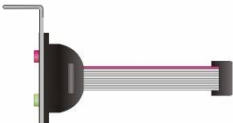

1 x Audio cable
(OALPJ-HD) / (1040120)

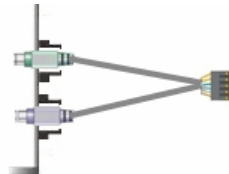

1 x PS/2 Keyboard & Mouse cable
(OALPS2/KMB) / (1040610)



1 x Dual COM PORT Cable
(OALEB-BKU2) / (1040087)

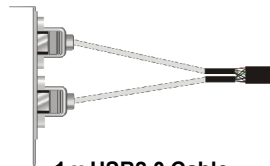

1 x USB2.0 Cable
(OALUSBA-1) / (1040172)

Index

Chapter 1 <Introduction>	4
1.1 <Product Overview>	4
1.2 <Product Specification>	5
1.3 <Block Diagram>	6
Chapter 2 <Hardware setup>	7
2.1 <Connector Location and Reference>	7
2.1.1 <Internal connectors list>	8
2.1.2 <External connectors list>	8
2.2 <Memory Setup>	9
2.3 <Jumper Location and Reference>	10
2.3.1 <Jumper list>	10
2.3.2 <Clear CMOS and Power on type selection>	11
2.4 <I/O interface>	11
2.4.1 <Serial ATA interface>	11
2.4.2 <Ethernet interface>	12
2.4.3 <Display interface>	12
2.4.4 <Serial Port interface>	14
2.4.5 <USB interface>	17
2.4.6 <Audio interface>	18
2.4.7 <Expansion slot>	19
2.4.8 <Front panel switch and indicator>	20
2.4.9 <GPIO and Other interface>	21
2.5 <Power supply>	24
2.5.1 <Power input>	24
2.5.2 <Power Output>	25
Appendix A <Flash BIOS>	26
Appendix B <LCD Panel Type select>	27
Appendix C <Programmable Watch Dog Timer>	29
Appendix D <Hardware Monitor>	31
Appendix E <Programmable GPIO>	32
Appendix F <RAID Setting>	33
Contact information	34

Chapter 1 <Introduction>

1.1 <Product Overview>

LV-67Z is Mini-ITX Motherboard which supports 8th Generation Intel® Core™ U-Series processors, integrated HD Graphics, DDR4 memory, Realtek High Definition Audio, Intel Gigabit LAN, USB3.1 Gen2, SATA3 with AHCI function for a system.

New feature for Whiskey Lake

Whiskey Lake-U processors are based on the 14nm++ process node, and offer long-life availability. They have a TDP of 15W, and integrate Gen 9.5 Intel Graphics GT2. It allows triple independent display with 4K resolution.

All in One multimedia solution

The board provides high performance onboard graphics, and supports single bus or dual bus LVDS signaling with color depths of 18 bits or 24 bits, DisplayPort, HDMI, and High Definition Audio, to meet the very requirement of the multimedia application.

Flexible Expansion Interface

The board provides one MiniPCIe slot(support mSATA), one M.2 2230 slot and PCIe x4 slot.

Whiskey Lake support Windows10 64bit RS5 and Linux

Intel recommend using Windows 10 64bit RS5. It may lose some drivers if you use other Windows version.

1.2 <Product Specification>

System

Processor	Intel® Whiskey Lake Processor FCBGA1528 package
Memory	2 x DDR4 SO-DIMM 2400 MHz up to 32GB, Support Non-ECC, unbuffered memory
Watchdog Timer	Generates a system reset with internal timer for 1min/s ~ 255min/s
Real Time Clock	Chipset integrated RTC with onboard lithium battery
Expansion	1 x MiniPCIe (support mSATA) 1 x M.2 (Key E) for Wi-Fi and Bluetooth 2230mm 1 x PCIe x4 slot

Graphics

Chipset	Intel® Gen 9.5 integrated HD Graphics
Display Interface	1 x DisplayPort, 1 x HDMI 1 x LVDS,

LAN

Chip	1 x Intel® I219-LM Gigabit PHY LAN (Support iAMT12.0) 1 x Intel® I210-AT Gigabit LAN
------	---

I/O

Serial ATA	2 x SATA3 mSATA and SATA3-2 can't not use at the same time
Audio	Realtek ALC262 HD Audio
Internal I/O	2 x SATA3, 4 x RS232, 2 x USB2.0, 1 x LVDS, 1 x LPC, 1 x LCD inverter, 1 x GPIO, 1 x Audio, 1 x PS/2, 1 x SMBUS
Rear I/O	1 x DisplayPort, 1 x HDMI, 4 x USB3.1 Gen2, 2 x USB2.0 2 x LAN, 2 x RS232/422/485, 1 x Audio.

Mechanical & Environmental

Power Requirement	Standard 24-pin ATX power supply or 4-pin 9~35V Do not use at the same time
Size & Thickness	170mm x 170mm (L x W)
Temperature	Operating within 0°C~60°C (32°F~140°F) Storage within -20°C~80°C (-4°F~176°F)
Relative Humidity	10%~90%, non-condensing

1.3 <Block Diagram>

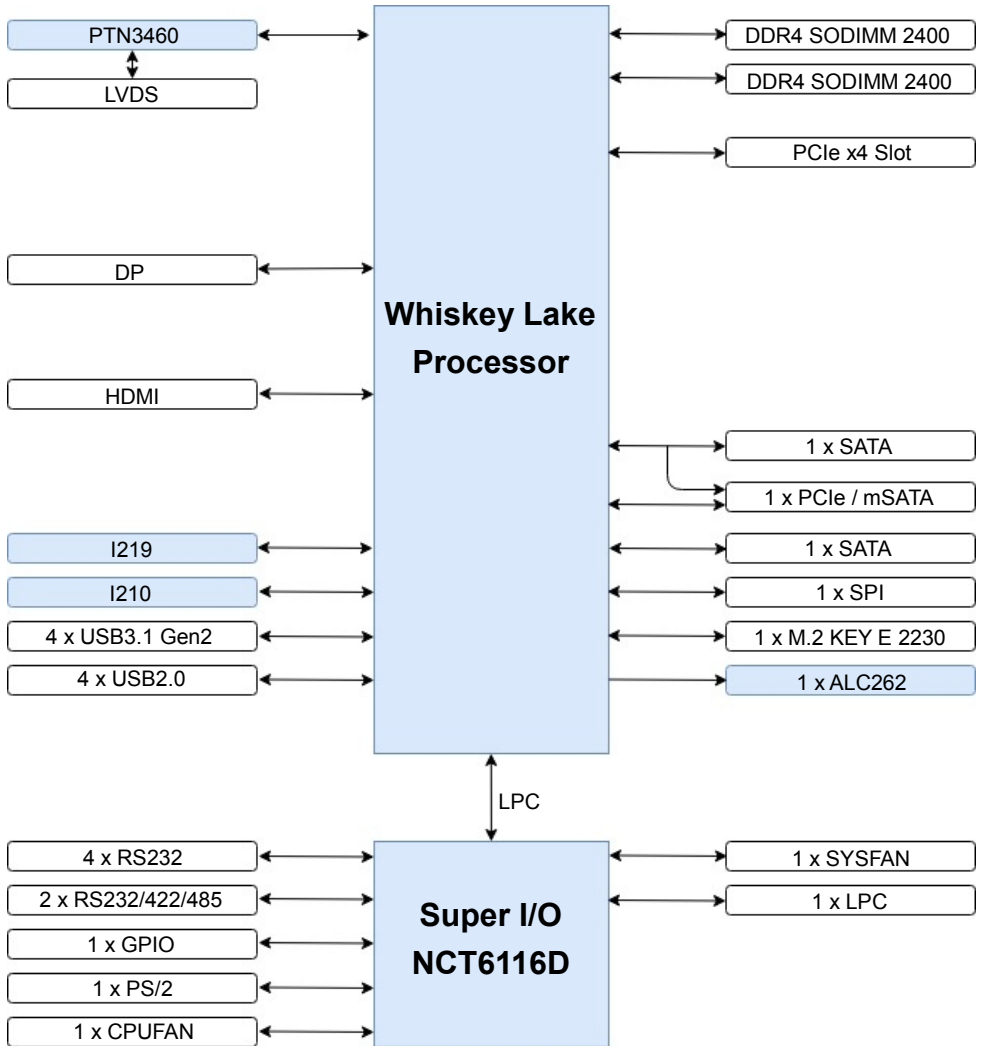

Chapter 2 <Hardware setup>

2.1 <Connector Location and Reference>

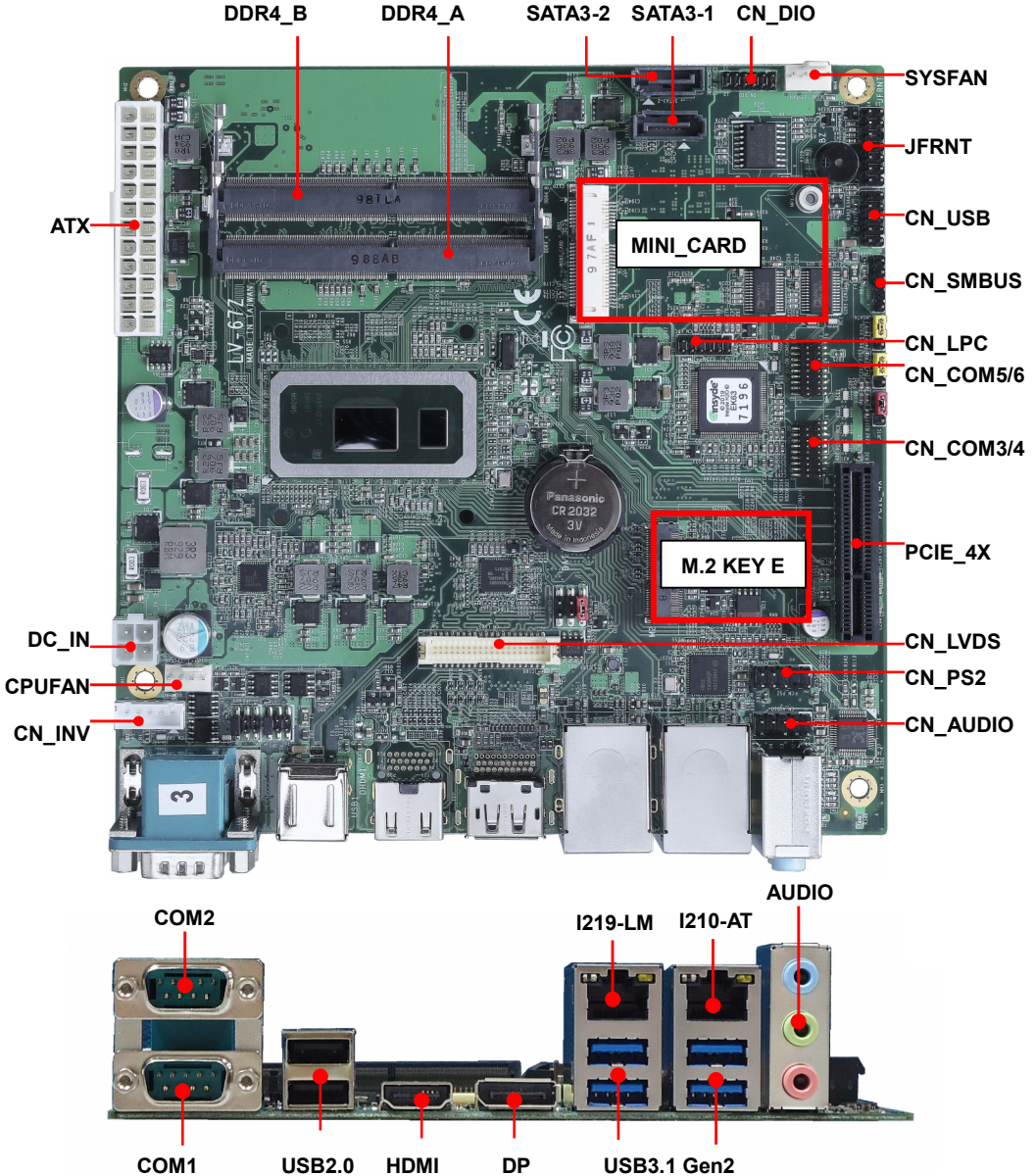

2.1.1 <Internal connectors list>

Connector	Function
DDR4_A/B	260-pin DDR4 SO-DIMM slot
SATA3-1/2	7-pin Serial ATA3 connector
CN_AUDIO	5 x 2-pin audio pin header
CN_LPC	6 x 2-pin LPC pin header
CN_LVDS	20 x 2-pin LVDS connector
CN_INV	5-pin LCD inverter connector
CN_SMBUS	5-pin SMBus connector
CN_COM 3/4/5/6	20-pin RS232 connector
CN_USB 2-1/2-2	5 x 2-pin USB2.0 pin header
CN_PS2	5 x 2-pin PS/2 pin header
CN_DIO	6 x 2-pin digital I/O connector
CPUFAN	4-pin CPU fan connector
SYSFAN	4-pin system fan connector
JFRNT	14-pin front panel switch/indicator connector
PCIE_4X	64-pin PCIE x4 slot
MINI_CARD	52-pin MiniPCle card slot (Support mSATA)
ATX	24-pin power supply connector
DC_IN	4-pin power input Terminal Block

2.1.2 <External connectors list>

Connector	Function
DDP	DisplayPort connector
DHDMI	HDMI connector
USB_RJ45_1	USB3.1 Gen2 and RJ45 connector (i219-LM)
USB_RJ45_2	USB3.1 Gen2 and RJ45 connector (i210-AT)
USB1	USB2.0 connector
AUDIO	Audio connector
COM12	DB9 Serial port connector

2.2 <Memory Setup>

In the process, the board must be powered off.

1. Put the memory tilt into the slot. Note the Memory notch key aligned slot key.
2. Then press down till lock into the mounting notch.

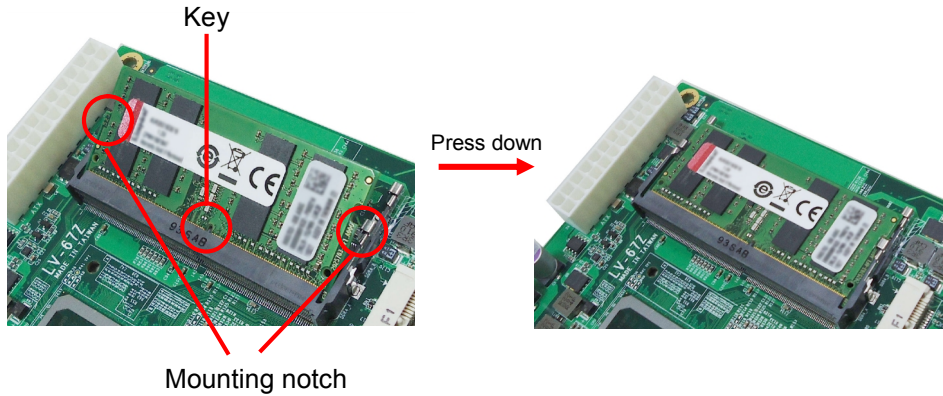

3. To remove the memory, push outward on both sides of the latch.

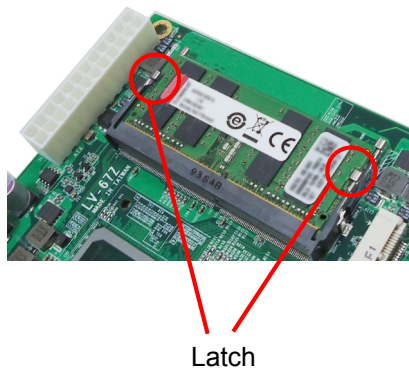

2.3 <Jumper Location and Reference>

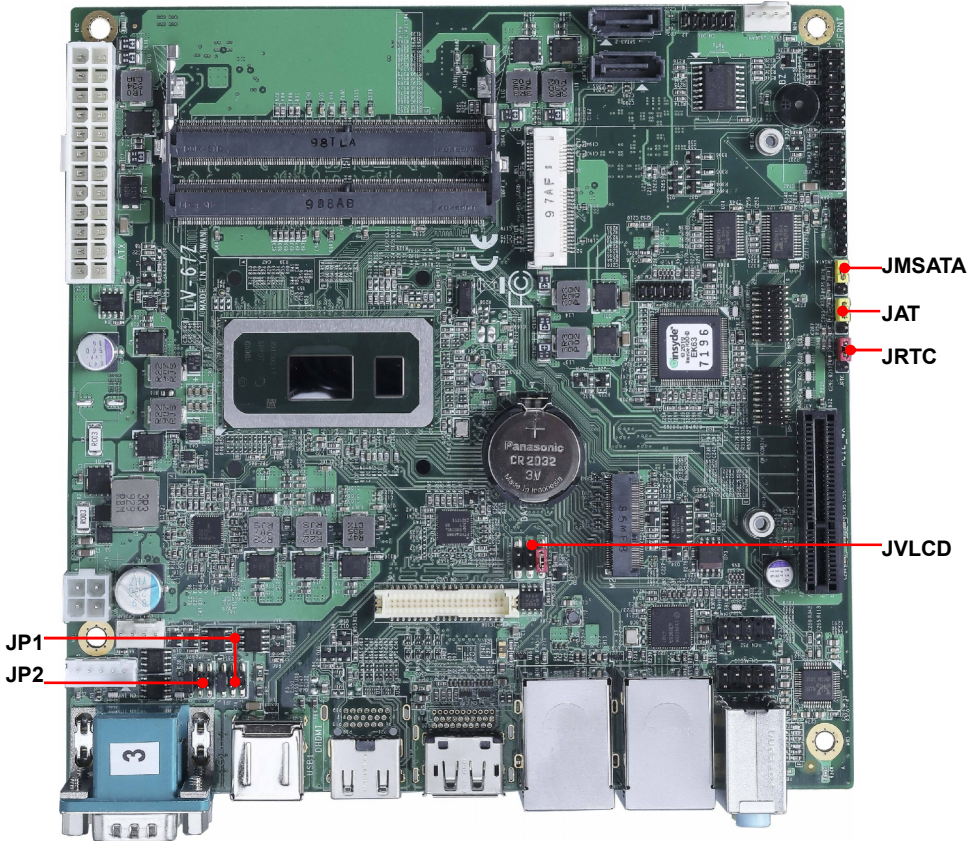

2.3.1 <Jumper list>

Jumper	Function
JAT	Power mode select
JRTC	CMOS Normal/Clear Setting
JVLCD	Panel Voltage Setting
JMSATA	MiniCard mSATA Setting
JP1	COM1 Voltage Setting (For Pin 9)
JP2	COM2 Voltage Setting (For Pin 9)

2.3.2 <Clear CMOS and Power on type selection>

The board's data of CMOS can be setting in BIOS. If the board refuses to boot due to inappropriate CMOS settings, here is how to proceed to clear (reset) the CMOS to its default values.

JAT: AT/ATX mode select jumper

Jumper settings	Function
1-2	AT mode
2-3	ATX mode (Default)

JRTC: Clear CMOS data jumper

Jumper settings	Function
1-2	Clear CMOS
2-3	Normal (Default)

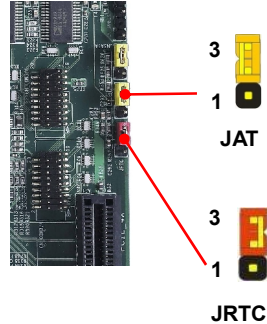

2.4 <I/O interface>

2.4.1 <Serial ATA interface>

SATA 1/2: SATA3 7-pin connector

Pin	Signal
1	GND
2	TX+
3	TX-
4	GND
5	RX-
6	RX+
7	GND

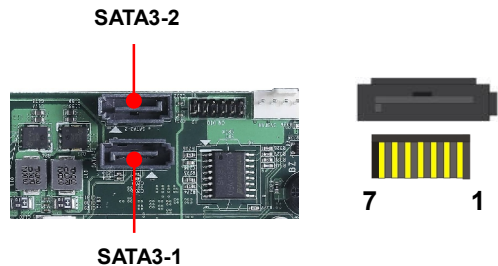

mSATA and SATA3-2 can't not use at the same time

2.4.2 <Ethernet interface>

The board provides I210-AT and I219-LM Gigabit Ethernet which supports WOL on rear I/O. It supports Intel® AMT 12.0 feature on I219-LM.

(Note that the CPU must support vPro technology.)

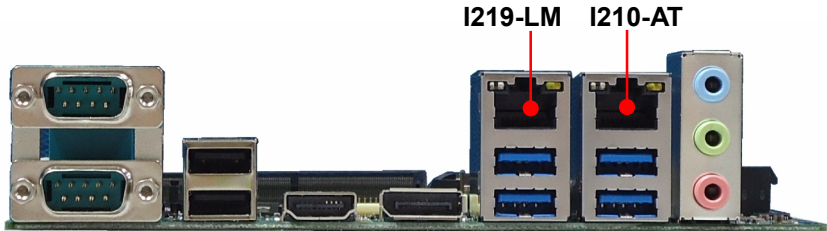

2.4.3 <Display interface>

Based on the 8th Gen CPU with built-in HD Graphics, the DisplayPort resolution up to 3840x2160 @ 60Hz or 4096x2304 @ 60Hz, the HDMI up to 4096x2304 @ 24Hz and LVDS up to 1920x1200 @ 60Hz supports single bus or dual bus LVDS signaling with color depths of 18 bits or 24 bits. About select LCD Panel Type in BIOS, please refer [Appendix B](#).

The built-in HD Graphics support triple display function with clone mode and extended mode.

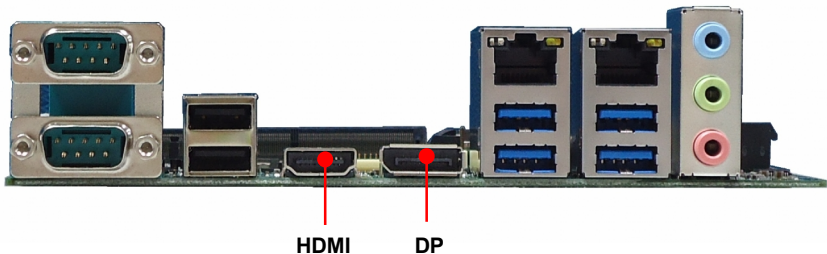

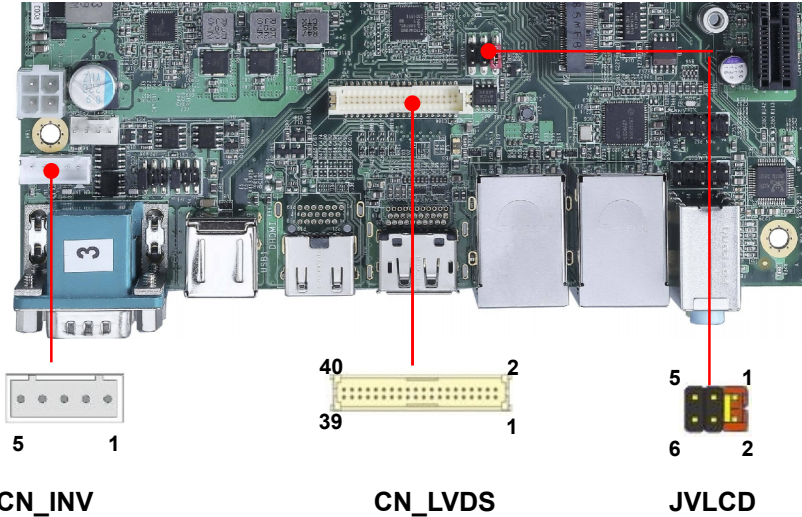

CN_LVDS: LVDS 40-pin connector (Model: HIROSE DF13-40DP-1.25V compatible)

Pin	Signal	Pin	Signal
2	Set by JVLCD	1	Set by JVLCD
4	Detect (Active low)	3	GND
6	A_LVDS_0-	5	B_LVDS_0-
8	A_LVDS_0+	7	B_LVDS_0+
10	GND	9	GND
12	A_LVDS_1-	11	B_LVDS_1-
14	A_LVDS_1+	13	B_LVDS_1+
16	GND	15	GND
18	A_LVDS_2-	17	B_LVDS_2-
20	A_LVDS_2+	19	B_LVDS_2+
22	GND	21	GND
24	A_LVDS_CLK-	23	B_LVDS_3-
26	A_LVDS_CLK+	25	B_LVDS_3+
28	GND	27	GND
30	A_LVDS_3-	29	B_LVDS_CLK-
32	A_LVDS_3+	31	B_LVDS_CLK+
34	GND	33	GND
36	LVDS_DDCSCL	35	NC
38	LVDS_DDCSDA	37	NC
40	NC	39	NC

Pin4 only need to be connected to GND

CN_INV: LVDS 5-pin Backlight power connector

Pin	Signal
1	12V
2	Backlight Control
3	GND
4	GND
5	Enable Backlight

JVLCD: LVDS panel power select jumper

Jumper settings	Function
1-2	3.3V (Default)
3-4	5V
5-6	12V

2.4.4 <Serial Port interface>

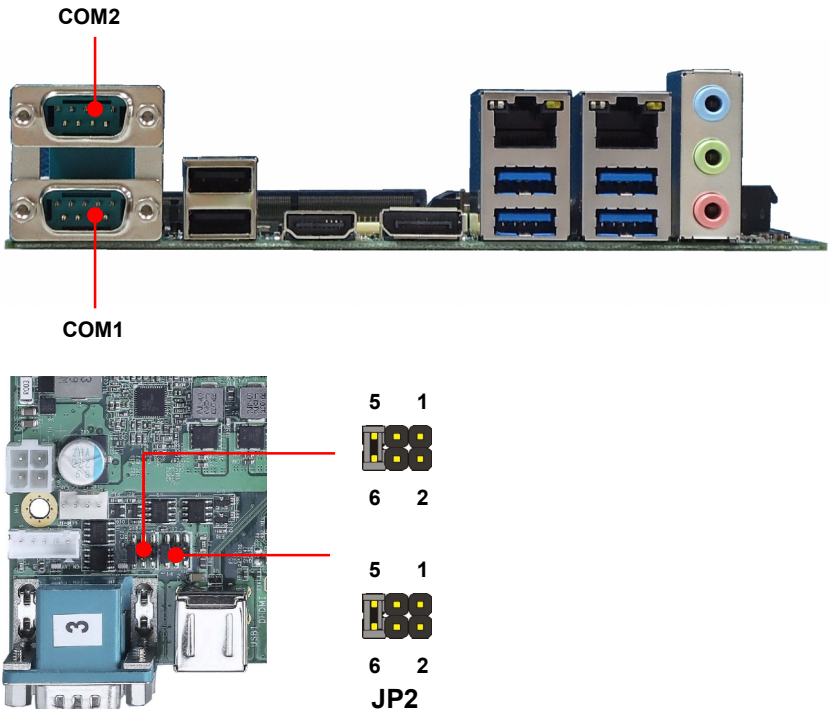

COM1: RS232/422/485 DB9 connector

Pin	Signal	Pin	Signal
1	DCD/ 422TX-/ 485-	2	RXD/ 422TX+/ 485+
3	TXD	4	DTR
5	GND	6	DSR/ 422RX+
7	RTS	8	CTS/ 422RX-
9	Set by JP1		

COM2: RS232/422/485 DB9 connector

Pin	Signal	Pin	Signal
1	DCD/ 422TX-/ 485-	2	RXD/ 422TX+/ 485+
3	TXD	4	DTR
5	GND	6	DSR/ 422RX+
7	RTS	8	CTS/ 422RX-
9	Set by JP2		

COM1 & COM2

RS-232/422/485 can set by BIOS.

You can find the setting from

On **Front Page** screen, click Setup Utility

On **Advanced** screen, click Super IO Configuration

Then click **RS232/RS422/RS485 Setting**

If you want to use RS485, please follow below step before connection. .

COM1 RTX- Data- : short Pin1& Pin8

COM1 RTX+ Data+ : short Pin2& Pin6

COM2 RTX- Data-: short Pin1& Pin8

COM2 RTX+ Data+: short Pin2& Pin6

RS232/RS422/RS485 Setting

Input/Output mode	Input	Disable
	Output	Enable RS232/RS422/RS485 Setting
GPIO Output Potential	High	RS422/RS485
	Low	RS232 (Default)

JP1, JP2: COM1, COM2 pin-9 setting

Jumper settings	Function
1-2	5V
3-4	12V
5-6	RI (Default)

Effective patterns of connection:

1-2 / 3-4 / 5-6

Other may cause damage

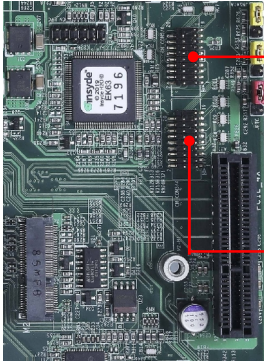
CN_COM5/6

CN_COM3/4
COM3/4: COM 20-pin header (Pitch 2.54 x 1.27mm)

Pin	Signal	Pin	Signal
1	DCD1	2	RXD1
3	TXD1	4	DTR1
5	GND	6	DSR1
7	RTS1	8	CTS1
9	RI1	10	NC
11	DCD2	12	RXD2
13	TXD2	14	DTR2
15	GND	16	DSR2
17	RTS2	18	CTS2
19	RI2	20	Key

COM5/6: COM 20-pin header (Pitch 2.54 x 1.27mm)

Pin	Signal	Pin	Signal
1	DCD1	2	RXD1
3	TXD1	4	DTR1
5	GND	6	DSR1
7	RTS1	8	CTS1
9	RI1	10	NC
11	DCD2	12	RXD2
13	TXD2	14	DTR2
15	GND	16	DSR2
17	RTS2	18	CTS2
19	RI2	20	Key

2.4.5 <USB interface>

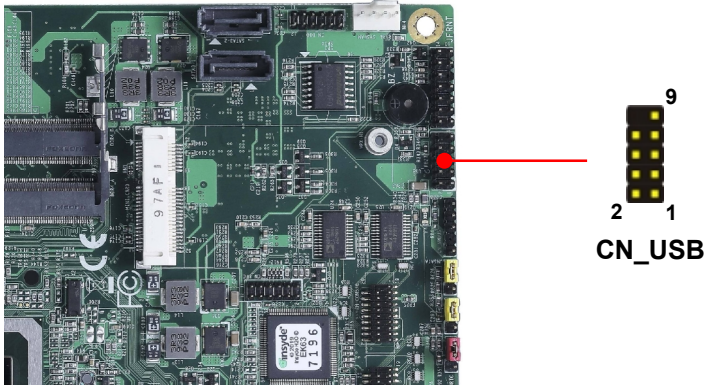
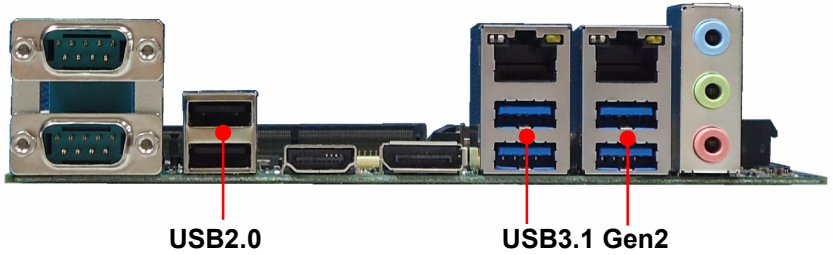

CN_USB: USB2.0 10-pin header (Pitch 2.54 mm)

Pin	Signal	Pin	Signal
1	5VSB	2	5VSB
3	DATA0-	4	DATA1-
5	DATA0+	6	DATA1+
7	GND	8	GND
9	GND	10	Key

2.4.6 <Audio interface>

Rear Audio Jack



Line in
Line out
Mic in

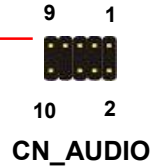
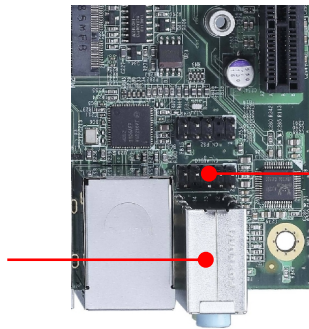

CN_AUDIO: Front panel audio 10-pin header (Pitch 2.54mm)

Pin	Signal	Pin	Signal
1	MIC_L	2	GND
3	MIC_R	4	NC
5	FP_OUT_R	6	MIC_DETECT
7	SENSE	8	Key
9	FP_OUT_L	10	FP_OUT_DETECT

2.4.7 <Expansion slot>

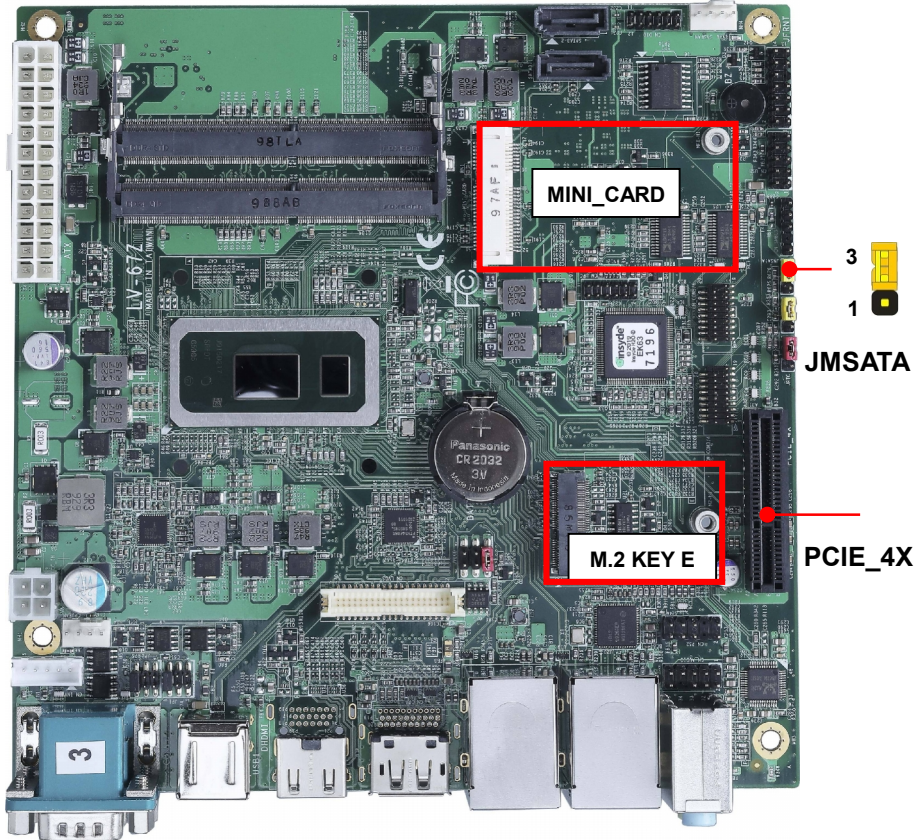

MINI_CARD have some special design to compatible our mini-PCIe card.

(ex: MPX-574D2, MPX-210D2 etc)

MINI_CARD support mSATA by JMSATA

JMSATA: Setting MINI_CARD to support PCIe/mSATA

Jumper settings	Function
1-2	Support mSATA
2-3	Normal operation (Default)

mSATA and SATA3-2 can't not use at the same time

2.4.8 <Front panel switch and indicator>

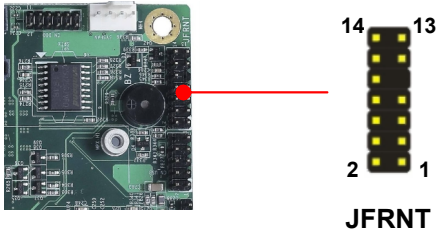

JFRNT: Front panel switch and indicator 14-pin header (Pitch 2.54mm)

Pin	Signal	Pin	Signal
1	HDD_LED+	2	Power_LED+
3	HDD_LED-	4	NC
5	Reset+	6	Power_LED-
7	Reset-	8	Speaker+
9	Key	10	NC
11	Power_ON+	12	NC
13	Power_ON-	14	Speaker-

2.4.9 <GPIO and Other interface>

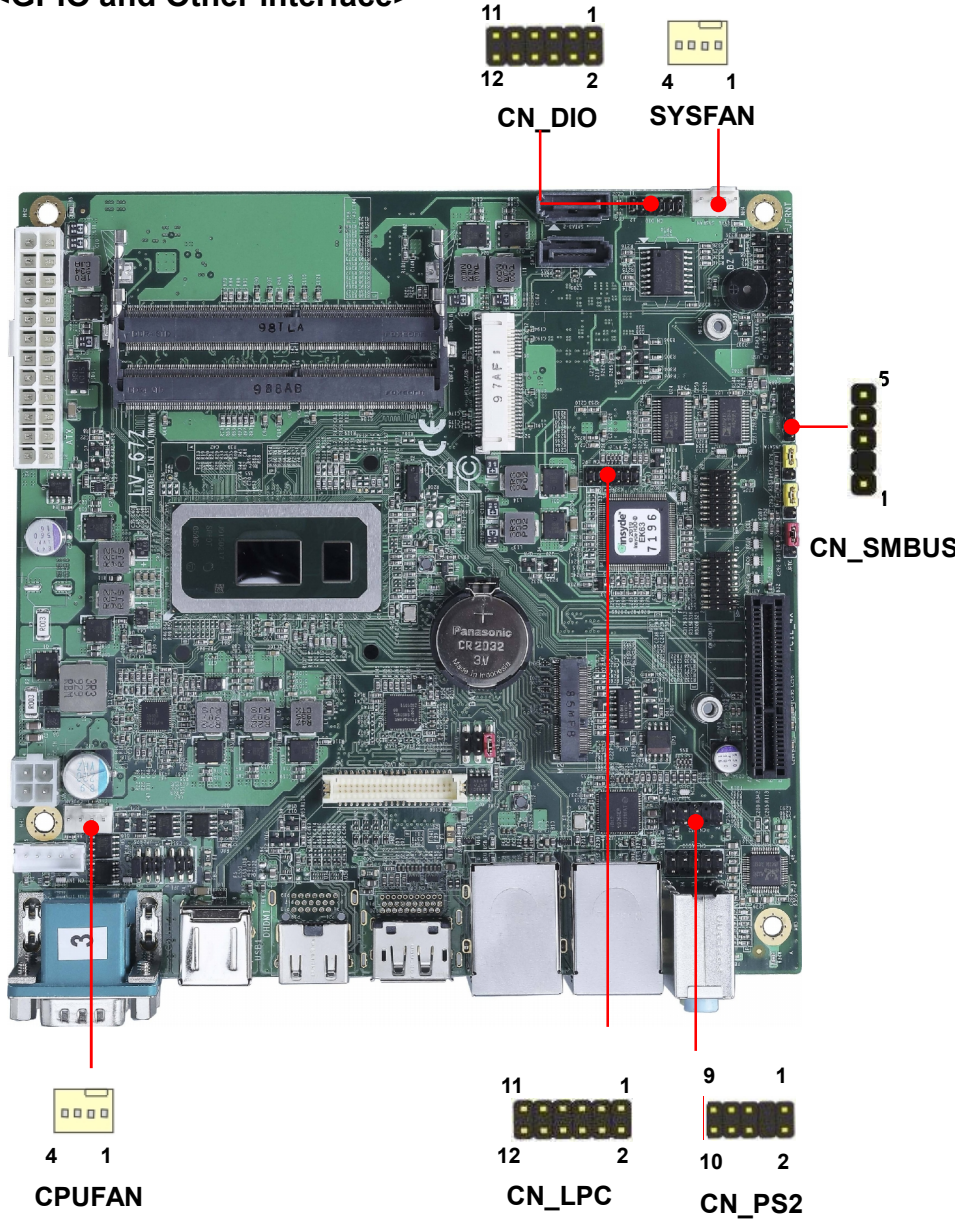

When using GPIO function

Press Delete to enter BIOS Setup menu

On **Front Page** screen, click Setup Utility

On **Advanced** screen, click Super IO Configuraion, then click GPIO 4 Configuration

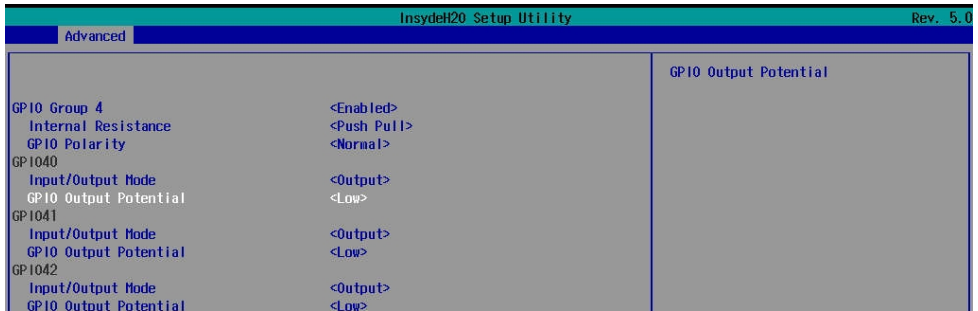

Internal Resistance: Select output type, Push pull or Open drain

Input/Output mode: Select GPIO pin mode, Input or Output

GPIO Output Potential: GPIO output value.

As Input: **TTL-level**.

GPIO DC characteristics (open drain mode)

Parameter	SYM	MIN	TYP	MAX	UNIT	Conditions
Input Low Voltage	V_{IL}			0.8	V	
Input High Voltage	V_{IH}	2.0			V	
Output Low Voltage	V_{OL}			0.4	V	$I_{OL} = 12\text{mA}$
Input High Leakage	I_{LH}			+10	μA	$V_{IN} = 3.3\text{V}$
Input Low Leakage	I_{LIL}			-10	μA	$V_{IN} = 0\text{V}$

Please refer to **Appendix E** to program the configuration register

CN_DIO: GPIO 12-pin header (Pitch 2.00mm)

Pin	Signal	Pin	Signal
1	GND	2	GND
3	GP40	4	GP44
5	GP41	6	GP45
7	GP42	8	GP46
9	GP43	10	GP47
11	5V	12	12V

CN_LPC: LPC 12-pin header (Pitch 2.00mm)

Pin	Signal	Pin	Signal
1	CLK	2	RST
3	-LFRAME	4	LAD3
5	LAD2	6	LAD1
7	LAD0	8	3.3V
9	SERIRQ	10	GND
11	3.3VSB	12	NC

CN_PS2: PS/2 10-pin header (Pitch 2.54mm)

Pin	Signal	Pin	Signal
1	KB_DATA	2	M_DATA
3	NC	4	NC
5	GND	6	GND
7	VCC	8	VCC
9	KB_CLK	10	M_CLK

CN_SMBUS: SMBus 5-pin connector (Pitch 2.54mm)

Pin	1	2	3	4	5
Signal	5V	NC	SMBDAT	SMBCLK	GND

CPUFAN: CPU cooler fan 4-pin connector

Pin	1	2	3	4
Signal	GND	12V	Sensor	Control

SYSFAN: System cooler fan 4-pin connector

Pin	1	2	3	4
Signal	GND	12V	Sensor	Control

2.5 <Power supply>

2.5.1 <Power input>

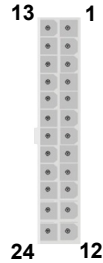
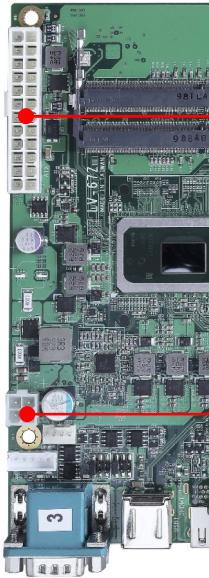

ATX



DC_IN

DC_IN: 4-pin 9~35V connector

Pin	Signal	Pin	Signal
1	GND	2	GND
3	9~35V	4	9~35V

ATX: main power 24-pin connector (**DC_IN and ATX can't use at the same time**)

Pin	Signal	Pin	Signal
1	3.3V	13	3.3V
2	3.3V	14	NC
3	GND	15	GND
4	5V	16	-PSON
5	GND	17	GND
6	5V	18	GND
7	GND	19	GND
8	Power_OK	20	NC
9	5VSB	21	5V
10	12V	22	5V
11	12V	23	5V
12	3.3V	24	GND

2.5.2 <Power Output>

It is supply to the HDD, CD-ROM or other device.

If using DC_IN as input, that ATX will be the output.

ATX: main power 24-pin connector (As output)

Pin	Signal	Pin	Signal
1	3.3V	13	3.3V
2	3.3V	14	
3	GND	15	GND
4	5V	16	
5	GND	17	GND
6	5V	18	GND
7	GND	19	GND
8		20	
9		21	5V
10	12V	22	5V
11	12V	23	5V
12	3.3V	24	GND

Appendix A <Flash BIOS>

A.1 <Flash tool>

The board is based on Insyde BIOS and can be updated easily by the BIOS auto flash tool. You can download the tool online at the address below:

[FPT Tool](#)

The tool's file name is "FPT.exe", it's the utility that can write the data into the BIOS flash chip and update the BIOS.

A.2 <Flash BIOS process>

1. Press Del to Enter BIOS Menu
2. On Front Page screen, click Setup Utility
3. On Advanced screen, click PCH-IO Configuration, then click Security Configuration
4. Set BIOS Lock to [Disabled], then save changes.

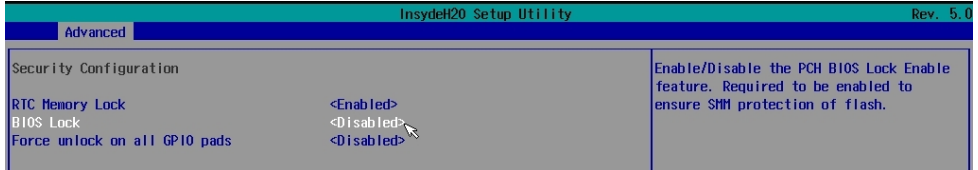

5. Please make a boot-able Disk which could boot into DOS environment.
6. Un-zip attached files and copies it into boot-able Disk.
7. Power on the system and flash the BIOS under the DOS environment.

The instruction will be "C:/fpt_-savemac_-f_XXXX.BIN"

Note: a. Underscore means Space

b. xxxx.bin means the BIOS file that you want to update

8. Please turn off the system and clean CMOS by Jumper.
9. Turn on the system and update BIOS successful.

Appendix B <LCD Panel Type select>

According to your panel, it needs to select the correct resolution in the BIOS. If there is no fit for your panel type, please feedback for us to make an OEM model.

Find the setting from

Front Page-> Setup Utility

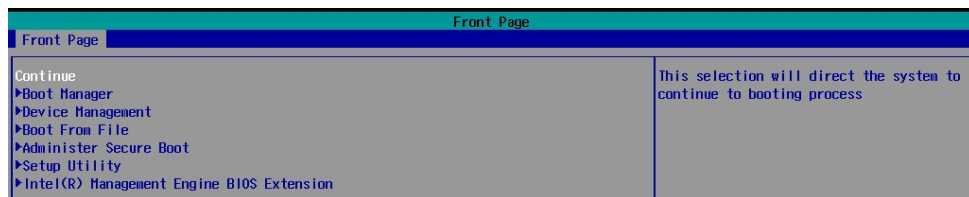

Advanced→ LVDS Configuration



Set 18bit /24bit, Single /Dual channel in LVDS configuration

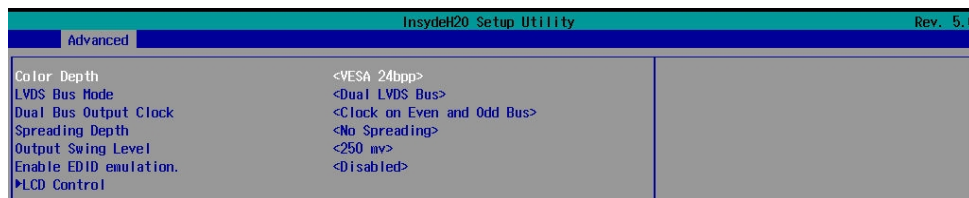

LVDS configuration → LCD Control

There are 16 resolutions in LCD Panel Type. (For Dual boot and Legacy boot)

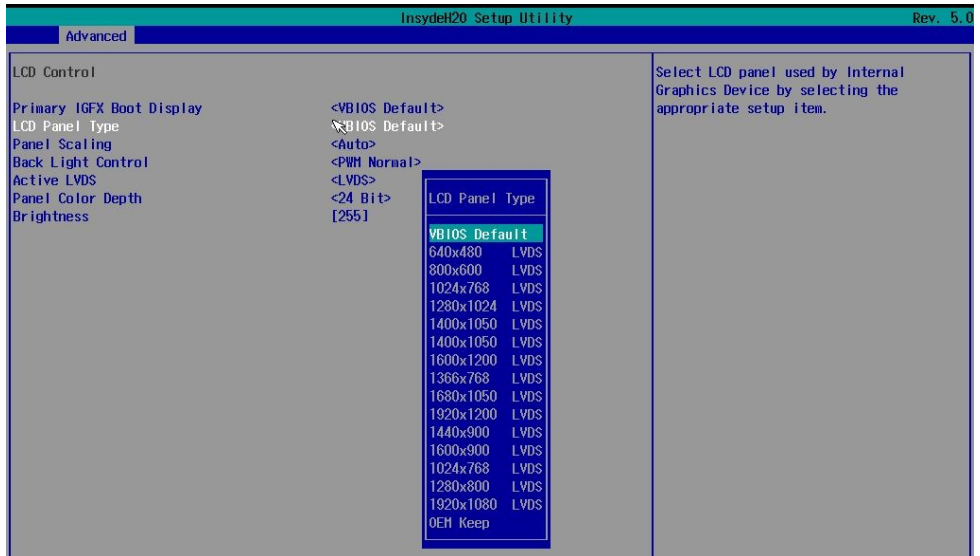
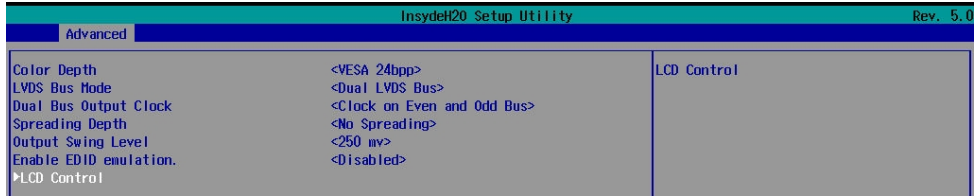

Appendix C <Programmable Watch Dog Timer>

The watchdog timer makes the system auto-reset while it stops to work for a period. The integrated watchdog timer can be setup as system reset mode by program. You can select Timer setting in the BIOS, after setting the time options, the system will reset according to the period of your selection.

Find the setting from

Advanced→Super IO Configuration

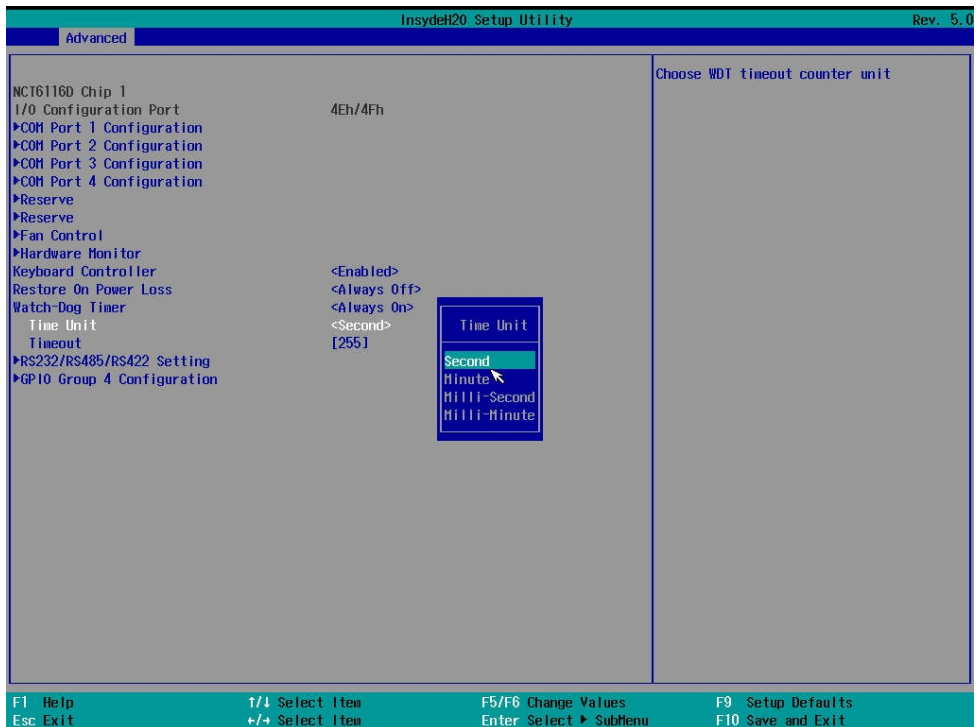

Timeout value range

1 to 255 Minute and Second

Program sample

Watchdog timer setup as system reset with 5 second of timeout

```
-o 4E 87      ;enter configuration
-o 4E 87
-o 4E 07
-o 4F 08      ;select Logical Device
-o 4E 30
-o 4F 01      ; activate WDTO# function
-o 4E F0
-o 4F 00      ;set "00" is second mode, set "08" is minute mode
-o 4E F1
-o 4F 05      ;00h: Timeout Disable
                ;01h: Timeout occurs after 1 minute only
                ;02h: Timeout occurs after 2 second/minute
                ;03h: Timeout occurs after 3 second/minute
                ;
                ;FFh: Timeout occurs after 255 second/minute
                (The deviation is approx 1 second.)
```

For further information, please refer to Nuvoton NCT6116D datasheet

Appendix D <Hardware Monitor>

Find the setting from

Advanced → Super IO Configuration → Hardware Monitor

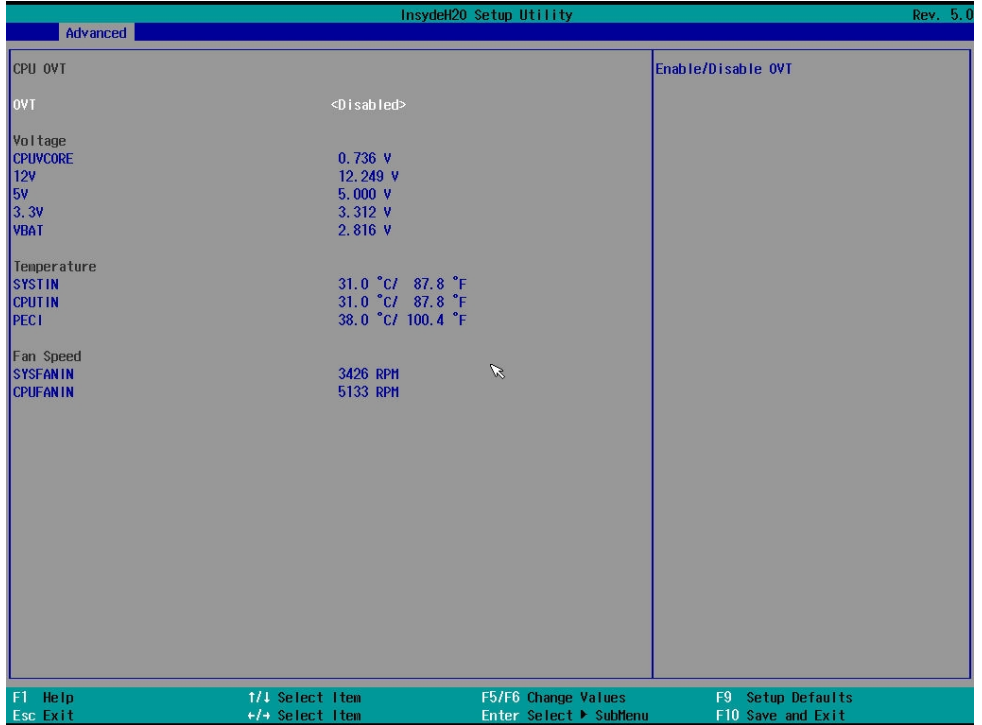

InsydeH20 Setup Utility		Rev. 5.0
Advanced		
CPU OVT		Enable/Disable OVT
OVT	<Disabled>	
Voltage		
CPUV CORE	0.736 V	
12V	12.249 V	
5V	5.000 V	
3.3V	3.312 V	
VBAT	2.816 V	
Temperature		
SYSTEM	31.0 °C/ 87.8 °F	
CPU	31.0 °C/ 87.8 °F	
PCH	38.0 °C/ 100.4 °F	
Fan Speed		
SYSFAN IN	3426 RPM	
CPUFAN IN	5133 RPM	

F1 Help ↑/↓ Select Item F5/F6 Change Values F9 Setup Defaults
 Esc Exit ←/→ Select Item Enter Select ▸ Submenu F10 Save and Exit

Appendix E <Programmable GPIO>

The GPIO can be programmed with the MS-DOS debug program using simple IN/OUT commands.

GPIO	0	1	2	3	4	5	6	7
bit	0	1	2	3	4	5	6	7

- o 4E 87 ;enter configuration
- o 4E 87
- o 4E 07
- o 4F 07 ;select Logical Device
- o 4E 30
- o 4F 10 ;activate GPIO function (The board use GPIO4)
- o 4E F0
- o 4F XX ;set "01" GPIO as input, set "00" GPIO as output
- o 4E F1
- o 4F XX ;if set GPIO as output, this register's value can be set "00~ FF"

Optional

- o 4E F2
- o 4F XX ;set "01", the respective bit are inverted (Both input and output)
;set "00", the respective bit are normal

For further information, please refer to Nuvoton NCT6116D datasheet

Appendix F <RAID Setting>

When use RAID function, it need to enter the BIOS set RAID mode first.

Advanced → PCH-IO Configuration → SATA and RST Configuration

→ SATA Mode Selection



At boot time, press <CTRL + I> to enter the RAID configuration menu.



Contact information

Any advice or comment about our products and service, or anything we can help you please don't hesitate to contact with us. We will do our best to support you for your products, projects and business.

Taiwan Commate computer Inc.

Address	19F., NO.94, Sec. 1, Xintai 5 th Rd., Xizhi Dist., New Taipei City 22102, Taiwan.
TEL	+886-2-26963909
FAX	+886-2-26963911
Website	www.commell.com.tw
E-mail	info@commell.com.tw (General information) tech@commell.com.tw (Technical Support)

Commell is a brand name of Taiwan Commate computer Inc.