Quick Start Guide for I-7188XA

July 2012, Version 1.0

Congratulations!

Congratulations on purchasing I-7188XA. This Quick Start Guide will provide information needed to get started. Please also consult the User Manual for detailed information on the setup and use of I-7188XA.

What's In the Box?

In addition to this guide, the package includes the following items:



I-7188XA



Software Utility CD



**RS-232 Cable
(CA-0910)**



**Screw
(1C016)**

Technical Support

- **7188XA_Manual_English.pdf/7188XA_Manual_Chinese.pdf**
CD:\Napdos\7188XABC\7188XA\Document
<http://ftp.icpdas.com/pub/cd/8000cd/napdos/7188xabc/7188xa/document/>
- **I-7188XA Website**
http://www.icpdas.com/products/PAC/i-7188_7186/i-7188xa.htm
- **ICP DAS Website**
<http://www.icpdas.com/>

1

Software Installation

Step 1: Insert the companion CD into the CD drive.

Step 2: Copy the 7188XA folder from **CD:\Napdos\7188XABC** to the Hard Drive of the Host PC.

Step 3: Install the MiniOS7 Utility.

Locate and execute the **minios7_utility_vXXX.exe** file from CD:\NAPDOS\MINIOS7\UTILITY\MiniOS7_utility\ folder or http://ftp.icpdas.com/pub/cd/8000cd/napdos/minios7/utility/minios7_utility/

Step 4: Copy the **7188xw.exe** file from the CD:\Napdos\MiniOS7\utility\ folder to the PATH directory, for example **C:\Windows**.

After all the software is copied to the Host PC, the content of 7188XA folder should be as follows:

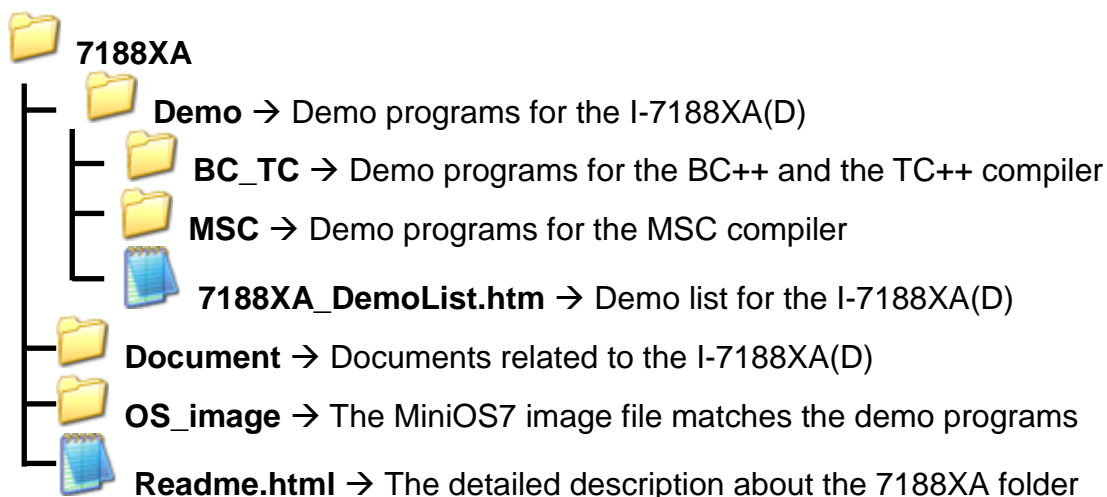

Note: The 7188xw.exe file is used as a bridge between the I-7188XA(D) and the Host PC. Therefore, the 7188xw.exe file must be copied to the “C:\Windows\” folder to allow it to be executed from any location.

2

Connecting the Download Cable to the Host PC

Step 1: Connect the CA0910 download cable between COM4 of the I-7188XA(D) and the COM Port of the Host PC, as shown in the diagram below.

Step 2: Apply power (Vs+, GND) to the I-7188XA(D). Vs+ can be in a range from +10V to +30V DC.

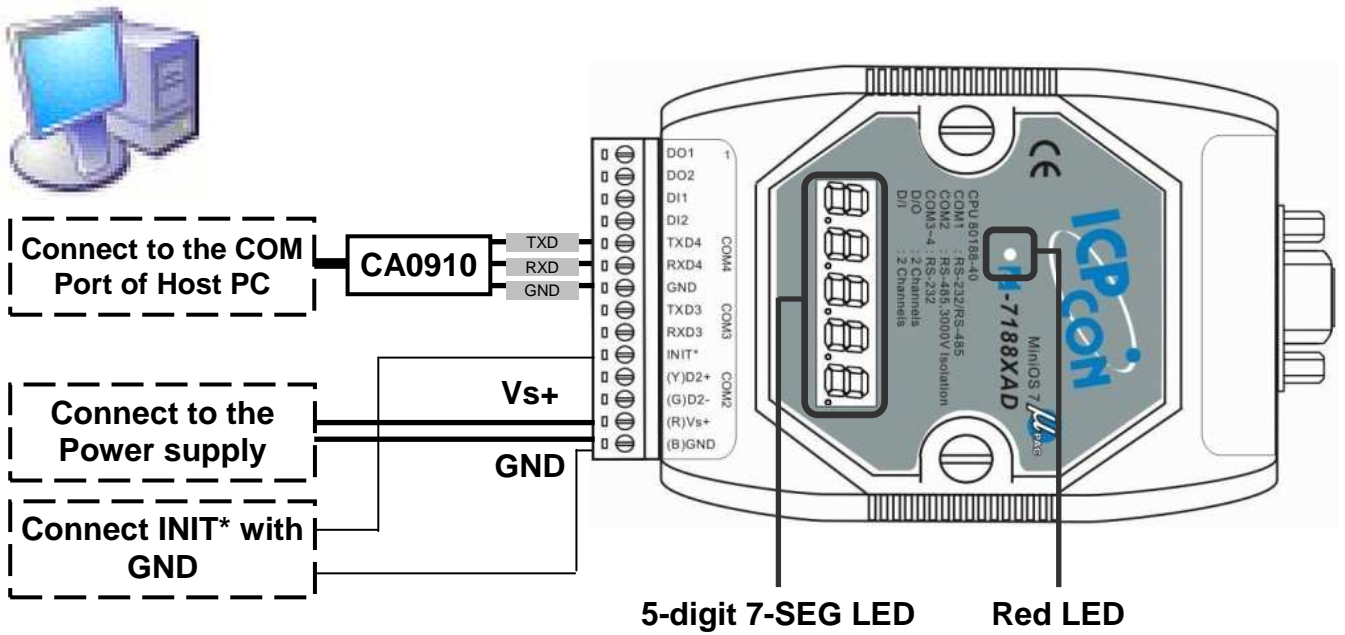

Step 3: After applying the power, the 5-digits of the 7-SEG LED will continuously show as follows.

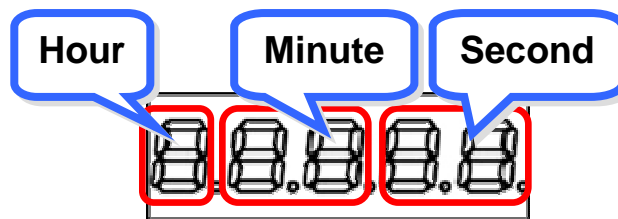

If the non-display version of module is being used, please continue to the next step.

Step 4: Check that the red LED continuously blinks four times and wait for one second to next cycle. The diagram show as follows:

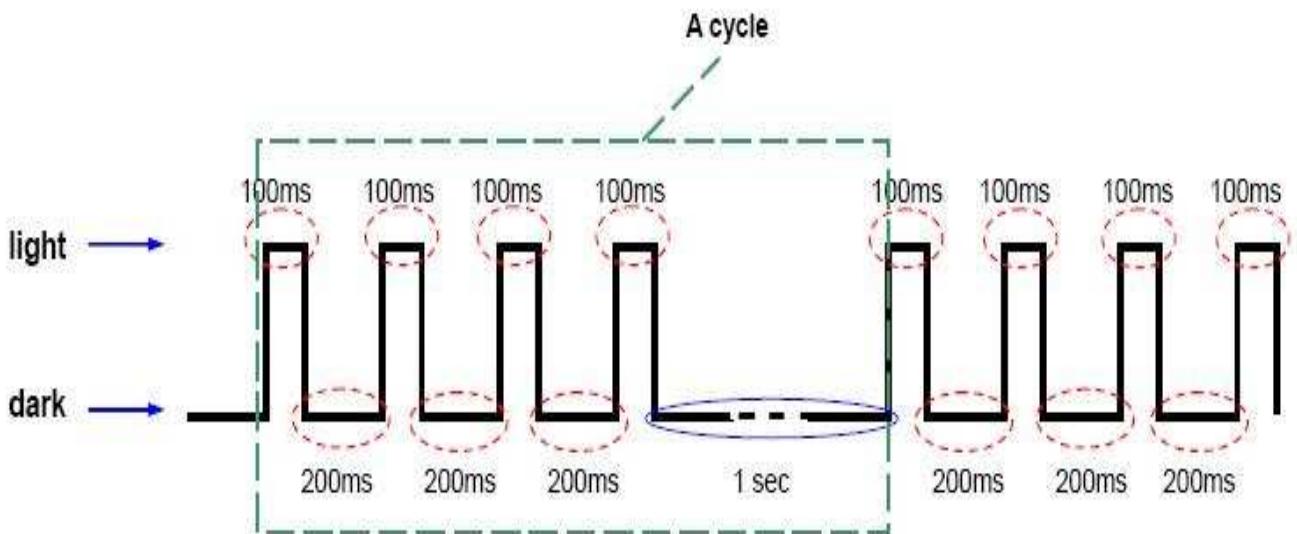

Note: Only the display version of the module will include a 5-digit 7-SEG LED.

3 Downloading Programs to the I-7188XA(D)

Before using the MiniOS7 Utility, ensure that the download cable is connected from the Host PC to the I-7188XA(D) and ensure that no other programs are running on the I-7188XA(D).



The program download procedure is as follows:

Step 1: From the Windows START menu, go to Programs/ICPDAS/MiniOS7 Utility Ver XXX/and locate the **MiniOS7 Utility Ver XXX**.

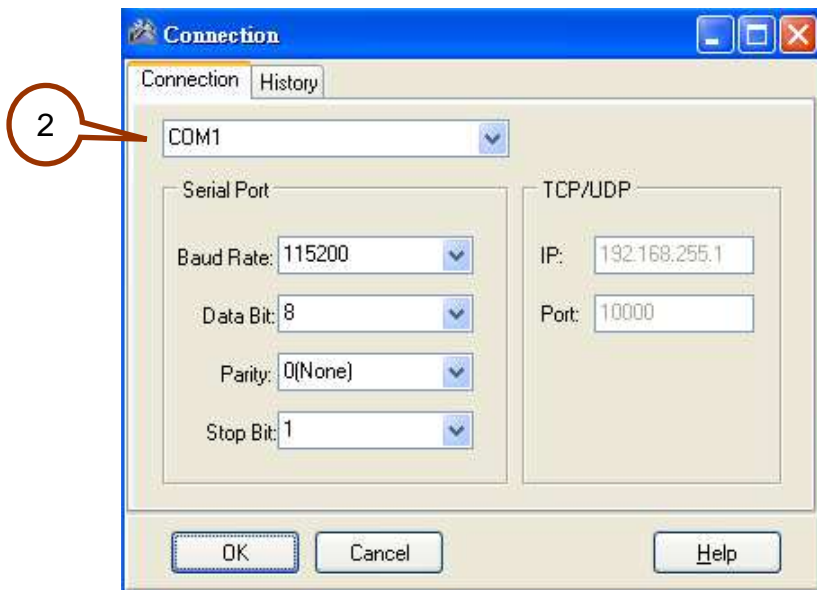
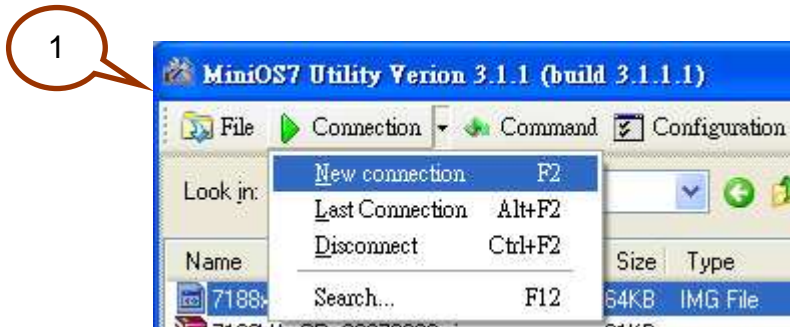

Step 2: Press  and Select "New connection". Choose the right COM port and set other parameters. Click **OK** button and the utility will search module automatically.



Step 3: See if the MiniOS7 Utility connects with I-7188XA. The connected icon is . The disconnected icon is .

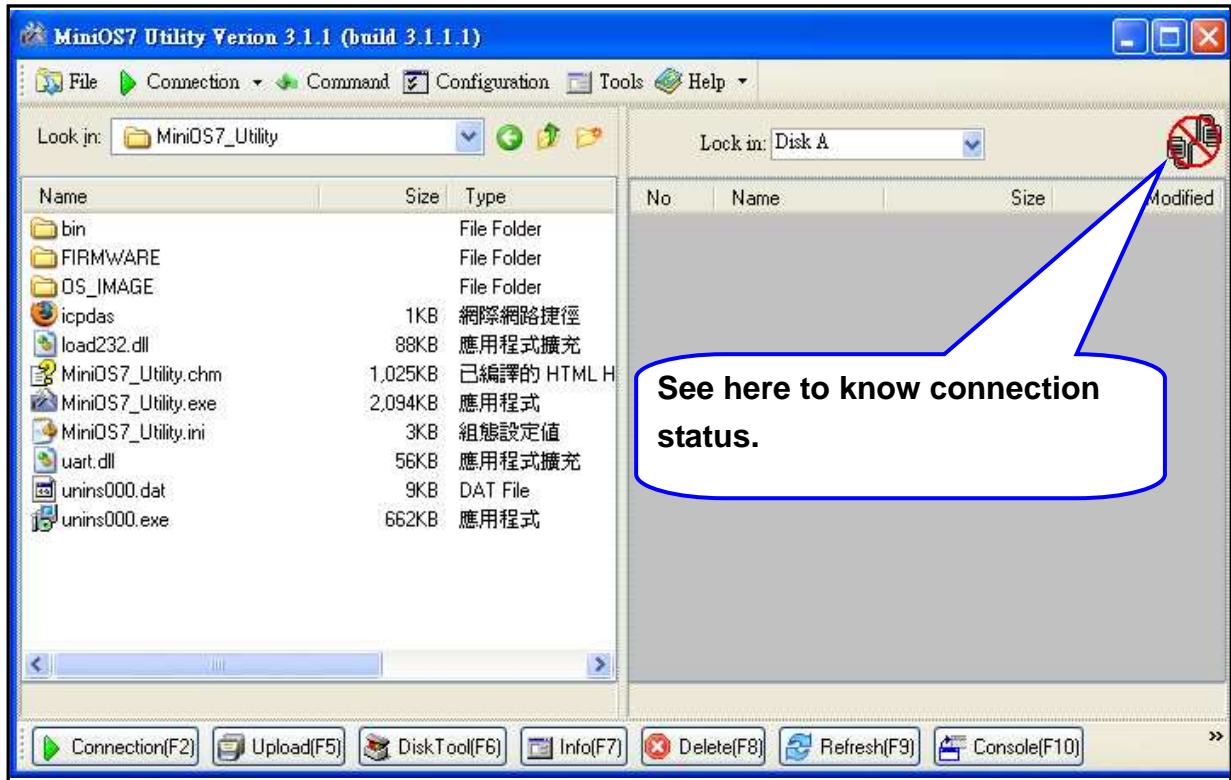

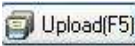
Step 4: Select the file to load from left side and click  to load file into module or draw the file to the right side.

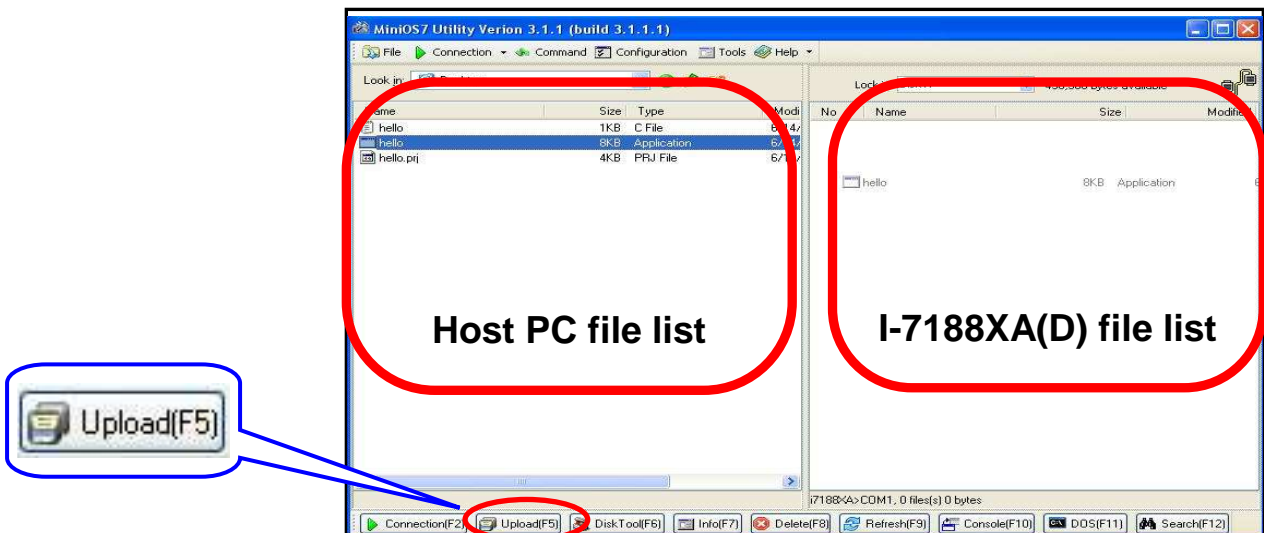

Step 5: Select the file and then press the right mouse button. Choose the **Run** and press to execute the program.

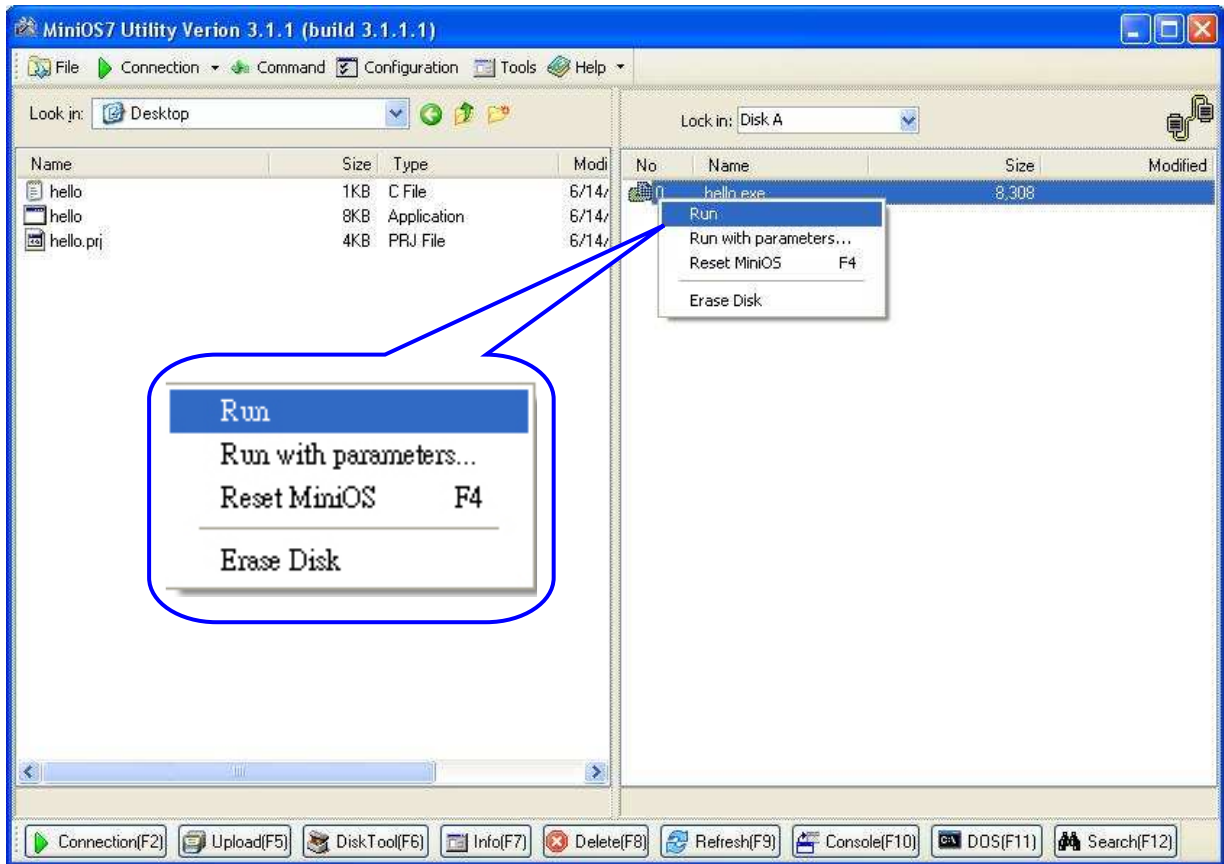

Step 6: The result of the program will be shown in 7188xw window.

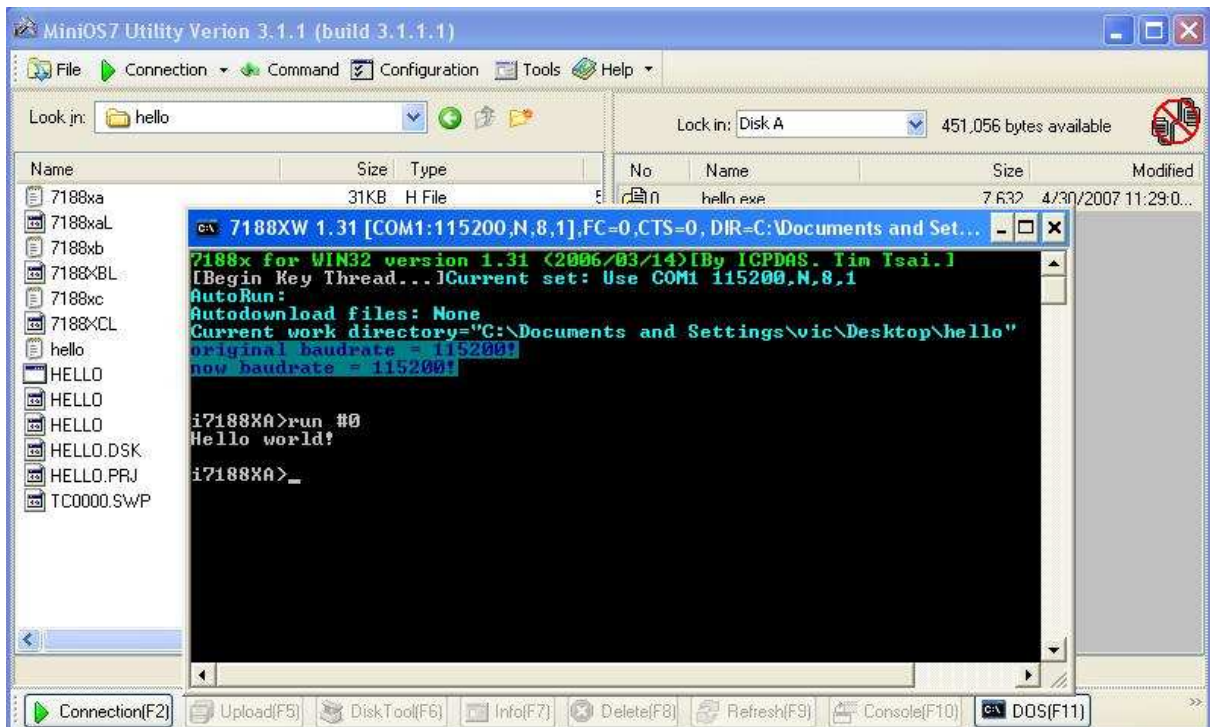

NOTE: The 7188xw window has to be closed and then the download operation (Step 4) could be done.

The content of the Hello.c file is as follow:

```
#include "7188xa.h"      /* Include the headers to use 7188xa.lib  
                        functions */  
  
void main(void)  
{  
    InitLib();           /* Initiate the 7188xa library */  
  
    Print("Hello world!\r\n"); /* Print the message on the screen */  
    ,
```